

ARV INNOVATION INTEL FOR IMPACT REPORT 2023

WP9 BUSINESS MODELS, FINANCIAL INSTRUMENTS, POLICY, AND EXPLOITATION

Jannika Aalto, Sladjana Lazarevic, Jesus Daniel Garcia Melo, Pietro Visetti, Ruth Woods, Judith Thomsen, Caroline Cheng, Nicola Lolli, Harald Taxt Walnum, Claudia Moscoso, Steinar Grynning, Guido Callegari, Alessandra Insana, Marcello Curci, Rossano Albatici, Bodil Motzke, Daniel Amin Haddadi, Robert Wawerka, Nicol Staňková, Martin Wolf, Torben Esbensen, Anne Branderup, Jan-Eric Thorsen, Marta Nicolau, Antoni Llabres Payeras, Jaume Salom, David Mayol Laverde

31.12.2023

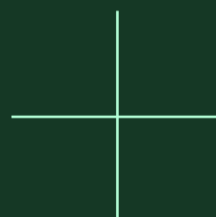
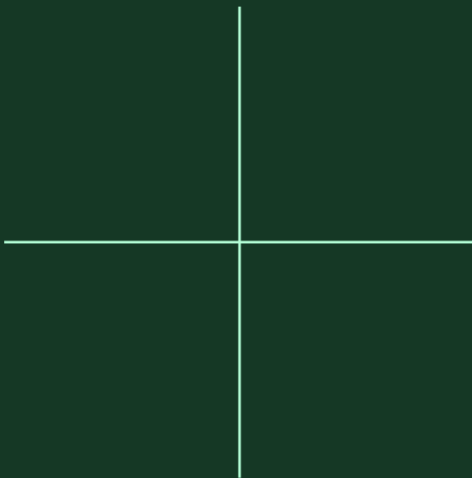

PROJECT INFORMATION

Project acronym	ARV ¹
Project title	Climate Positive Circular Communities
Project number	101036723
Coordinator	Norwegian University of Science and Technology / Inger Andresen
Website	www.GreenDeal-ARV.eu

DOCUMENT INFORMATION

Deliverable Number and Title	D.9.1 Develop an annual ARV Innovation Intel for Impact report
Due Month	Month 24 (December 2023)
Work Package Number and Title	WP9 Business models, financial instruments, policy and exploitation
Task number and Title	Task 9.1 Climate Positive Circular Communities Innovation Forum.
Dissemination Level	PU = Public, fully open
Date of Delivery	31.12.2023
Lead Author	Jannika Aalto, Pietro Visetti, Green Digital Finance Alliance (GDFA)
Contributors	Sladjana Lazarevic, Jesus Daniel Garcia Melo, Ruth Woods (NTNU), Judith Thomsen, Caroline Cheng, Nicola Lolli, Harald Taxt Walnum, Claudia Moscoso, Steinar Grynning (SINTEF), Guido Callegari, Alessandra Insana (POLITO), Marcello Curci (DTTN), Rossano Albatici (UNITN), Bodil Motzke, Daniel Amin Haddadi (OBF), Robert Wawerka, Nicol Staňková, Martin Wolf (CVUT), Torben Esbensen, Anne Branderup (PZ), Jan-Eric Thorsen (DANFOSS A S), Marta Nicolau, Antoni Llabres Payeras (PALMA), Jaume Salom (IREC), David Mayol Laverde (IBAVI)
Reviewers	Inger Andresen, NTNU
Status	Version 1.2 – 2023 annual update.

¹ ARV is a Norwegian word meaning “heritage” or “legacy”. It reflects the emphasis on circularity, a key aspect in reaching the project’s main goal of boosting the building renovation rate in Europe.

Revision Log

Version	Author	Main changes	Date
V.01	Pietro Visetti	First draft	10.12.2022
V0.2	Inger Andresen	Minor edits	28.12.2022
V1.1.	Jannika Aalto	Second version	07.12.2023
V1.2	Inger Andresen	Review – minor edits	20.12.2023

ABOUT THE ARV PROJECT

The vision of the ARV project is to contribute to speedy and wide scale implementation of Climate Positive Circular Communities (CPCC) where people can thrive and prosper for generations to come. The overall aim is to demonstrate and validate attractive, resilient, and affordable solutions for CPCC that will significantly speed up the deep energy renovations and the deployment of energy and climate measures in the construction and energy industries. To achieve this, the ARV project will employ a novel concept relying on a combination of 3 conceptual pillars, 6 demonstration projects, and 9 thematic focus areas.

The 3 conceptual pillars are integration, circularity, and simplicity. **Integration** in ARV means the coupling of people, buildings, and energy systems, through multi-stakeholder co-creation and use of innovative digital tools. **Circularity** in ARV means a systematic way of addressing circular economy through integrated use of Life Cycle Assessment, digital logbooks, and material banks. **Simplicity** in ARV means to make the solutions easy to understand and use for all stakeholders, from manufacturers to end-users.

The 6 demonstration projects are urban regeneration projects in 6 locations around Europe. They have been carefully selected to represent the different European climates and contexts, and due to their high ambitions in environmental, social, and economic sustainability. Renovation of social housing and public buildings are specifically focused. Together, they will demonstrate more than 50 innovations in more than 150,000 m² of buildings.

The 9 thematic focus areas are 1) Effective planning and implementation of CPCCs, 2) Enhancing citizen engagement, environment, and well-being, 3) Sustainable building re(design) 4) Resource efficient manufacturing and construction workflows, 5) Smart integration of renewables and storage systems, 6) Effective management of energy and flexibility, 7) Continuous monitoring and evaluation, 8) New business models and financial mechanisms, policy instruments and exploitation, and 9) Effective communication, dissemination, and stakeholder outreach.



The ARV project is an Innovation Action that has received funding under the Green Deal Call LC-GD-4-1-2020 - Building and renovating in an energy and resource efficient way. The project started in January 2022 and has a project period of 4 years, until December 2025. The project is coordinated by the Norwegian University of Science and Technology and involves 35 partners from 8 different European Countries.

EXECUTIVE SUMMARY

The ARV Innovation Intelligence for Impact report 2023 is the second of a yearly series of reports presenting the innovations that the ARV project has developed, designed, and tested to help establish Climate Positive Circular Communities in Europe. The main objective of the report is to contribute to a speedy and wide scale implementation of CPCCs by putting innovative solutions on stage.

It is in the ARV ambition to produce innovative solutions that go beyond state-of-the-art and offer compelling approaches and technologies to policy makers, local change makers, and business professionals to advance the adoption of the CPCCs concept. In this second edition of the Innovation Intelligence for Impact report, 23 innovations are presented. For the 2023 edition, the innovations were clustered in six categories – namely: products/technical solutions, methods, guidelines/instructions, processes, software, and models/systems.

The report is an actionable tool for disseminating the innovative approaches of the implemented solutions within the ARV demonstration sites and processes. To this end, the report provides information about the innovative solutions in an easy to understand, yet detailed manner. The solutions are presented in a standard format to allow a smooth reading and accessible insights, and hopefully sparking the interest of the reader to dive deeper into the subject matter.

The adoption of ARV innovative solutions by other change makers is at the core of this report. Collating the demonstrated solutions in one yearly report provides a snapshot of scalable achievements to cross-fertilize the European built environment movement towards climate positivity. The report will also be presented to the ARV Exploitation Board, a group of high-level stakeholders capable of leapfrogging the innovations within their network and ecosystem of influence. By disseminating the innovations in this fashion, the ARV project invites the readers to internalize the learnings and bring them to their communities, research groups, and think how to apply them to their local context.

TABLE OF CONTENTS

1. Introduction	7
2. Objectives	8
3. Data collection and methodology	8
3.1 Overview	8
3.2 Innovation types and exploitation in ARV	9
4. ARV innovations 2022 and 2023	11
4.1 Products/Technical solutions	12
4.1.1 Comfort-driven ventilation system in social housing	12
4.1.2 Architectural and aesthetic integration of BIPV/BAPV/PVT solutions	13
4.1.3 IAQ monitoring platform	16
4.1.4 Heat pump system design	17
4.1.5 Solar PV scale smart battery systems	19
4.1.6 Climate Adapted Design Using an Innovative Surface Water Solution	20
4.1.7 Effective Application of Low-Carbon Concrete	23
4.1.8 Local Renewable energy generation using innovative BIPV and BAPV	25
4.1.9 Low-temperature thermal heating and high temperature thermal cooling (LowEx) HVAC system	27
4.2 Methods	30
4.2.1 Cost-optimal solutions for retrofitting	30
4.2.2 A catalogue of integrated circular design solutions	31
4.2.3 Timber based (new) construction, refurbishment, and superlevation scenarios	33
4.2.4 Energy transition – Living Lab educational platform for citizens	36
4.2.5 Model for involvement of tenants and citizens	38
4.2.6 Implementation of AR/VR tools and platform in decision-making process	39
4.2.7 Es Laboratori	43
4.3 Guidelines / Instructions	45
4.3.1 Social housing resilient design against climate change	45
4.3.2 Natural and mechanical ventilation concepts for climate responsive buildings	46
4.3.3 Integrated circular and resilient design for zero-emission building refurbishment	47
4.4 Software	50
4.4.1 Leanheat intelligent heating control system	50
4.4.2 Digital design for optimum life cycle performance	51
4.5 Process	53
4.5.1 Raising Climate Awareness Through Education and Local Community Engagement	53
4.6 Model/System	55
4.6.1 Urban energy geostructure in former 2x25no-m highway tunnels as seasonal storage	55
5. Conclusions	58
Future updates	59
References	60
Acknowledgements and disclaimer	60
APPENDIX A – Glossary of terms	61
APPENDIX B – Innovation type definitions	63
Partner logos	64

1. INTRODUCTION

As central features of human life, buildings furnish space in which to dwell, gather, labour, trade, make, learn, heal, and revel. Of all the things we create, buildings are the largest, and they generally persist for decades, if not centuries. How can we retrofit existing buildings and create new buildings to minimize energy use? How can we stop other, on-site sources of emissions? The aim of the Innovation Intelligence for Impact Report is to give stage to the ARV project innovations that are ready to be deployed and scaled to contribute to speedy and wide scale implementation of Climate Positive Circular Communities (CPCC). The successful implementation of CPCCs require innovative solutions on a wide range of technical and social topics, and this report is the second of an annual series presenting the innovations the ARV project has developed, designed, and tested to help create CPCCs in six different EU countries.

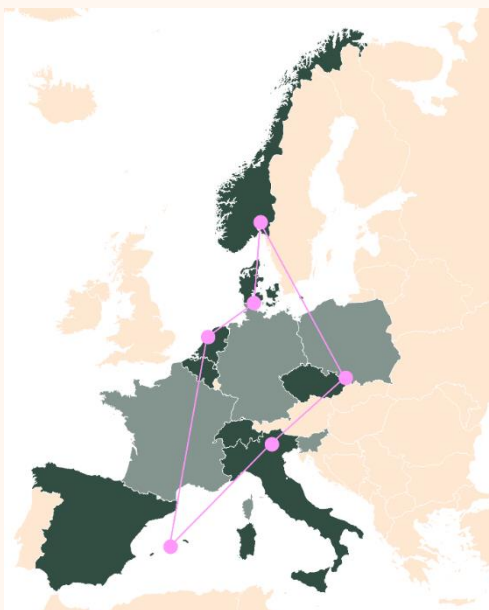

Figure 1. Map of the ARV demo projects.

The successful implementation of CPCCs requires innovative solutions on a wide range of technical and social topics. The ARV aims at providing solutions to nine thematic focus areas that present challenges and barriers to the implementation of CPCCs. The thematic focus areas are 1) Framework for CPCC planning and implementation, 2) Community engagement, environment, and well-being, 3) Sustainable building (re)design, 4) Resource efficient manufacturing and construction workflows, 5) Integrated renewable and storage systems, 6) Efficient energy management and flexibility, 7) Validation by monitoring, evaluation, and impact assessment, 8) Business models, financial instruments, policy, and exploitation, and 9) Communication, dissemination, and stakeholder outreach.

The mission of this report is to collate the ARV innovations achieved by the end of each year of the projects. It is in the ARV ambition to produce innovative solutions that go beyond state-of-the-art and offer them to policy makers, local changemakers, and business professionals to advance the adoption of the CPCC concept. The Innovation Intel for Impact report of 2023 presents 23 innovations.

A glossary of terms used in this report is given in Appendix A.

2. OBJECTIVES

Awareness, Open access, Scalability

The key objective of the report is to become a periodic lighthouse to facilitate a speedy scale-up of the ARV innovations by addressing, with innovative approaches, the nine thematic focus areas of ARV that present challenges and barriers to the implementation of CPCCs. This periodic report raises awareness amongst the built environment community of innovative solutions developed within the ARV project in an open access format and to transparently share the project results. Showcasing the innovative solutions developed in the project is a key effort in enabling the uptake of such innovations and therefore facilitating the implementation and speedy scale-up of CPCCs.

3. DATA COLLECTION AND METHODOLOGY

3.1 OVERVIEW

The methodological approach in this report is based on systematisation of the results on development of the 23 innovations in the first two years of the project implementation, with the aim of showcasing the innovations that have been demonstrated so far. In this context, the possibilities of further exploitation of the innovations are explored, as well as the replication and future use and applicability.

As part of the Climate Positive Circular Communities Innovation Forum and key elements of this work, GDFA and NTNU have developed an online innovation management tool: ARV Innovations Tracker (see Figure 2). The Tracker is a web-based tool that showcases key information about all project innovations and offers an easy way to view and filter the innovations by parameters such as demonstration site, associated WP, leading organisation, and due date for delivery. This not only paves the way to systematically supporting the annual report on ARV Innovation Intelligence for Impact, but also offers the ARV Consortium an instrument to cluster innovations, learn from each other experiences, and discuss commonalities. The broader goal is to collect, analyse, and disseminate innovations to facilitate knowledge exchange and outreach with the ARV Exploitation Board to ensure early identification and to scale commercially viable innovations.

All key information about ARV innovations in the Tracker has been collected through the ARV Innovation Survey, which is a living tool. The key information related to the current and expected readiness levels of the innovations and the overall level of the development, targets group and expected impacts and its exploitation pathways, are collected through the ARV Innovation Survey bi-annually, according to the established innovation management approach (D1.3 Innovation Management Plan²). For each of the ARV innovations, an Innovation Lead is appointed as the main responsible for developing and testing the innovation.

² ARV D1.3 Innovation Management Plan (2023), second version V.12 (confidential)

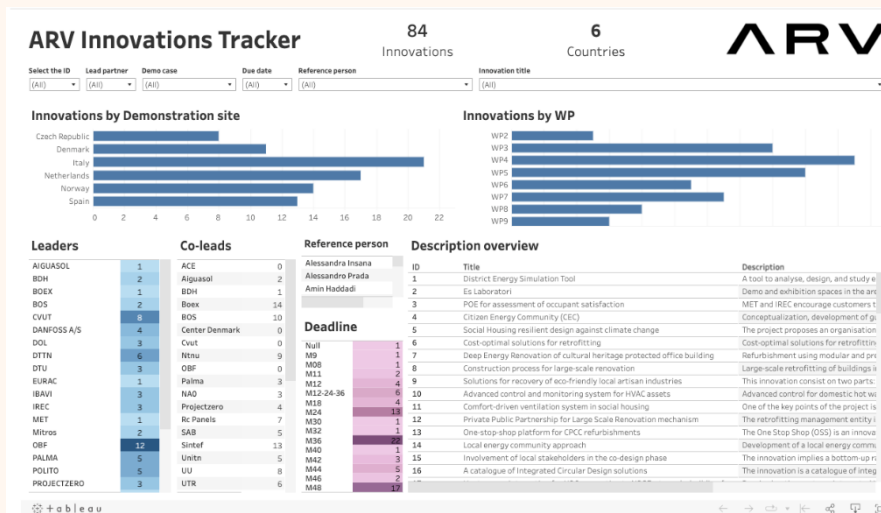

Figure 2. ARV Innovations Tracker

3.2 INNOVATION TYPES AND EXPLOITATION IN ARV

The project innovations are categorised into seven main categories: product/technical solution, process, method, model/system, database, software, and guideline/instruction (see Annex B for definitions of each category). This standardisation of the innovations and results allows us to analyse and disseminate demonstrated innovations across the project in a systematic way, considering the specific characteristics and differences between the innovation types, intended target groups, expected impacts and exploitation pathways.

ARV innovations have the potential to be commercially exploited as products or services by the partners in the ARV consortium. The exploitation pathways for the innovations will be developed in close cooperation with the ARV Exploitation board, which will be established in Task 9.5 as a vehicle for scaling the business models and financing instruments. The Exploitation Board will be composed of strong innovation clusters and financial sector players that will spread the green building and renovation concepts, to provide momentum to the ‘renovation wave’ that will be politically underpinned. The Innovation Clusters bring together key stakeholders from the whole value chain of CPCCs: Knowledge institutes, tech and system providers, energy service providers, architects, real estate and building owners, municipalities and regional authorities, financial institutes, and different organizations working to promote sustainable buildings and communities.

As an important segment of the further exploitation and dissemination pathways of the achieved results, the ARV eMarketplace (Figure 3) will enable the aggregation of all the project results, innovations, technology providers, and service providers. The eMarketplace will include the necessary tools to streamline the process and deliver the necessary services and installations, and the financing mechanisms put in place will facilitate their uptake. The key results presented in the Innovation Intelligence for Impact report will be further disseminated through the eMarketplace, beginning of 2024, and led by Housing Europe.

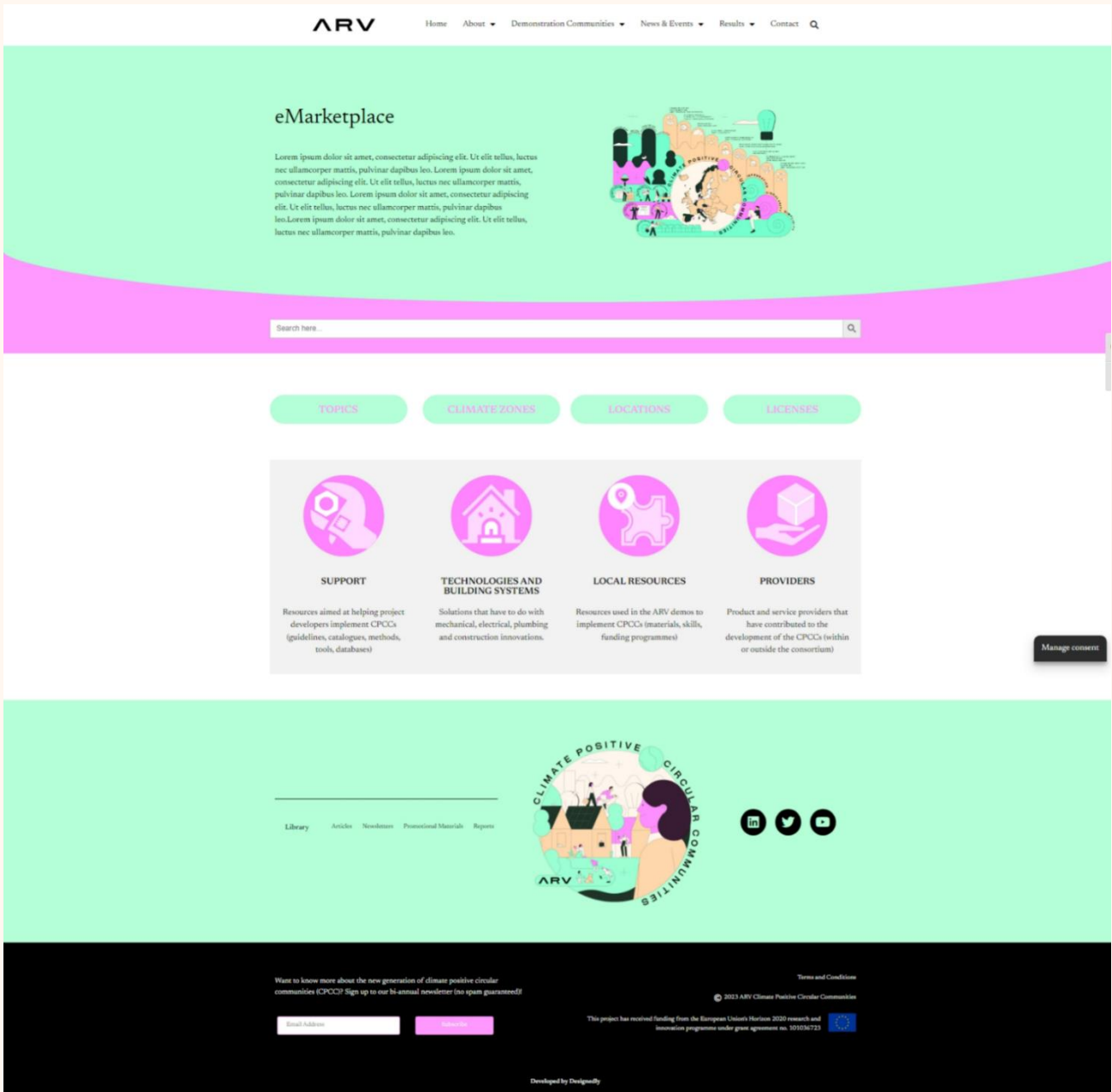

Figure 3. eMarketplace on the ARV project website³

³ eMarketplace · ARV (<https://greendeal-arv.eu/emarketplace/>) (Assessed 7 December 2023)

4. ARV INNOVATIONS 2022 AND 2023

The completed ARV innovations of 2022 and 2023 are composed of a wide range of technical and social expertise and categorised according to their nature into one or more of the ARV innovation categories.

For the 2022 edition, the innovations were clustered in three solutions approaches: knowledge solutions, engineering solutions, and material solutions. The reason why these clusters were selected is because the report wants to be an easy to navigate catalogue of innovations for the public, but also for subject matter experts. In this edition, a total seven innovation clusters have been identified, namely: product/technical solution, process, method, model/system, database, software, and guideline/instruction. Nevertheless, in the next two editions of the report, the cluster may change due to the impact areas of the innovations themselves.

This report presents 23 innovations achieved so far in the ARV project. Some innovations can have characteristics from multiple categories, in which case the most descriptive category has been used. The structure of each innovation follows a simple description section followed by five paragraphs where the lead authors have responded to a few key, yet straightforward questions about the innovation and reflect the challenges it aims to solve, the intended target groups, and the application and scalability potentials and possible exploitation pathways. This structured approach provides a guiding principle of simplicity yet with a rich amount of information. Illustrative visuals and diagrams are also provided.

Figure 4 offers a visual breakdown of the innovations divided into ARV's innovation categories.

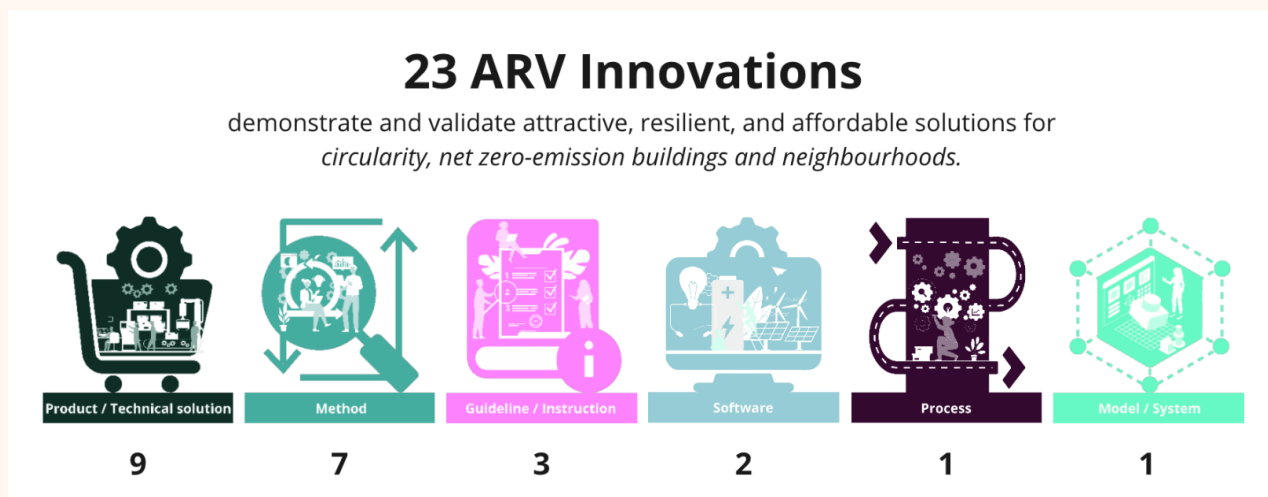

Figure 4. Innovation categories of the reported ARV innovations.
Graphics: Jesus Daniel Garcia Melo, NTNU.

4.1 PRODUCTS/TECHNICAL SOLUTIONS

This section contains the physical or virtual products, or a combination of hardware and software achieved within the first two years of the ARV project. In 2022 and 2023, 10 innovations in this category were achieved. Many of these innovations are characterised by an engineering component that produces an advancement in the technological level of a specific appliance. Others revolve around production materials to ensure lower embodied carbon emissions of new buildings or retrofitted ones. For example, timber-based construction is an area where ARV presents innovative solutions. Great advancements have also been made in reducing the operational carbon footprint of buildings by the integration of renewable energy technologies into the buildings' energy systems.



4.1.1 COMFORT-DRIVEN VENTILATION SYSTEM IN SOCIAL HOUSING

Description

One of the key points of the project is to allow for adaptability of the building based on the external climate conditions. Through automatically regulated bioclimatic elements, it is possible to ventilate in summer or capture and conserve heat in winter. These bioclimatic elements can be related to each apartment individually. One of the most important problems associated with heating during the winter is linked to the minimum ventilation required by regulations. One of the strategies adopted to reduce heat losses is to use the variable flow ventilation method. This ventilation allows the air to be heated previously before introducing it into the home through bioclimatic capturing spaces that act as a thermal intermediate space and reduce losses.

CO₂, temperature, and humidity sensors will be installed in each room of the apartments, including the galleries. Those sensors will be connected to motorised windows that will open and close depending on the data collected to keep maximum comfort levels.

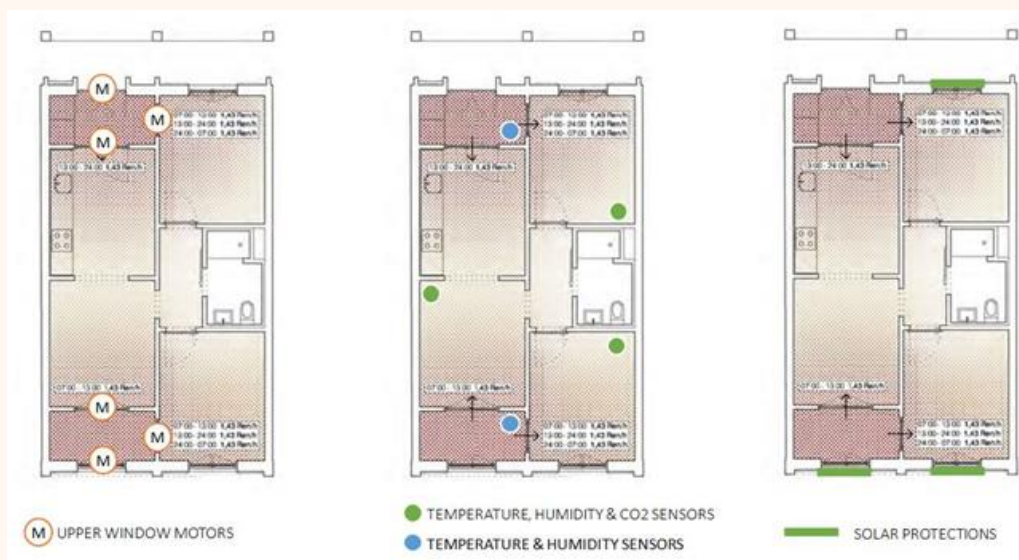

Figure 5. Placement of window motors, sensors and solar protections in an apartment.

What challenge does it solve?

The management of both the thermal intermediate spaces and the atriums is very important as they allow systems to be optimised and construction materials to be saved. However, if the management of

these spaces is not adequate, imbalances could occur in the interior, causing overheating in the summer - if there is no ventilation or sufficient protection - or cold temperatures in the winter - if the capturing potential is not taken advantage of. Therefore, the innovation reduces energy losses during air renewal and reduces energy demand by using preheated air. This automatic system will minimise effort required by the user providing maximum comfort.

Who is it for?

Constructors, Architects, Tenants, Research community and educational institutions

How can it be applied and scaled?

Research activities, Patenting

Demonstrated in Palma de Mallorca, Spain



4.1.2 ARCHITECTURAL AND AESTHETIC INTEGRATION OF BIPV/BAPV/PVT SOLUTIONS

Description

This activity explores the integration of technical systems, such as solar thermal and photovoltaic solutions, in the vertical building envelope. The experimentation of new solutions – accompanied by new European standards on integrated building envelopes developed by the scientific community and partnerships between the PV industries and the glass sector – has had important repercussions aesthetically and architecturally, resulting in a new generation of architecture representative of green deal challenges. Since the turn of the century, energy efficiency objectives in Europe have conditioned architectural concepts from a morphological point of view, starting from the surface-shape relationship of buildings, and today the new forms of integration between building and energy production systems are creating opportunities for developing a new aesthetic, technological and construction language. In the ARV project, this thesis was developed as part of the ecosystem of the Autonomous Province of Trento, where the companies in the building sector are strongly oriented towards the development of industrialized products and off-site solutions for architecture, in particular engineered wood components sector. Therefore, the aim was to experiment with plant-systems integration in an industrialized building envelope system produced in a factory. Incorporating a prefabricated envelope system and an industrialised product allows for a relationship between the various components, including the technical energy systems (PV, HVAC, etc.).

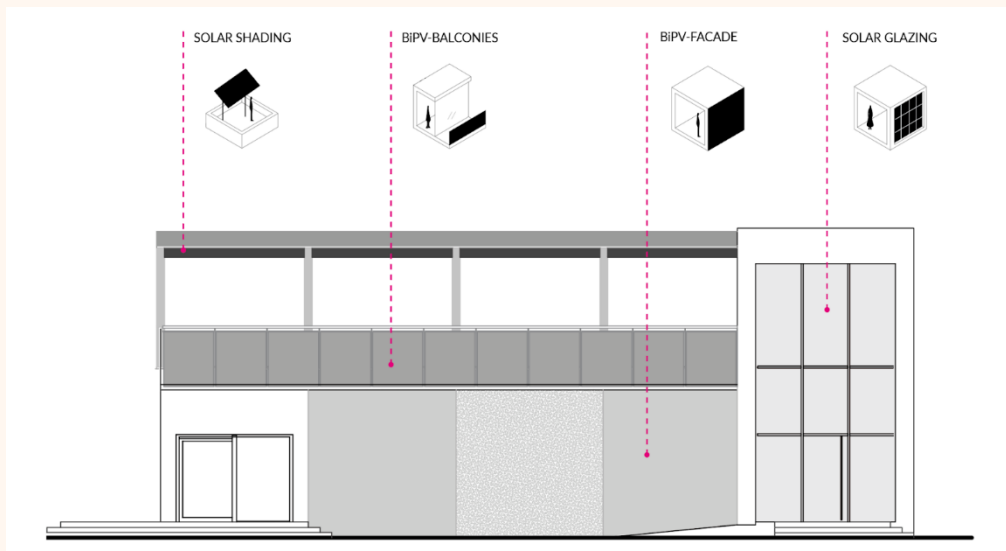

Figure 6. Photovoltaic integration forms identified on the envelope of the Demo Project Trento, South facade. Original graphics by Guido Callegari, Politecnico di Torino.

The innovation is currently patent pending⁴ and refers to a prefabricated PVT (PhotoVoltaic Thermal technology) module ready to be integrated into the building envelope as an active façade system offering considerable adaptability to the various structural configurations of the façade (PVT Module / Type 1). Several full-scale mock-ups of the module have been produced to analyse the technical solutions and start testing the physical module's behaviour. Further experiments of the prefabricated PVT module will be proposed in the ARV demo project in Trento, testing the potential of innovation in the context of the integration between the PVT module and the decentralized heat recovery mechanical ventilation system (PVT Module / Type 2). Both technologies will be integrated into a prefabricated timber wall ready to be installed as an exterior facade in the wooden structures of the demo project building (Figure 7).

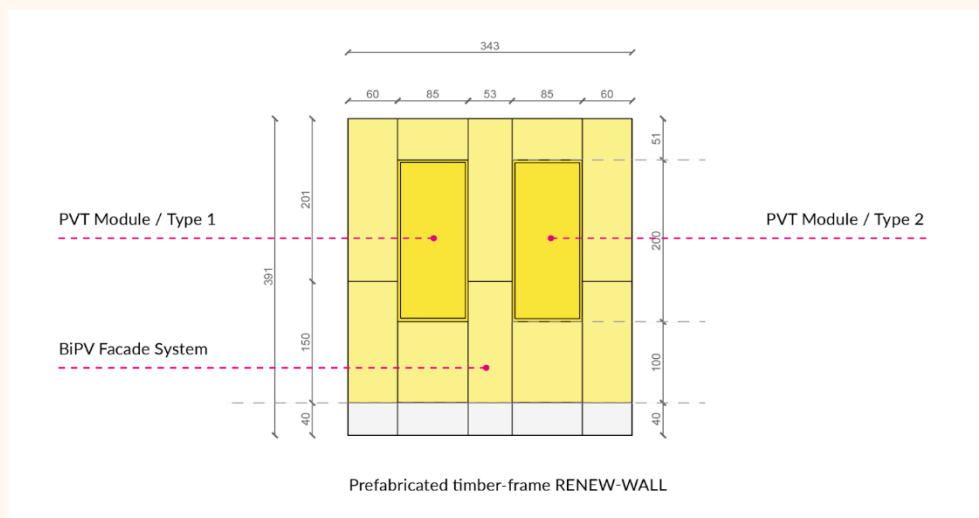

Figure 7. Demo Project Trento, South facade: PVT modules installed in the BIPV facade. Original graphics by Guido Callegari, Politecnico di Torino.

⁴ Patent pending "Modulo solare ibrido fotovoltaico e termico" (I0200930) BR EFF&GIEMME / application number 102023000017145, submission date 10/08/2023

A significant contribution of the demo project will also be defining specific design guidelines for constructive and technological architectural integration of BIPV components in architecture (Figure 8), starting from a study and critical analysis the researchers conducted in some of their recent research⁵.

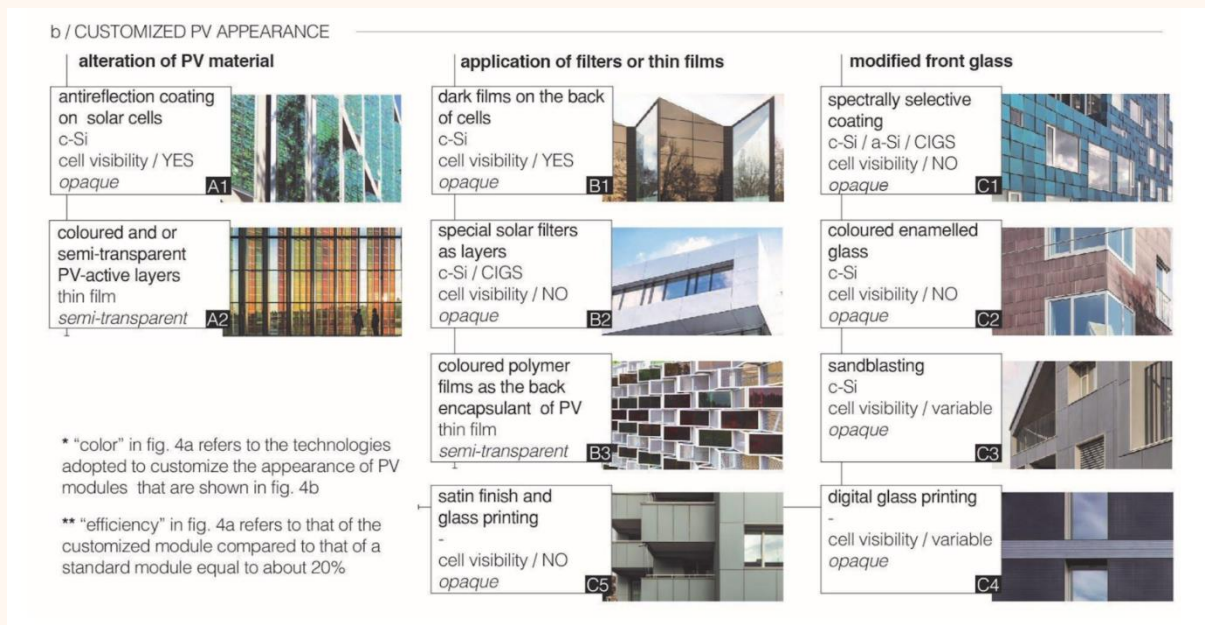

Figure 8. PV products overview. The graphic illustrates the current colouring technologies for PV components and the range of different formal interpretations. Original graphics by Guido Callegari, Politecnico di Torino.

What challenge does it solve?

1) Driving the production process of the BIPV envelope system in off-site industrialised architectures makes it possible to analyse, with greater control, the possible strategies for integration of the various plant systems and transparent or opaque envelope components, with adequate verification of performance compared to standard on-site construction practices.

2) The design of a BIPV technological envelope to be produced as an industrialised component in the factory will facilitate economies of scale in planning the final cost of the product, an aspect that today constitutes a deterrent to experimentation in many European countries.

Who is it for?

Facade systems and prefabricated walls constructors, photovoltaic systems suppliers, constructors, architects, municipalities, policy makers and regulators / authorities, research community and educational institutions.

How can it be applied and scaled?

The PVT solutions can be adapted to both the new construction market and the redevelopment of the existing building stock through modifications of the envelope layers. This customization is more feasible if the component production processes are industrialised. The PVT solutions starting from different market and design needs, can either be a repeatable "wall module" to define an envelope system or be integrated within the window system. This can accelerate the shift of the BIPV/PVT market from today's

⁵ G. Callegari, E. Merolla, P. Simeone, "Photovoltaic breakthrough in architecture: integration and innovation best practice", in *CONF.ITECH 2022. Technological imagination in the green and digital transition. Conference proceedings*, Springer, Switzerland, 2022, ISBN: 978-3-031-29517-1.

dry construction system towards a system of three-dimensional industrialized components belonging to Industry 4.0 patterns, which increasingly involve the construction sector.

Demonstrated in Trento, Italy



4.1.3 IAQ MONITORING PLATFORM

Description

The IAQ platform is a combined Indoor Air Quality (IAQ) sensor and a user-friendly web interface. The IAQ sensor measures various quantities defining the indoor environment such as temperature, humidity, CO₂ concentration, VOC concentration, particulate matter (optional), and barometric pressure. The measured quantities are then used to inform the user, directly control technology in the building (AHU, HVAC), or provide necessary data to a superior system via Wi-Fi, LoRa WAN (optional), Modbus TCP (over Wi-Fi), RS485 with Modbus RTU. The sensor is equipped with a RGB LED indicator or LCD display.

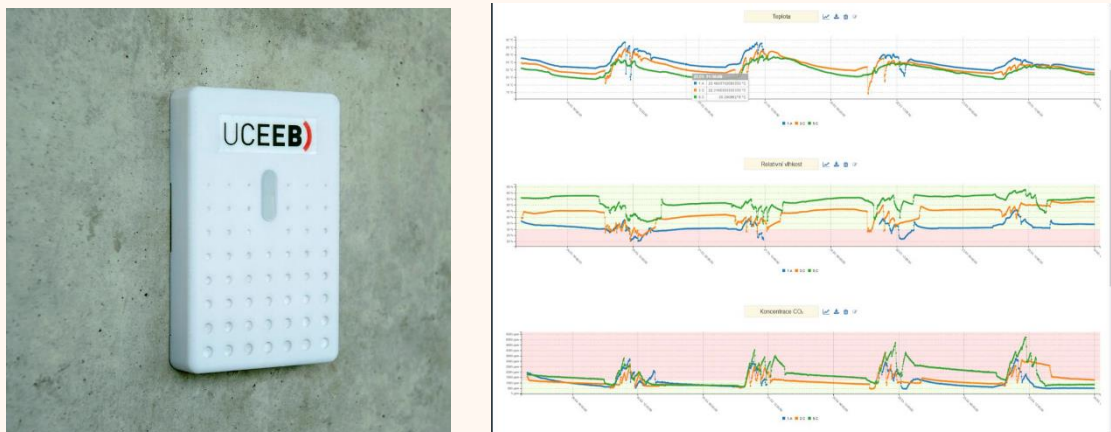

Figure 9. The IAQ monitor and web interface

What challenge does it solve?

The IAQ platform monitors the space we live in and helps us to maintain the environment. Sensor provides comprehensive evaluation of indoor quality. The users can easily view measured data in the web interface, which also allows to view history and settings to improve the environment.

Who is it for?

Building owners, Tenants, Landlords, Municipalities. The IAQ platform is meant both for residential and commercial areas. In family houses and flats, the sensor can control the systems based on user's behaviour and provide a signal to open the windows to let the fresh air in. In commercial areas, the sensor can be used to automatically maintain a proper indoor environment by controlling air handling units as a component of a complex BMS system. In both cases, it provides monitoring data for long-term evaluation of indoor environment conditions. This can further help improve the environment which is so important for us.

How can it be applied and scaled?

The IAQ platform is a product solution that is ready for the market. Different types of business models can be introduced to scale the potential of application and penetration in residential and commercial areas.

Demonstrated in Karviná, Czech Republic



4.1.4 HEAT PUMP SYSTEM DESIGN

Description

The aftercooling concept is an innovative district heating substation for large multi-apartment buildings where the domestic hot water preparation and reheating of the circulation flows are decoupled and obtained in two separate heat exchangers connected in parallel. The primary return temperature flow from the circulation heat exchanger is further aftercooled by the space heating system before returning to the district heating network (Figure 10). The concept provides a reduced return temperature to the district heating network.

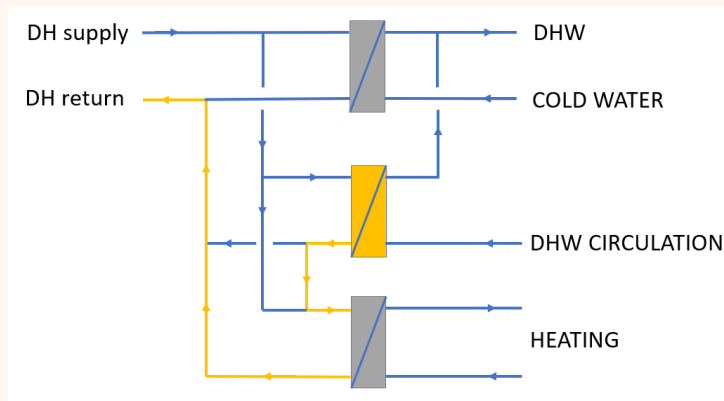

Figure 10. Operating diagram of the aftercooling system

What challenge does it solve?

The key ability of the future district heating system is to operate at lower network temperatures. The aftercooling system reduces the return temperature from the building, and this is often a precondition for being able to reduce the district heating supply temperature. Lower network temperatures make it possible to utilise low temperature surplus energy sources that otherwise would be wasted or would require a temperature lift by e.g., a heat pump. Further it reduces the thermal distribution losses from the district heating network. The potential for district heating return temperature reduction is 4-8°C on yearly level for typical buildings, which is significant.

The figure 11 shows the calculated yearly building level district heating return temperature reduction potential, as a function of the dimensionless parameters R1 and R2, based on the yearly energy demand

for SH: space heating, DHW: domestic hot water and CIRC: domestic hot water circulation. Besides this, the district heating and space heating temperature profiles typical for 3rd generation district heating is applied. The Sønderborg SAB department 22 is shown as building case DK#6, and for this building case the potential is 5°C.

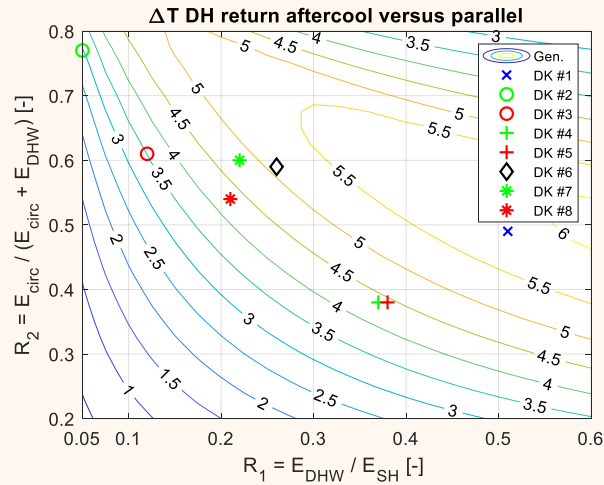

Figure 11. Calculated yearly building level district heating return temperature reduction potential.

Who is it for?

The developed aftercooling system is relevant where a traditional district heating substation is to be installed or to be updated, typical residential and commercial buildings, and where there is domestic hot water circulation service provided. The concept is relevant for service providers, real-estate representatives, building owners, landlords, associations (cooperatives), municipalities, district heating utilities, and basically, all groups benefitting from a more energy efficient building level district heating substation. Critical for the deployment of the concept is that the district heating utilities establishes an economic bonus scheme awarding a reduced district heating return temperature. This is the case in Denmark and partly in Sweden, but it's not widely spread.

How can it be applied and scaled?

This innovation focuses on the development of the aftercooling concept and the analysis of the district heating return reduction potential.

Demonstrated in Sønderborg, Denmark



4.1.5 SOLAR PV SCALE SMART BATTERY SYSTEMS

Description

The purpose of this innovation is to demonstrate and monitor the combination of solar PV panels and battery systems in large residential buildings and to develop design criteria for such combined systems. Further, the innovation focuses on architectural aspects, economical aspects, and dialogues with authorities. The demonstration project includes 19 apartment blocks of 3 floors, in total 432 apartments with a floor area of 32,000 m², located in Sønderborg, Denmark.



Figure 12. SAB Department 22 with roof integrated solar cells

What challenge does it solve?

The electricity consumption in housing blocks has its peak in late afternoons and evenings. The production of solar electricity, however, peaks during daytime. Therefore, it is important to store solar electricity from daytime to late afternoons and evenings. Without batteries, the excess produced solar electricity has to be sold to the public grid for a low price 0.08 Euro per kWh. If the solar electricity can be stored in batteries and used in the evenings, tenants will be able to save 0.35 Euro per kWh, which is the normal price for electricity in Denmark (2023). Installing batteries in combination with solar PV also contributes to reducing the peak load demand on the public grid.



Figure13. 15 kWh battery unit and battery inverter for 1 of the 19 housing blocks

Who is it for?

The target group for batteries in combination with solar PV systems is primarily private or social housing blocks and public institutions, where people live in buildings with a common main electricity meter combined with internal electricity meters in the apartments.

How can it be applied and scaled?

Battery storage solutions combined with solar PV panels are still under technological development. Lithium batteries are available on the market, and commercial activities are ongoing. Materials used for manufacturing lithium batteries, however, are in the category “products with low sustainability”. Alternative battery solutions are in a beginning development phase, especially the so called “flow batteries” based on more sustainable materials instead of lithium batteries. As soon as new and more sustainable materials are available for batteries, the market for combined solar PV and battery systems is expected to grow noticeably, because this solution will be economical feasible.

Demonstrated in Sønderborg, Denmark



4.1.6 CLIMATE ADAPTED DESIGN USING AN INNOVATIVE SURFACE WATER SOLUTION

Description

The Regulatory plan of the Voldsløkka area in Oslo, Norway, required that the school courtyard is to be developed as a park with a variety of vegetation at different heights and with permeable surfaces and natural surfaces covering at least 30% of the outdoor flooring. A strategy for local and open surface water management was recommended for the area to avoid the rainwater runoff from damaging buildings, properties, and infrastructures and creating inconveniences to the local residents. The



Figure 15. Scheme of storm water management in one of the project's islands.
Original image by ØSTENGEN & BERGO AS, edited by Nicola Lolli (SINTEF).

What challenge does it solve?

The City of Oslo's work on stormwater management is a critical initiative for the city to become climate resilient. Numerous measures have been implemented since the Stormwater Management Action Plan was considered at political level in 2019 (proposition 291/19)⁶. Oslo Municipality promotes the use of open, local surface water management to contrast the damage to buildings and infrastructure produced by poor rainwater management. Such a problem is exacerbated by climate change, which in the Nordics will lead to more rain and sudden heavy rainfall. By opening closed streams and rivers and using green roofs and draining surfaces instead of asphalt, rainwater flows are slowed down and the risk of flooding reduced. The demonstration of this innovation in the Voldsløkka project aims at showing how technological solutions for effective local storm water management can be designed and implemented by integrating educational purposes and without sacrificing the aesthetic of a natural environment within city borders.

Who is it for?

Material providers and portfolio managers, Constructors, Architects, Municipalities, Policy makers and regulators / authorities, Research community and educational institutions

How can it be applied and scaled?

This innovative storm water management system will be fully operative from August 2023. It will be used to demonstrate the effectiveness of such solutions and its technical limitations (durability of materials, growing rate and health of vegetation, effectiveness of stormwater outflows over time) in relation to the replicability potential in other geographical areas.

The City of Oslo is expected to develop and complete thematic maps for stormwater and urban flooding and a Stormwater Management Guide, in 2023. The City of Oslo's property enterprise is working actively to develop and implement effective stormwater solutions on municipal land. There are currently 15 construction projects in which stormwater management has been integrated through the use of green roofs and other nature-based solutions. Work is underway on the development of a stormwater management communication strategy with the aim of strengthening the communication work relating to stormwater management. New or revised instruments will be introduced to strengthen the efforts towards The City of Oslo resiliency and robustness against climate change. The aim is to consider to a larger extent current and future natural events which are being exacerbated by climate change. This

⁶ <https://www.klimaoslo.no/article/follow-up-of-the-climate-strategy/>

strategy will consider an increased effort for the preservation and development of blue-green structures, further development of the Green Inventory, and the strengthening of risk and vulnerability analyses in planning processes, with a particular focus on ground conditions. The criteria for stormwater management and blue-green structures are of particular importance for ensuring climate adaptation. Since 2021, these criteria are also used in area regulations. The regulations concerning the blue-green factor set out minimum requirements for nature-based solutions in connection with land use.

Demonstrated in Oslo, Norway



4.1.7 EFFECTIVE APPLICATION OF LOW-CARBON CONCRETE

Description

Low-carbon concrete with 40% lower embodied emissions than the current standard has effectively been applied in the Voldsløkka demo site in Oslo. The low-carbon concrete class A⁷ used in Voldsløkka typically has CO₂ emissions of 220-240 kg/m³, depending on use, whereas a typical concrete has an emission-factor of 400-410 kg/m³. Concrete is used in the parts of the building adjacent to the ground.



Photo credit: Jan Eldegard Hjelle

What challenge does it solve?

Besides water, concrete is the highest consumed material in the world. It is used to produce and build the vast majority of the world's buildings, bridges, roads, dams, and several other constructions. Cement production alone is responsible for approximately 8% of the world's CO₂ emissions. Reducing the amount of the emissions related to cement and concrete production will have a major impact on global CO₂ emissions. The emissions related to building in concrete stems, to a very large degree, from the

⁷ Norwegian Concrete Association publication NB37, which defines class limits for greenhouse gas emissions for four different levels of low-carbon concrete.

production of the cement (as the critical ingredient in concrete) and has a large potential for emissions reductions. In addition, construction techniques and optimization of amounts of concrete used in various structures can reduce emissions through the simple fact that less material is used. In the Voldsløkka school both these emission-reduction pathways have been utilized to reduce the CO₂ footprint. So-called low-carbon concrete, with CO₂ emissions 40% lower than standard concrete has been used. In addition, concrete has only been used in critical parts of the structure, replacing it with wooden structures in other parts of the building load-bearing structure.

Who is it for?

Material providers and portfolio managers, Constructors, Architects, Research community and educational institutions. Expanding knowledge about new types of concrete will be interesting for all the actors of the building industry as concrete is one of the materials with the highest carbon footprint and one of the most utilized building materials in the world.

How can it be applied and scaled?

Given the widespread use of concrete as a building material, the replacement of only a small fraction of the total amount of concrete used worldwide can cause significant CO₂ emission reductions.

In general, there are several technical challenges with concrete where high amounts of cement are replaced by supplementary cementitious materials (SCMs). With reduced cement content and increased other additions, the early strength and, depending on the composition of the binder, also long-term strength development will be reduced. Furthermore, some durability properties might be reduced while others will be increased. Usually, resistance to alkali silica reactions as well as chloride ingress is increased for properly cured concrete with low carbon binders. On the other hand, resistance to carbonation in buildings and frost-salt scaling in infrastructure concrete may decrease and remains a challenge. High replacement of cement with SCMs and decreased amount of cement in low carbon concrete also has an impact on the workability (flow properties) and handling of the concrete. Hence, it is often necessary to increase the number of chemical admixtures to guarantee similar workability and strength development. Still, for low carbon concrete type A, with about 40% CO₂ reduction potential compared to a reference concrete, many of these challenges are solved. Today, the SCM used in these types of concrete on the Norwegian market is fly ash (from coal fired power plants). However, the amount of available fly ash will decrease in the future and cement producers are starting to look at alternative SCMs to replace cement. In a recently finished research project (NEWSCEM⁸) promising alternatives have been found. In the second phase of this project (ZeroCarbCon⁹) the aim is to develop novel CEM II/C products (50% replacement of Portland Cement) for use in building and infrastructure concrete. Research is needed to understand these novel binders with these new types of SCM to gain similar good results as today with fly ash from coal incineration plants.

The Norwegian Concrete Association has published a carbon classification system for concrete (NB37) which the concrete industry has used for several years. Good results have been obtained in practice with low carbon concrete type A according to this classification (approx. 40 % lower CO₂ than reference), and the market demand for this material has increased. The more difficult part is to implement low carbon concrete type "Pluss" and "Extreme" with even lower CO₂ emissions (50-60% reduction). A remaining challenge is to increase the demand further by building up competence through information campaigns, manuals, and guidelines for a common and easy understanding of how to use and apply these types of concretes.

⁸ <https://www.ntnu.edu/kt/research/concrete/projects/newscem>

⁹ <https://www.ntnu.edu/kt/research/concrete/projects/zerocarbccon>

Demonstrated in Oslo, Norway



4.1.8 LOCAL RENEWABLE ENERGY GENERATION USING INNOVATIVE BIPV AND BAPV

Description

Coloured PV panels are installed on the roof and façade of the school building in the Voldsløkka project to provide an overall energy production of 230 000 kWh/year. This is equal to 2 kWh/m² per year of excess electricity production, making the school a plus-energy building. The design of the PV modules layouts is defined by the PV modules orientation in relation to the sky, the orientation of the school building longest façades, and the regulatory provision regarding the appearance of the PV façade. The building's North-South orientation is not optimal for PV production, as the longest façades are facing either East or West, thus not taking advantage of the higher insolation on South-facing façades. In addition, the regulatory provision requested the school façade not to resemble that of an office building, meaning that solutions that entail large and monotonous surfaces with PV panels were not accepted. The challenge was therefore to overcome the combined limitations given by the not-optimal building orientation, the need for variety of the façade appearance, and the highly ambitious energy goal for the building. The choice of using different shades of green and black for the PV panels, and the rotation of their vertical axis (as shown in Figure 16) was given by the necessity of avoiding a uniform and monotonous look of the façade.



Figure 16. West façade of the school building.
Original image by KONTUR and SPINN Arkitekter, edited by Nicola Lolli (SINTEF).



Figure 17. South façade of the school building.
Original image by KONTUR and SPINN Arkitekter, edited by Nicola Lolli (SINTEF).

What challenge does it solve?

One aim of the school building project is to deliver excess electricity to the grid in order for the school to be a plus-energy building. This can be achieved by making use of large quantities of standard black PV modules on the facades, at the expenses of aesthetic expression and architectural quality of the building. The challenge was therefore to show that it is possible to deliver such an excess of electricity and at the same time propose an appealing architectural expression for the building facades. This was obtained by using combinations of black and bi-coloured PV panels which are oriented at a 20-degree angle on the horizon (Figure 18). The rotation of the panels reduces the space for allocating the PV modules due to the panels cuts around windows and at the façade border. To achieve the planned energy target for the building, parametric design tools were used to calculate the allowed amount of PV modules at varying angles of the panels' orientation. The corresponding electricity production was thereafter calculated for the various orientations and resulting number of modules.

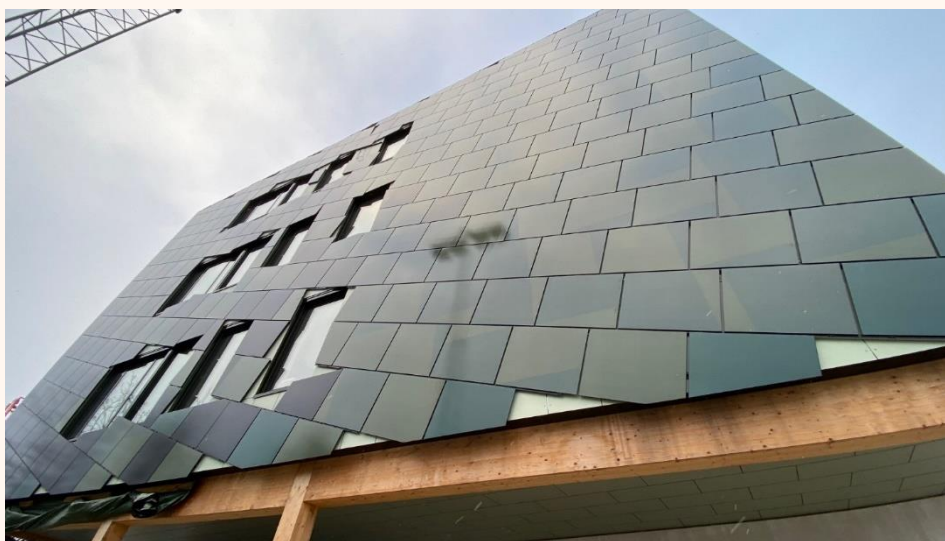

Figure 18. Picture of the mounted BIPV-modules on one of the Voldsløkka facades.
Photo: Bodil Motzke, Oslobygg.

Who is it for?

Material providers and portfolio managers, architects, building owners, municipalities, research community and educational institutions. Using solar energy to reduce the need of energy from the grid is an interesting technology since the technology is clean and the energy can be applied directly to use.

How can it be applied and scaled?

The PV panels are mounted on an aluminium profile system which is composed of a main system with vertical element spaced every 600 mm and a secondary system, with horizontal elements aligned to a 20-degree angle from the horizon. Where the secondary profile system partially overlaps with the windows behind, glass panels are installed instead of PV panels. These glass panels match the colour variations used for the PV panels. The number of total glass panels is about 15% of the total number of PV panels. The ratio of the green-coloured modules and black modules is about 25% for the modules on the west facade and about 40% on the south facade are black. All other modules come with two different shades of green, in such a way that each PV panel consists of two different, green-coloured parts. Two different combinations of the bi-coloured panels are used, as shown in Figure 18. These panels are installed either in an upright position or rotated by 180 degrees. This is to make the impression that 4 different panels are installed on the facade. An equal number of panels of each of these two-colour combinations is installed on the facades.

The application of such a design demonstrates the feasibility of large PV-integrated facades to meet a plus-energy building target and at the same time provide an appealing and dynamic architectural expression.

Demonstrated in Oslo, Norway



4.1.9 LOW-TEMPERATURE THERMAL HEATING AND HIGH TEMPERATURE THERMAL COOLING (LOWEX) HVAC SYSTEM

Description

This low-temperature heating and high temperature cooling HVAC system (LowEx) is a novel system which delivers low-temperature thermal heating and high temperature thermal cooling by using the infrastructure coupled with the ground source heat pump. It is designed to maximize the effectiveness of ground source heat pump systems. The individual components of the system are not novel in themselves; however, the novelty is in how they are designed to work optimally together. The coefficient of performance (COP) of heat pumps is mainly determined by the temperature difference between the source and the emitting temperature. COP shows the ratio between useful heat and compressor power as input energy. By minimizing the temperature difference between the source and the emitter, the COP is maximized. The system is designed to operate with supply temperatures of the HVAC system that are very close to the desired room temperature. To enable this, the system utilizes a combined radiant heating and cooling system allowing for temperature differences between the room design temperature and the fluid, as low as 5°K. In this way, the high performance of the heat pump results in energy needs as low as 3 to 10 kWh/m² year and greatly reduces the compressor power peak. The LowEx system is

integrated in the demo project in Oslo (Voldsløkka) by using the existing infrastructure, thus saving cost and embodied energy from material use.

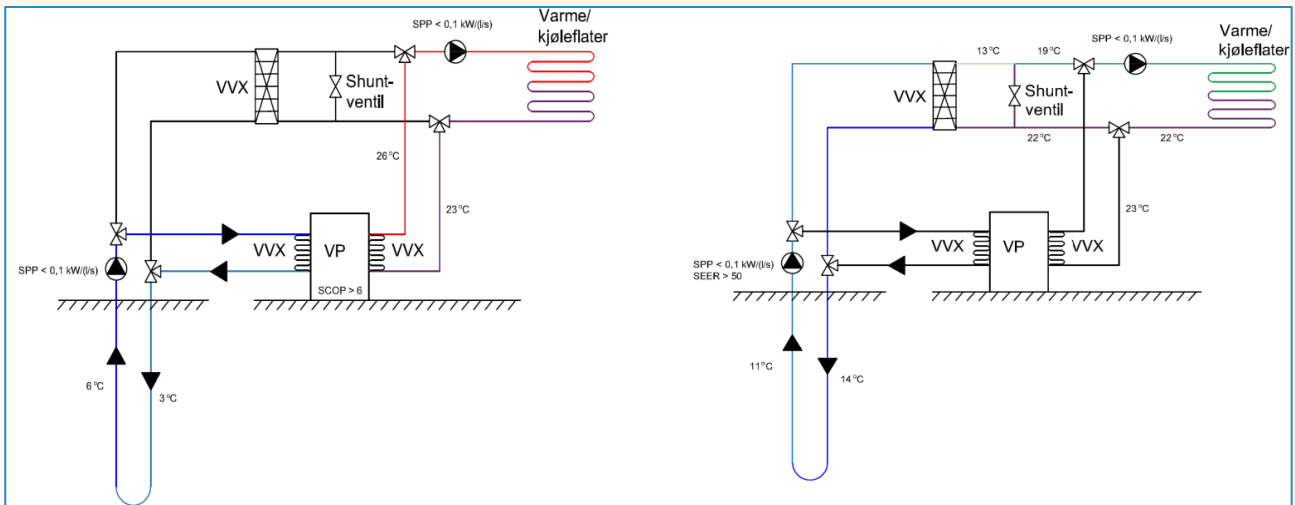

Figure 19. Schematic of the LowEx system, in winter operation (left) and summer operation (right).
Source: Tor Helge Dokka, Skanska Norway.

What challenge does it solve?

By reducing the energy needs for heating and cooling, the local renewable energy production can be used for addressing other buildings end-uses (lighting, ventilation, appliances) which are less dependent on seasonality, thus reducing the yearly mismatch between the PV production and the buildings' energy use. The LowEx system is integrated by using the existing infrastructure, thus saving cost and embodied energy from material use. The same can be said about the use of a common system for heating and cooling, resulting in less need for piping and heating and cooling emitters. The use of high temperature cooling makes it possible to utilize free cooling from the energy wells to a much larger extent than in traditional systems, because cooling from the wells can be directly utilized even when the temperature of the water from the borehole rises towards 19 °C.

Who is it for?

Constructors, Architects, Service providers, Building owners, Research community and educational institutions. This technology is interesting for many actors as it reduces the need of energy from the grid, it is clean, and the energy can be applied directly to use efficiently. The technology has scaling potential as it reduces the energy cost for building owners. Hence the constructors, architects and service providers will benefit from more practical knowledge about the technology to be able to provide it to meet the demand.

How can it be applied and scaled?

The system works well for both small and large buildings. Due to beneficial temperature levels in the hydronic system of HVAC, the heat pump system performance will increase. The more efficient the building envelope is, the more efficient the LowEx system will be. With lower demand, the lower temperature difference between the emitter and the room can be, thus increasing the heat pump performance. The system is well suited for all new energy efficient buildings and in deep renovation processes. However, the system requires installation of radiant heat tubing, which could be challenging in some renovation projects.

In the Oslo demo project, the LowEx system will be demonstrated, followed up, and evaluated. Building energy flexibility is recognized as an important property of the future. Flexibility enables a building (or group of buildings) to shift its energy demand in time, either as response to an external signal from the

grid, or to optimize its self-use of locally produced electricity. The way the LowEx system integrates its heating and cooling system into the building construction, enables efficient activation of the building thermal mass. This makes the building well prepared to be an active asset in the future energy market.

Demonstrated in Oslo, Norway



4.2 METHODS

This section includes method innovations, meaning a particular and systematic way something is done in the ARV project. These may be tools, methods, catalogues, and approaches to drive CPCCs strategy development, management techniques, collaboration mechanisms, knowledge sharing and learning, as well as knowledge capture and storage. These solutions strive to improve understanding, collaboration, and process alignment.

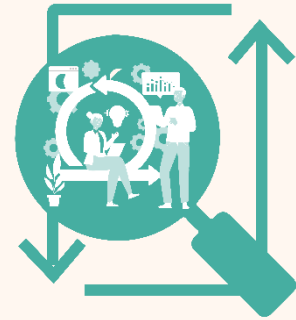

4.2.1 COST-OPTIMAL SOLUTIONS FOR RETROFITTING

Description

The innovation is a two-step methodology that aims to select the cost-optimal solutions for retrofitting of buildings in large-scale renovation process (200-300 dwellings). From a set of different potential combinations of passive elements (e.g., adding different insulation materials with different thickness and/or windows) and active elements (e.g., heat pumps / multi-split air conditioning for heating, cooling and DHW and/or photovoltaics), the methodology helps to select the most appropriate combination considering the energy performance and economic parameters. The process aims to select solutions that achieve a 50% reduction in the energy demand and/or a significant improvement in the thermal comfort conditions. Comfort conditions using overheating as main indicators is also checked in the methodology. A detailed economic model is part of the methodology giving as a result the following outputs:

- Final investment for owners considering different levels of grants which are energy performance dependent, in Euros/dwelling.
- Monthly owner's payment quote which depends on the funding scheme, in Euros/dwelling.
- Global costs, considering the initial investment, energy savings, replacements, and maintenance costs.

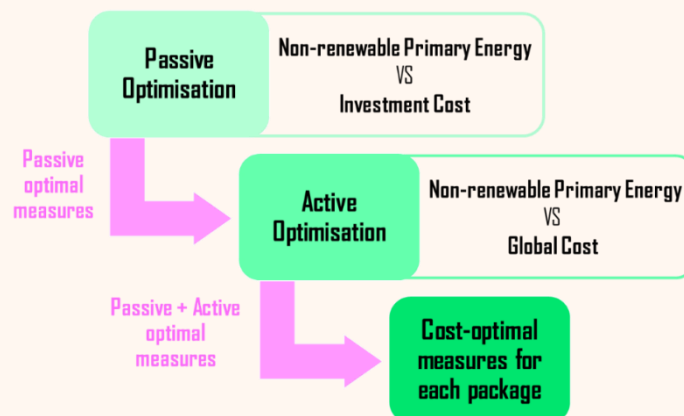

Figure 20. The conceptual scheme adopted for integrated energy design.

What challenge does it solve?

The method aims to support the process of selecting the most appropriate technical solutions considering both energy performance and economic parameters. Getting good estimations of the investment to be done by end-users is a key element for deciding to retrofit the buildings. The detailed economic information is also a key element for the public and private entities which are promoting the large-scale retrofitting process, meaning local public administration, and retrofitting agents, in the framework of Public Private Partnerships.

Who is it for?

Constructors, Architects, Building owners, Municipalities, Policy makers and regulators / authorities. Municipalities, retrofitting agents and/or architects aiming to impulse energy retrofitting in specific districts can have results to assess building owners in the decision process to select technical solutions regarding its economic impact and the energy performance. For each building archetype in the district, a set of conventional and ecological solutions can be compared. Additionally, building owners can have a good estimation of the investment that need to be afforded per dwelling and the potential monthly quote depending on the available financial schemes (Figure 21). All the outputs aim to get informed decisions prior to order a detailed project and budget by a competent technician.

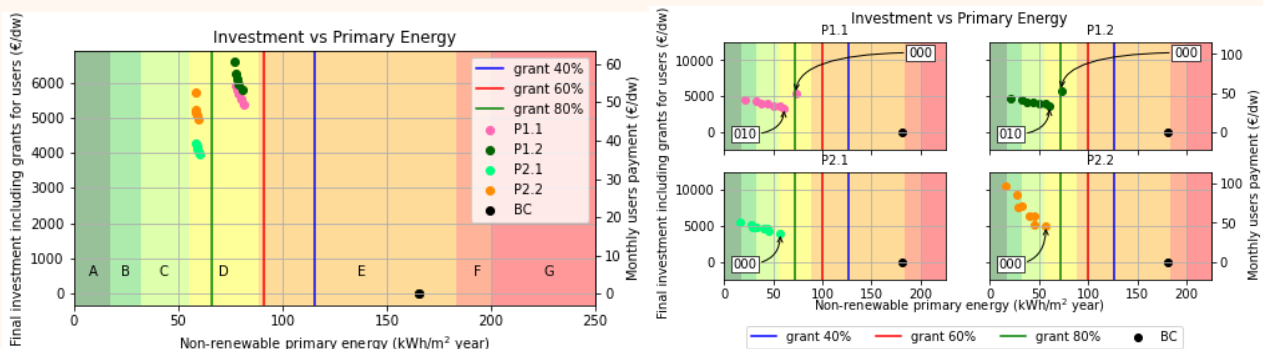

Figure 21. Investment per dwelling vs. non-renewable primary energy use in different renovation scenarios.

How can it be applied and scaled?

The method and its results aim to increase the skills and the knowledge of the key actors in large-scale retrofitting processes. Once adjusted to the building archetypes in a district, the methodology and the tools can be applied to other districts in the same city or in other municipalities.

Demonstrated in Palma de Mallorca, Spain



4.2.2 A CATALOGUE OF INTEGRATED CIRCULAR DESIGN SOLUTIONS

Description

The innovation is a catalogue/database of integrated circular and sustainable solutions for positive and low carbon footprint buildings. It also encompasses a method that aims to collect and systematize the available design measures to respond to the effects of climate change and to reduce greenhouse gas emissions in built environment. The catalogue explores the digital solutions that could support policymakers, architects, urban planners, and technical practitioners in all the life cycle construction stages and the environmental challenges highlighted for the development of Climate Positive Circular Communities (CPCC). The catalogue provides, for each solution, a brief description, the challenges it responds to, the objectives it can achieve, the performance it can guarantee and the benefits, even if not strictly related to the challenges. Each solution refers to one or more case studies defined as best practices. One of the innovative aspects of the catalogue is the presence of information sheets on

products, building systems and technologies, mainly related to enterprises/companies in the local production fabric, which can contribute to the implementation of the proposed solutions (Figure 22).



Figure 22. Example of a sheet for the green roof solution.

What challenge does it solve?

In the current scenario of urbanization and urban population growth, cities need to move towards a healthier and better-quality urban life. The increase of built-up areas and energy demand have been exacerbating the causes and the impacts of climate change. On one hand, cities represent one of the major contributors to climate change and CO₂ emissions; on the other hand, they are vulnerable to the impacts of climate change. Temperature increases and extreme events such as floods, water scarcity and heat waves, are health risks as well as challenges to services and infrastructures. The relationship between cities and climate change has been widely discussed by European and International policies, for example by the SGD 11 and by the European Urban Agenda. Considering the main impacts of climate change in urban areas and the reports on the local situation, five main challenges have been identified: Energy Sustainability (ES), Temperature Regulation (TR), sustainable Water Management (WM), inhabitant’s Health and Wellbeing (HW) and Transition to Circular System (TCS).

Who is it for?

Designers, public administrations, planners, product developers and building companies can use the catalogue as a reference of best practices to be applied on buildings design process in order to foster Positive Energy Districts (PED), Sustainable Plus Energy Neighbourhoods (SPEN) and Zero Emission Neighbourhoods (ZEN) focusing strongly on the interaction and integration between the buildings, the users, and the regional energy, mobility, and ICT systems.

How can it be applied and scaled?

The basis of the innovation is to have a dynamic catalogue, which is a web online version with a freely accessible common part and a specific part where local producers/companies can add their own specific solutions (related to the more general solutions defined within the catalogue itself) and update them, if necessary, in the future. The catalogue can be used also by the other ARV partners because it is structured starting from general to specific purposes, so each challenge could have a national section where local solutions are presented. Future exploitations are mainly in the field of building/urban design and policy making.

Demonstrated in Trento, Italy



4.2.3 TIMBER BASED (NEW) CONSTRUCTION, REFURBISHMENT, AND SUPERELEVATION SCENARIOS

Description

This innovation concerns the development and implementation of two timber-based scenarios for new and existing buildings in the neighbourhood of Piedicastello, Italy, and the close district of Povo. Both scenarios will enhance the use of wood as a circular construction-renovation material combined with forefront sustainable and energy saving technologies, nature-based solutions, and compound performance and comfort monitoring systems. Moreover, the scenarios allow the direct involvement in ARV of design and construction companies from the local timber value chain.

The first scenario (Figure 23) is the construction of a new wooden-based positive energy building located in an area that currently used as a parking lot. The new building has been conceived as a multifunctional hub with integrated services (1 ground floor covered by terrace + 1 underground) which could prove useful to multiple users (i.e., commuters, tourists, etc.) and to the community and residents of Piedicastello.



Figure 23. Final render of ARV timber-based multifunctional hub to be built in the demo area.
Credits: Armalam.

The building will be based on a load-bearing timber frame consisting of timber pillars, glulam beams and wooden floors. The concrete basement floor is planned to be used as a plant and storage service room, and to include an innovative geothermal system developed by the Politecnico of Torino.

The building envelope will consist of prefabricated walls, while the southern side will be covered with innovative prototype walls whose performance will be monitored over the project lifespan: i.e., green wall, ventilated wall, BIPV wall, transparent BIPV wall, cool wall, super-insulated wall. The building will be completed by a smart control system for real-time performance monitoring and management.

The second scenario (Figure 24) is the architectural renovation and energy refurbishment of existing buildings by use of timber. In the ARV project, this scenario is applied on 2 facades of a 3-storey residential building located in the district of Povo, approx. 3 km from Piedicastello. The scenario consists of testing the prefabricated wooden-based panel – called “Renew Wall” (RW) - produced by Fanti Legnami, a local construction company linked to Habitech-DTTN.

“Renew Wall” is a modular system and wooden-based retrofit kit conceived to be easily applied on existing buildings. It is composed by an insulated wood-based panel, which can be integrated with windows, shutters, and a controlled mechanical ventilation machine with heat recovery. The panel can be completed by customizable finishings, thus increasing the architectural and aesthetic appeal. Thanks to the reduced time of works and their limited impact, building occupants can continue to live in their apartment over the renovation. In November 2023, the RW kit has been installed on 2 facades of the Povo demo building. The rest of the building has been renovated through a business-as-usual ETICS kit as part of a complete renovation project (Figure 24). The presence of both these refurbishment technologies will allow to compare and monitor their performance through a sensor system deployed by local research partners.



Figure 24. Before and after the installation of the “Renew Wall” retrofit kit in Povo.

What challenge does it solve?

Both scenarios offer an alternative to as-usual construction and renovation works and address the issue of environmental impacts of buildings. Timber-based interventions allow to exploit the advantages of off-site manufacturing, including the design and delivery of accurate and optimized structural components that only needs to be assembled and installed on site. Compared to business-as-usual solutions, this leads in principle to a reduced and more predictable construction/renovation time, combined with limited impact and inconvenience of works on end-users, such as building occupants, and the surrounding environment (i.e., use of scaffoldings, less noise and dust produced, etc.). Moreover, both scenarios enable to address sustainability in a comprehensive way, combining the well-known features of wood as a construction material (CO₂ sequestration and storage) with optimized energy performance, thermal comfort, nature-based solutions, and RES integration – the latter in relation to the new building.

Furthermore, the new building's structure, which is based on square modules, enables long-term re-usability and possible redesign aspects. Modularity coupled with a flexible layout for the internal space of the building could prove a useful resource for future configurations of the hub and its functions and for adding new parts in both directions and in principle also in elevation.

Who is it for?

Both timber-based scenarios serve multiple target groups. The new building scenario could lead the redevelopment of the parking lot in Piedicastello into a timber-based multifunctional hub. In this sense, it can benefit community and residents of the district, who could use it for leisure, coworking, EV charging, and other activities. At the same time, the new building is beneficial for the regeneration purposes of the Municipality of Trento as well as real-estate representatives who can be inspired by ARV technologies to reshape the closely located "ex Italcementi" brownfield. Built environment professionals can take advantage of the technical results as well. Finally, cutting-edge solutions and construction methods used for the new building scenario are instrumental to the activities of researchers and educational institutions.

These same target groups also benefit from the renovation scenario. In addition, building owners and tenants are among the major beneficiaries, since the retrofit kit is planned to have a positive impact on their daily life, ensuring a better quality of living in residential buildings and apartments

How can it be applied and scaled?

The scalability potential of the new building scenario comes from its modularity, allowing for adaptation to different urban environments, especially in tertiary and commercial areas. The testing of the innovative façades allows to compare different thermal and energy performances and to selected case-by-case the most appropriate solutions depending on the conditions, usage, and context of the installation. Scalability at a district level is also possible thanks to the Piedicastello regeneration plan recently approved by the Municipality of Trento for the northern side of the district, the so-called "Italcementi" brownfield. ARV activities could inform the design and construction of new buildings in that area, partially planned for commercial and tertiary activities.

The refurbishment scenario has also good potential to be scaled at a district level, especially within residential areas including a high number of inefficient private and/or social housing buildings. This leverages offsite manufacturing and prefabrication to produce standardized and optimized wooden renovation kits on a large scale, taking advantage of the abovementioned ease of installation of wooden components. A combination of this sustainable solution with existing fiscal incentives for refurbishment could also encourage the increase of the renovation rate for buildings.

As for the new timber construction scenario, the concept design that was prepared in early 2023 has been deeply developed and refined to reach the executive design phase of the construction project. In parallel, attention is paid to the urban regeneration developments of the "ex Italcementi" area in order to influence its regeneration process in the near future.

The first large-scale installation of the "Renew Wall" system in the Povo district is completed. Scaling it up from a single building to the district level can leverage the One-Stop-Shop approach in Piedicastello to aggregate the demand and supply of sustainable renovation works. Indeed, the residential area of this district, made of medium-rise apartment buildings from the '60s-'70s, can be a potential replication area for larger renovation projects based on prefabricated components.

Demonstrated in Trento, Italy

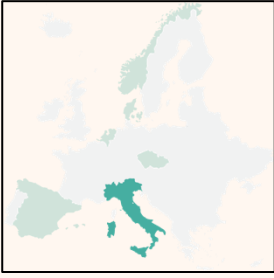

4.2.4 ENERGY TRANSITION – LIVING LAB EDUCATIONAL PLATFORM FOR CITIZENS

Description

The innovation comprises an educational platform for citizens, primarily focusing on youths, with direct relevance to the demo building in the city of Karvina, Czechia. The core of this approach involves a series of seminars conducted with middle and high school students. In the first year, there were four seminars where students primarily learned about innovative energy solutions and acquired fundamental skills for completing their group assignments, which involved designing photovoltaic panels for selected municipal buildings (including the demo building), along with other related solutions like electric car chargers, among others. The second year of seminars is currently in the planning stage and will concentrate on sustainability and circularity within the building industry. The assignment will involve the creative use of reclaimed materials from the demo building (Figure 25).

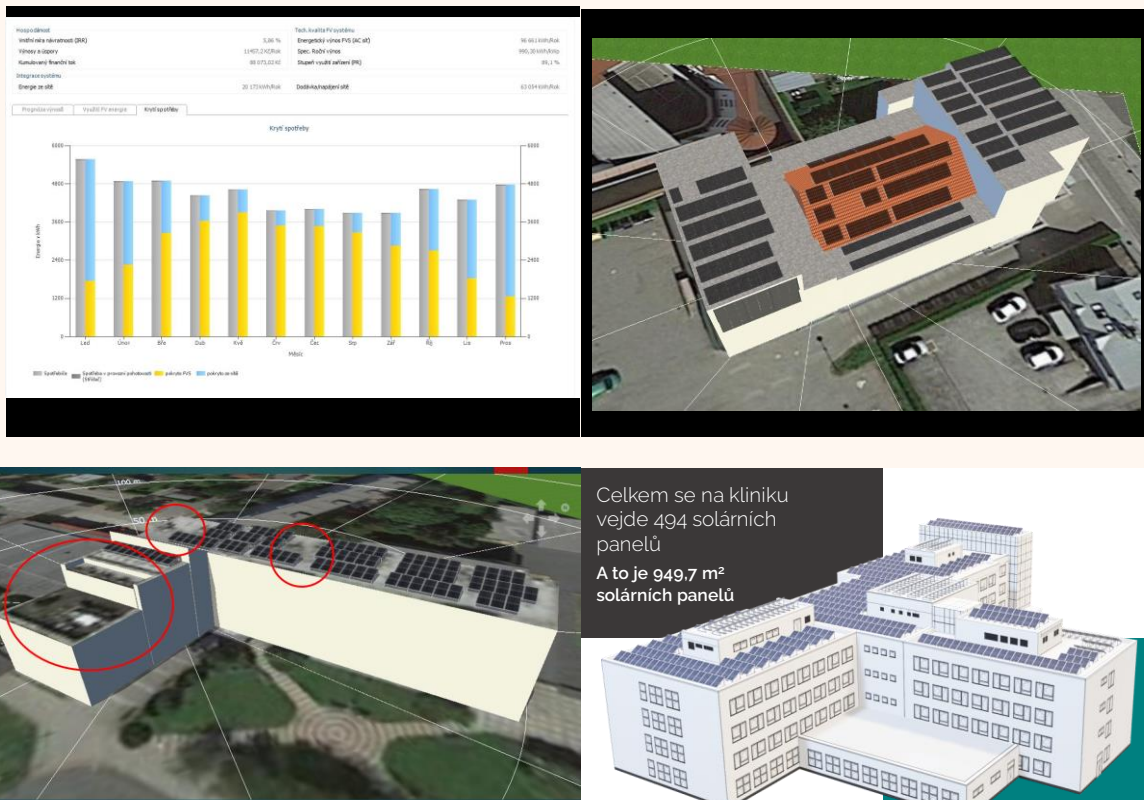

Figure 25. Examples of students' assignments.

What challenge does it solve?

In Karviná, the primary concern that needs attention is the outflow of young people from the region. This trend is partly due to the limited professional prospects available locally. The city of Karviná is

actively seeking more sophisticated approaches to attract and collaborate with young residents, as the city considers this demographic group to be underrepresented in public discussions.

Another vital issue is the support for municipal initiatives and endeavours aimed at reducing greenhouse gas emissions and enhancing the city's environment. These efforts align with the city's goal of achieving climate neutrality by 2050, as outlined in its climate change adaptation strategy of 2017.

Specific Objectives:

1. Engage schools and students in educational activities related to energy, sustainability, and the creation of climate-positive communities. These workshops will feature practical applications of advanced technology.
2. Raise awareness among young people, encouraging them to consider future study and employment opportunities in topics related to climate, sustainability, and community engagement. The aim is to empower them to share this knowledge with their peers and family members and showcase the region as a hub for these themes and associated career prospects. Additionally, the aim is to equip young adults with the tools needed to participate in public debates.
3. Inform and involve various segments of the population in activities and projects that focus on reducing greenhouse gas emissions and enhancing the city's environment, thereby increasing their interest and engagement.



Figure 26. Photo from one of the seminars.

Who is it for?

Municipalities, Research community and educational institutions, Broad public / citizens / non-profit organizations. The educational platform can primarily be managed by the municipality, which can organize it in collaboration with local schools and NGOs. The beneficiaries are the students and possibly also their acquaintances who will acquire new skills and, hopefully, develop an interest in subjects related to sustainability and climate protection.

How can it be applied and scaled?

Skills/education, Citizen engagement. This format can be repeated in the future with the topics that have already been developed (energy and sustainable building industry), new topics can be included in this same format. The assignments of the students can be used in various ways – last year the media got involved and the topic of innovative energy solutions was covered by local TV, another option is to organize an exhibition for the families of the students and broader public to attract attention to these topics.

Demonstrated in Karviná, Czech Republic



4.2.5 MODEL FOR INVOLVEMENT OF TENANTS AND CITIZENS

Description

The innovation is focused on how to engage tenants in energy efficiency improvements driven by a data-approach. It involves a focused tenants-oriented effort in two of the nineteen building blocks in Sønderborg Andelsboligforening (SAB) department 22, i.e., in the demo project in Sønderborg, Denmark. The innovation will investigate how the residents can be motivated to become more aware of their energy consumption and how they can be encouraged to act upon it with an energy savings result as the final outcome. Different tools are tested and selected to communicate energy-saving behaviour to the residents and to find out when the residents are most motivated to carry out energy-saving behaviour.



Figure 27. Photos from resident workshops at Kløver-/Hvedemarken SAB department 22.

What challenge does it solve?

The low level of engagement in energy related topics is a challenge in the housing association, especially because the housing association already produces its own electricity from solar cells and has cheap district heating from the nearest district heating company. Therefore, the motivation of the tenants is not great. In addition, all residents pay for their energy in advance and thereby prepay for their heat. It is calculated once a year in April. This combination makes many residents doubtful as to whether their efforts are having an effect as they don't see the link between the two. This innovation aims to overcome this challenge and create meaningful engagement and clear results.



Figure 28. Brunata Online, an energy data application available for all tenants at SAB.

Who is it for?

The main target group is the residents. They can achieve energy and monetary savings by practicing more energy-efficient behavior in the apartment for their own benefit (comfort and economy), as well as for the larger community of the housing association.

How can it be applied and scaled?

The solutions can be used by a greater number of the housing associations in the municipality and Denmark, as well as the citizens of Sønderborg municipality, nationally and internationally.

Demonstrated in Sønderborg, Denmark

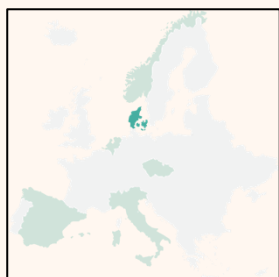

4.2.6 IMPLEMENTATION OF AR/VR TOOLS AND PLATFORM IN DECISION-MAKING PROCESS

Description

Different 3D and/or visualization techniques of Virtual Reality (VR) and/or Augmented Reality (AR) are used during the development of the Oslo and Palma demos to better communicate results of different scenario analyses to different types of stakeholders, to facilitate citizen engagement, and to promote

education and training for sustainability. The development of VR and AR applications are targeted toward several distinct stakeholders (city planners and policy makers) and citizen user group types (e.g., school children, common public, inhabitants and infrastructure users, service personnel).

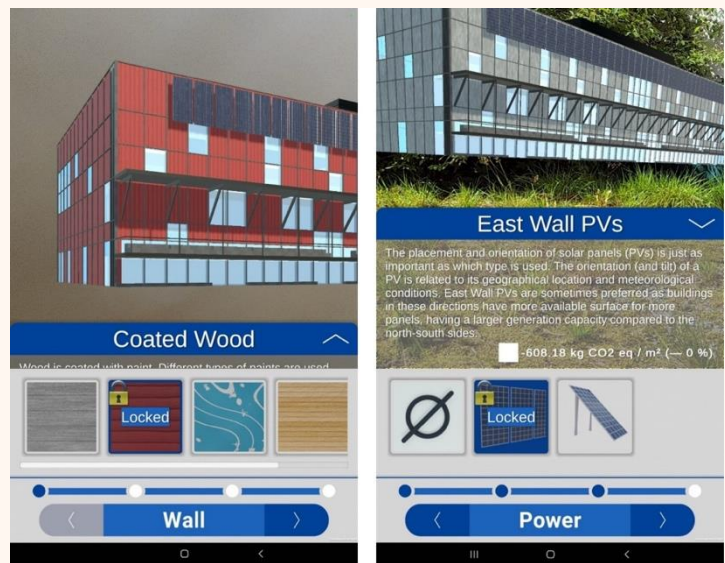

Figure 29. Screenshots of the AR tool showing information about different façade elements/materials.

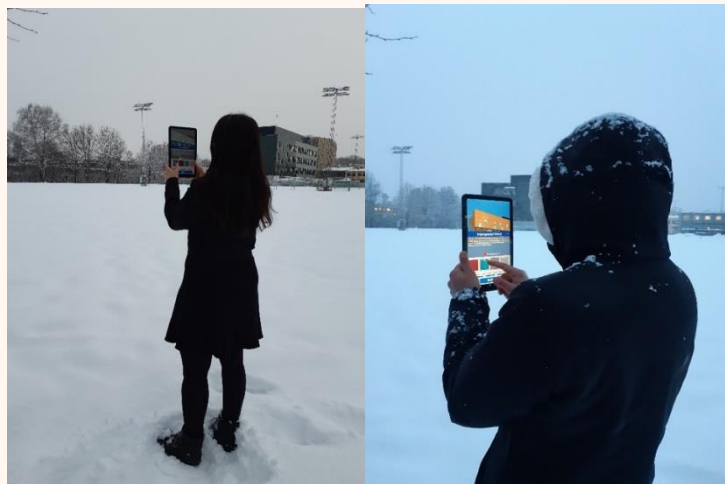

Figure 30. Pilot study participants using the AR tool at the Voldsløkka School, Oslo, Norway.

What challenge does it solve?

The growing development of image-based techniques provides simulation tools to be used for visualization and research purposes. Augmented Reality (AR) and Virtual Reality (VR) are two visualization and presentation tools which provide a greater sense of realism in scenarios one wishes to evaluate. These tools overcome logistical challenges as they can provide real-view (AR) and full-scale visualization (VR) of different scenarios, in which diverse building and urban elements can be easily changed. Research for different disciplines constantly show that users gain a better understanding of the problems when using VR. Indeed, AR and VR tools are promising tools to better communicate and evaluate different solutions to specific problems, as well as to channel users' input and experiences facilitating their active engagement.

Two objectives of the ARV project are to demonstrate a replicable framework for efficient design of CPCC, and to demonstrate community engagement platforms for awareness raising, occupant insight and well-being, and co-creation. AR and VR are relevant tools for contributing to these two specific

objectives. These tools can be used to visualize different solutions in full-scale, immersive, and realistic scenarios that can serve to streamline the evaluation process and decision-taking of stakeholders, and to raise awareness among citizens to engage them in the co-creation of new CPCCs.



Figure 31. Screenshot of the VR tool in Palma, view for Citizen Energy Communities.

Who is it for?

The AR/VR tools are being developed to contribute to decision making. This includes all the stakeholders and interested parties in creating/designing CPCC, for example decision and policy makers, and different citizen groups. Particularly, as the AR/VR tools implemented in the Oslo and Palma demos, these tools will initially be tested with decision-makers working in municipalities (Palma), inhabitants of neighbourhoods (Palma and Oslo), and school students (Palma and Oslo).

How can it be applied and scaled?

AR tool: The development of the AR visualization application is greatly advanced, and a prototype is already finished. The AR tool will be applied for the Oslo demo, more specifically to the Voldsløkka school, in which three building elements will be on focus: wall, glass, and use of photovoltaics (PV). For each of these elements, there are subcategories showing different materials which provide the users with information about the greenhouse gas emissions of each material. This ensures focus on the education of citizens, including school children, on energy-related issues and promote their engagement in the development of CPCC.

VR tool: The development of the VR tool is currently focused on the Palma demo (Llevant Innovation District), specifically on the Neighbourhood Scale Retrofit. There will be 2 display levels: i) the entire framework of the project, in which the target areas of the district will be highlighted allowing a 360° vision with free movement and ii) the environment of each action, in which a street will be selected and modelled in 3D with maximum realism to be used in VR. Both display levels will allow to visualize in full-scale and high realism the defined priority areas of the Llevant Innovation District. This will provide a better understanding of the stakeholders (city planners and policy makers) for decision making.

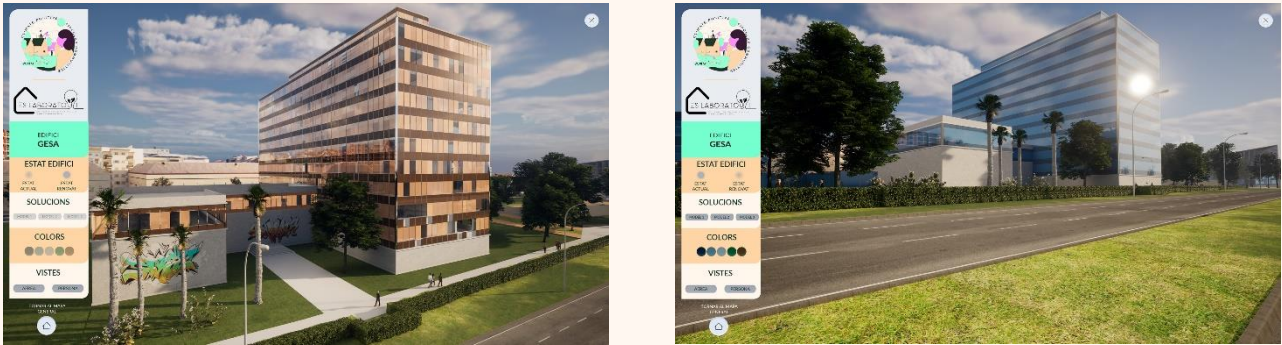
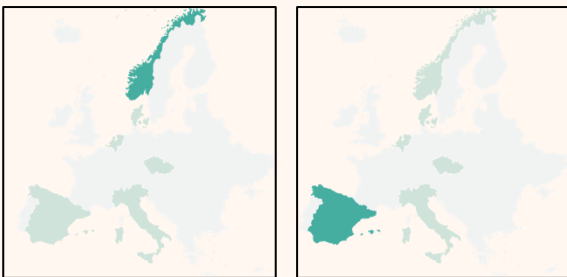

Figure 32. Illustration of the GESA building to be used in a VR scenario for the Palma demo (work in progress).

The AR tool have been tested in a pilot study, in which both experts (people working with architecture and/or sustainability) and lay people (citizens) used the AR application on site, i.e., the Voldsløkka School as part of the Oslo demo (Figures 29 and 30). Their opinions and evaluations of both the app (as technical tool) and the new insights and level of understanding they have had from the app (information about greenhouse gas emissions between different materials) have been evaluated. The findings of the pilot study showed that the AR tool was perceived user-friendly and that it increased the understanding, interest, and engagement of people in sustainable architecture. Also, the high interest was linked to an increased willingness to get more engaged. This suggests that the AR tool can be a useful tool to inform people (both experts and lay people) about energy issues related to architecture, aiming to increase their awareness and interest in climatic topics. Based on these initial findings, the AR tool is planned to be used within the Oslo Living Lab, using it as a tool to increase citizen interest and engagement in CPCC.

For the VR tool, the priority areas for the Llevant Innovation District (Palma demo) are already defined, and the information is collected. The data collected will be used to further develop the VR tool with the 2 display levels mentioned above. The VR model is in good progress and soon to be finished and tested and is expected to support design discussions and meetings with stakeholders in collaboration with the living lab approach to citizen engagement. It has been validated with co-developers and some partial versions and images have been used with selected stakeholders to support taking decisions in the last year.

Demonstrated in Oslo, Norway and Palma de Mallorca, Spain



4.2.7 ES LABORATORI



Description

Es Laboratori is a community development and citizen participation methodology, demo and exhibition space in the area and a hub for citizen engagement towards energy transition in urban spaces and new sustainable technologies. Linked to local energy communities around schools, Es Laboratori will engage a set of training actions and awareness increasing campaigns with special attention to the education of younger generations. Activities will combine use of digital tools, VR visualization, awareness and education campaigns, technologies' showrooms, and open visits. At the moment, there is no physical headquarters in the neighbourhood as it is being renovated, and in the meantime the work is carried out in a decentralised way. Since one of the objectives of a Living Lab (LL) is to take into account the population, networking with the different entities of the district is important to have a presence and to collaborate with them. When the LL moves into the neighbourhood, local connections are already made, and Es Laboratori can offer a physical space to the different initiatives it already supports.



Figure 33. Map of Es Laboratori activities.

What challenge does it solve?

The demonstration project in Palma focuses on large-scale renovation, energy transition and energy communities. The aim of the Living Lab is to involve the local community of the district in the energy renovation. A physical space (Es Laboratori) will be the core of the Living Lab, created as a meeting point for the local community. The aim of the LL is to involve the community on different levels to solve challenges, such as information, awareness and co-creation activities. A special focus is put on involving the most disadvantaged population, so that they are not left behind in the energy transition.

Who is it for?

“Living labs involve users in the innovation process by providing cohesion, offering support, developing competencies and promoting participants” (Almirall and Wareham, 2008¹⁰).

¹⁰ Almirall, E., & Wareham, J. (2008). Living Labs and open innovation: roles and applicability. *The Electronic Journal for Virtual Organizations and Networks*, 10(3), 21-46.

To prioritize actions and strategies in the Palma LL, stakeholders with three roles are described:

1. Population: Should use Es Laboratori as a training and promotion centre for their initiatives, to develop strategies adapted to their context and not to be left behind in the development of the energy transition.
2. Collaborators: Would be all those entities that can support logistically, financially, or by providing training for the initiatives that arise from the population. These can be any public or private entity that is based in or has a stake in the neighbourhood and is interested in supporting the initiatives that arise.
3. Resources: Es Laboratori is the essential resource for development, as it is the link between collaborators and the public and provides the bureaucratic and managerial impetus that only the public administration can give. Apart from this figure, other areas of the public administration and private entities can be key resources for the training and development of the population's initiatives.

How can it be applied and scaled?

Living Lab is an abstract concept that must be adapted to each social and political context. That is why it should be conceived as an open methodology that should be driven by political bodies to take advantage of existing resources, and to improve trust with the population.

Demonstrated in Palma de Mallorca, Spain



4.3 GUIDELINES / INSTRUCTIONS

This section describes the guidelines and instruction innovations developed in the ARV project. Their aim is to explain how a particular activity was done within the ARV project and provide steps that guide users in achieving the goals associated with CPCCs.

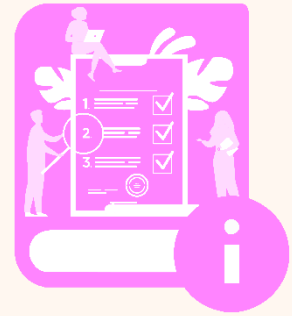

4.3.1 SOCIAL HOUSING RESILIENT DESIGN AGAINST CLIMATE CHANGE

Description

One of the demo projects in Palma de Mallorca, Spain, proposes an organisation of the space which, combined with a constructive proposal, makes possible homes with very low energy consumption, a quality living experience and a building that is integrated into the landscape in an environment with architectural value. The building, with 35 dwellings, is made up of two cores and is accessed via a walkway through the interior courtyard. In this way, all the homes have vital cross ventilation that, together with the captivating use of the double thermal intermediate spaces acting as greenhouses (front and back), solar control and thermal inertia, significantly reduces energy demand whilst maintaining a very high level of comfort.



Figure 34. 35 protected dwellings. Illustration: DataAE

This construction strategy allows for an integration with the environment and historical background of the neighbourhood. The ground floor is raised above street level in order to improve the relationship between the houses on the ground floor and the pedestrians on the street while also allowing natural ventilation into the car park. The homes are distributed continuously along the access walkway, meaning that all the homes have two bays facing the walkway; the entrance and a room. Additionally, the proportions of the vertical solar protection elements help to properly protect the garden façade from the sun. A low-technology construction is proposed, based on load-bearing walls, which helps to drastically reduce the environmental impact of the construction and improve the thermal inertia of the homes, while simultaneously establishing a tectonic dialogue with the surrounding buildings. Almost all of the load-bearing walls are oriented from east to west and are perpendicular with the longest side of the building take advantage of solar gains throughout almost the entire building.

What challenge does it solve?

Building social housing using local low carbon materials, reducing considerably its carbon footprint and minimising energy demand.

Who is it for?

Constructors, Architects, Municipalities, Policy makers and regulators / authorities

How can it be applied and scaled?

Through policy making.

Demonstrated in Palma de Mallorca, Spain



4.3.2 NATURAL AND MECHANICAL VENTILATION CONCEPTS FOR CLIMATE RESPONSIVE BUILDINGS

Description

The purpose of this innovation is to define pros and cons of natural ventilation (NV) techniques in buildings vs. mechanical ones. The innovation is a report on principles, existing standards and guidelines, and perspectives focusing on both energy consumption and indoor well-being. Different techniques of NV are explored and grouped according to the driving forces they exploit. Examples of real buildings using the techniques are also included. Also included are the main purposes NV can be used for and some guidelines to be consulted for developing NV.

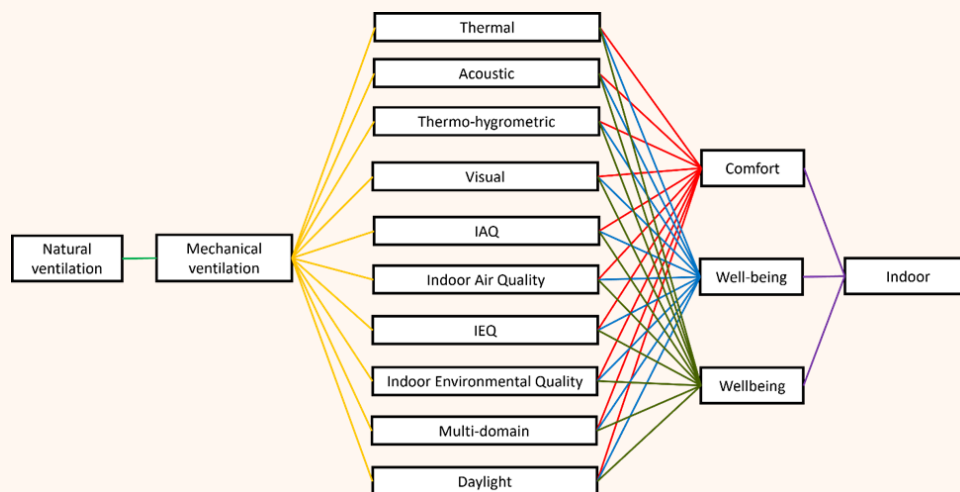

Figure 35. Detailed search string used for the systematic review with AND/OR Boolean operators.

What challenge does it solve?

Recently, buildings are designed considering mainly their energy performance with a massive use of mechanical and building automation systems to control them, often losing the relationship to local climate and the possibility to exploit free and passive solutions. NV can be a good alternative that meets human comfort conditions and increase users' health, as well as allowing to save energy and greenhouse gas emissions to the atmosphere (both locally and globally).

NV relies on natural forces. For this reason, it is considered as one of the main techniques to lower buildings' energy consumption. Moreover, NV was observed to significantly enlarge the acceptable

range of indoor thermal comfort, with respect to mechanical ventilation (MV) systems and this allowed the possibility to accept an increase of indoor temperature when outdoor temperature is higher. Moreover, it was observed that NV also led to benefits related with symptoms associated with Sick Building Syndrome, satisfaction with the environment, productivity, and job satisfaction. For these reasons, NV techniques are worth analysing in the framework of climate responsive and net positive energy buildings.

Who is it for?

Architects, Associations (cooperatives), Municipalities, Research community and educational institutions that can have a range of practical solutions useful to choose the best option for building ventilation depending on the building use and position considering human comfort and energy saving.

How can it be applied and scaled?

The innovation has been shared with the Habitech network in Trento and presented at a Civil Engineering and Building Engineering-Architecture course at the University of Trento, where the students used it for an annual design exercise related to suitability of building ventilation systems.

A possible future exploitation pathway is to continue research activity on NV and MV concerning indoor comfort conditions and energy savings, also by means of extensive monitoring campaign in existing buildings and by the application of the solution included in the deliverable in new buildings design process. The innovation can be uploaded regularly considering scientific progress in the field (if any).

Demonstrated in Trento, Italy

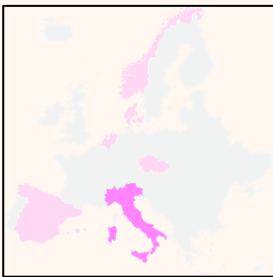

4.3.3 INTEGRATED CIRCULAR AND RESILIENT DESIGN FOR ZERO-EMISSION BUILDING REFURBISHMENT

Description

The merit of this innovation lays in the design process and number of partial, separately reported innovations applied to the demo building in Karvina, Czechia. The design process is carried out in the following steps:

- 1. Research on the status of the building.** The building's technical and operational status will be described, and the tasks for the refurbishment will be defined.
- 2. Identification of the potential.** Based on the possibilities of the current building, the potential of the energy savings, application of renewable resources and measures on the HVAC system are calculated and analysed. The potential of the operation scheme will be identified.
- 3. Preliminary design.** The preliminary design is necessary for improvement of the analyses, feasibility evaluation, and cost calculation. Specific ARV innovations are tested and evaluated in this step.
- 4. Detailed and realized design.** The most detailed design is carried out and realized with the demo building.

5. **Nearly zero energy building** is the result of the process. The building of the healthcare centre will reach the at least nZEB level if no extra measures are applied.
6. **Digital twin** is a crucial tool that will provide support for the design process. The input from the model is used to shape the design from the preliminary stage to the realized building and beyond.
7. **Positive energy building with the potential to reach CPCC Karviná.** Knowledge, experience, and data will be a catalysator of change on a larger scale. The stakeholders will get comprehensive information on how the innovations and technical measures can affect the buildings' behaviour and help to draw the roadmap to CPCC Karviná in the future.

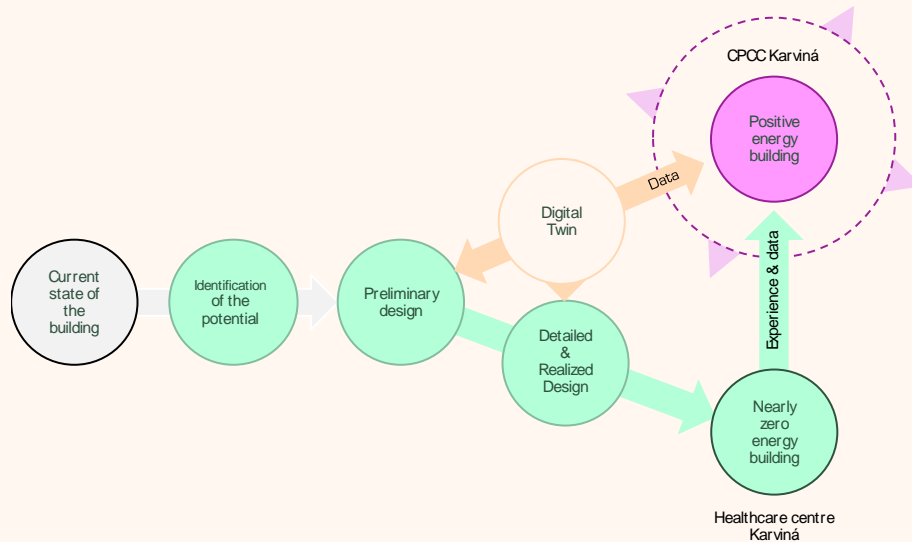

Figure 36. Illustration of the design process.

The use of this method is periodically reported, and its final outcome will be the design guideline, that explains the gained experience and allows to drive the process in the feasible way for further buildings in effective way.



Figure 37. Pictures of the demonstration building in Karviná project site.

What challenge does it solve?

The guideline comes up with the knowledge and experience supporting the decision making in design process of CPCC and nZEB buildings, shows the complex approach and provides support for its replication.

Who is it for?

Constructors, Architects, Building owners, Associations (cooperatives), Municipalities

How can it be applied and scaled?

Open methodology/platform/tool

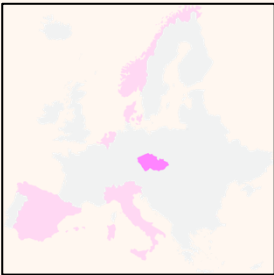
Demonstrated in Karviná, Czech Republic

4.4 SOFTWARE

The following section presents two software innovations achieved in the project so far. They leverage Artificial Intelligence (AI) and other digital technologies to enable more optimal building design and operation, which can lead to better performing buildings, both from an economic and environmental perspective.

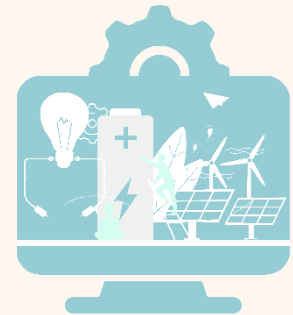

4.4.1 LEANHEAT INTELLIGENT HEATING CONTROL SYSTEM

Description

The Danfoss Leanheat Building is an AI based software and control applied as part of the smart control of the building level heating system. The control of the supply temperature to the building level heating system (radiators and floor heating) is in operation for all 9 building level substations at the SAB department 22 demo building in Sønderborg, Denmark. The installed system upgrades the traditional principle of a static preset relation between the heating system supply temperature and the ambient temperature, the so-called weather compensations principle. The Danfoss Leanheat Building solution includes an adaptive dynamic building model in combination with weather prediction and measured apartment indoor temperatures. In this way, the optimal heating supply temperature can be estimated at a given time without compromising the comfort, taking the passive thermal storage capacity of the building into account, as well as solar radiation, wind, and ambient temperature predictions.

What challenge does it solve?

A qualified setting of the heating supply temperature is critical in respect to reducing uncontrolled heat losses by the building heat distribution system, as well as for reducing the uncontrolled heat emission from the radiators. By applying the Danfoss Leanheat Building AI based control system, the setting is automatically made and optimal all year around. It has proved to reduce the building energy consumption for the heating service, without compromising comfort. Data so far have shown an energy saving of 5-7% for SAB department 22 (Figure 38).

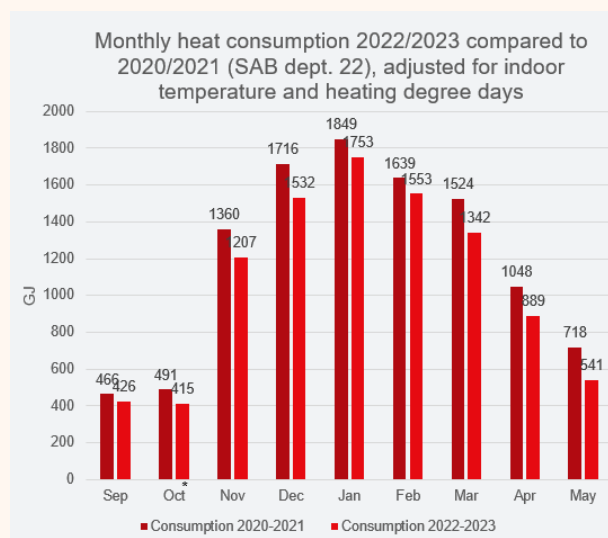

Figure 38. Monthly heat consumption in two time periods.

Who is it for?

Real-estate representatives, building owners, tenants, associations (cooperatives), municipalities, policy makers and regulators/authorities. district heating utilities. Basically, all groups benefit from more energy efficient operation of the buildings.

How can it be applied and scaled?

The concept is available on the market and commercial activities are ongoing. The concept supports the general trend of digitalisation of the district heating system, and a significant market growth is expected.

Demonstrated in Sønderborg, Denmark



4.4.2 DIGITAL DESIGN FOR OPTIMUM LIFE CYCLE PERFORMANCE

Description

In the demo project in Oslo, Norway, BIM and Digital Twins are used to optimize the performance of the building development from the environmental and economic perspective. A comprehensive evaluation of the buildings will be made by considering the lifecycle environmental impact, cost, and energy use, the inclusivity of the local community, the use of indoor and outdoor space, water management, noise and pollution, and aesthetic.

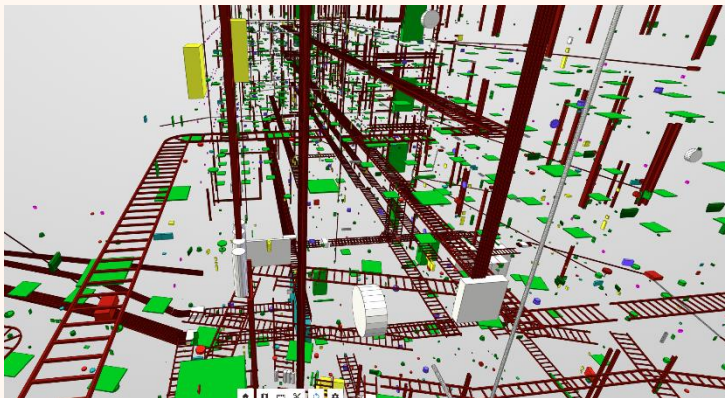
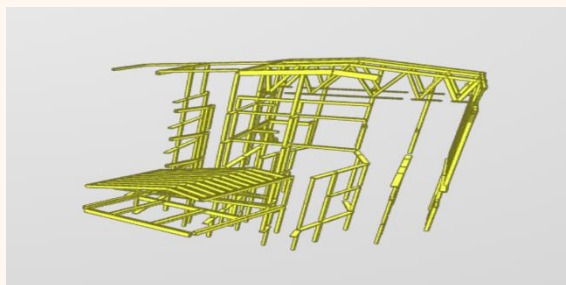
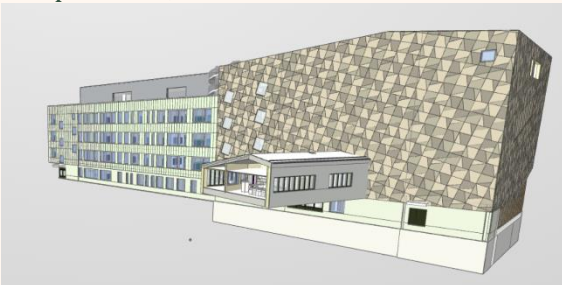

Figures 39. BIM and Virtual Twin visualisations.

What challenge does it solve?

A digital twin can contribute to reducing the mistakes and fails in design and construction of the building and provide better insight of the building's technical and physical information. The latter can result in optimizing the operation, maintenance, and administration of the building in operation phase. Optimizing the construction and operation will result in higher performance and lower environmental and economic impact.

Who is it for?

Constructors, Architects, Building owners, Research community and educational institutions. All the actors in the value chain of a building would benefit from optimizing design, build and operation of the buildings. Architects and constructors can identify and reduce mistakes in design and constructing, owners would be able to optimize the operation and research community can benefit from the knowledge developed by the technology and scale it to mainstream education.

How can it be applied and scaled?

Commercial activities, Integration with already existing technology

Demonstrated in Oslo, Norway

4.5 PROCESS

Here, ARV process innovations are presented. These include innovations, where a series of actions are taken to deliver a specific outcome within an ARV demo. These outcomes are often technical (e.g., emissions reductions from the construction process), but ARV project makes a significant contribution to developing innovative social, educational and community engagement strategies for raising climate awareness and supporting the uptake of CPCCs and sustainable living.

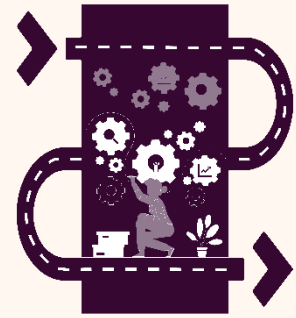

4.5.1 RAISING CLIMATE AWARENESS THROUGH EDUCATION AND LOCAL COMMUNITY ENGAGEMENT

Description

Raising climate awareness among citizens entails a multi-faceted approach, where making use of educational facilities for sustainability teaching of pupils and citizens is particularly pertinent. At Oslo Voldsløkka school, the aim of the engagement activities organized in Living Labs, is raising awareness among secondary school and the cultural school pupils, as well as among their parents and the wider community found in the neighbourhood. The focus of the activities is energy transition and circularity, including solutions regarding energy technologies and building materials. Voldsløkka school will establish a physical demo-space for engaging the pupils into activities of different types, including learning, co-creation and becoming young green ambassadors. The demo-space will be developed in cooperation with the pupils. The activities planned at the school also aim at involving the local community. They will be invited into using the neighbourhood and buildings actively, e.g., through exhibitions, and open events on energy and circularity. In the search for innovative approaches to raising climate awareness among the youth (who are digital natives), AR or VR tools will be actively explored.

What challenge does it solve?

Citizen's perspectives, especially that of young people, are often missing in sustainable neighbourhood transformation. Youths lack the mobility that most adults have in the city, and they often tend to be more limited to the area directly around where they live or go to school. Young people also lack the connections and access to decision makers that many adults and professionals have through work and social engagements. At Voldsløkka, the aim is direct participation strategies towards young people. Young people's perspectives and experiences will be gathered so that they can be actively included in the context of deep energy renovations and the deployment of energy and climate measures by the construction and energy industries. Education, learning, and awareness raising are relevant to create and operate a built environment. The activities will have a strong focus on circularity and how community engagement can contribute to small- and large-scale circular pathways. Raising climate awareness among young people is also a prerequisite for the future of societies. The outcome of engaging with the pupils and the local community is expected to raise awareness about sustainable behaviour, particularly energy efficient solutions. The goal is establishing energy efficient behaviour as part of the community's everyday life.

Who is it for?

The programme and tools developed for the specific activities for raising climate awareness targeting young people and their families, can offer the possibility to be implemented in an educational context in classrooms as well as within the wider community, as methods for teachers. They can also be an

inspiration to other ARV LLs as well as other projects targeting youth, for example within other schools in the Oslo Municipality, though in a modified manner and adapted to the local context.

How can it be applied and scaled?

When asked about what would make the European Year of Youth¹¹ successful, the most stated response (72%) from youths was ‘if decision-makers listened more to the demands of young people and acted on them’. Youth involvement in climate mitigation topics is crucial. Raising climate awareness by creating and operating a climate positive circular community through dialogue and co-creation with the youth in the community and making use of educational facilities and curriculum, represents an exciting opportunity to engage the youth segment in Europe. Living labs as innovation environments will open up for participatory urban planning, in which the focus will be on the collective, allowing local communities to understand the challenges and opportunities related to a specific neighbourhood. This in turn will allow creating active processes together with stakeholders and decision-makers, aiming to achieve mutual learning and engagement that can be used in all future community projects. However, if we are to consider living labs from a strictly ethical point of view, where participation is an essential part of a democratic process, it is important to underline that living labs primarily should be for the good of the community that we are working with. Upscaling is an added advantage and not a prerequisite.

Demonstrated in Oslo, Norway



¹¹ <https://youth.europa.eu/year-of-youth/en>

4.6 MODEL/SYSTEM

In this last report section, one model for energy geostructures is presented. Advanced modelling and systems play a pivotal role in transforming visions into tangible structures. These allow architects, engineers, and project managers to visualise, plan, and optimise every facet of a construction project. From enhancing design accuracy to streamlining collaboration among stakeholders, these systems enable efficiency, precision, and innovation throughout the construction process.



4.6.1 URBAN ENERGY GEOSTRUCTURE IN FORMER 2X25NO-M HIGHWAY TUNNELS AS SEASONAL STORAGE

Description

The concept of assigning a double role, both structural and energetic, to structures in contact with the ground – so-called energy geostructures - has been spreading in the last years for contributing to the production of clean, renewable thermal energy. Thermal activation of tunnels has shown great energy potential and recent full-scale projects have demonstrated the feasibility of this technology. However, so far, applications have been related to new tunnelling projects, whereas possibilities of implementation in the existing heritage of tunnels have not yet been traced.

This innovation is related to the study, design, and testing of a system to retrofit and thermally activate an existing tunnel (in operation or abandoned) for an energy purpose not envisaged originally. The system includes a network of pipes capable of transporting a heat transfer fluid. A prototype of such a system is being investigated by means of preliminary numerical analyses with the final aim to install it in the Piedicastello tunnels within the Trento demo. The tunnels, today abandoned and devoted to an exhibition hall, will be turned into a heat exchanger with the ground and with the internal environment for road de-icing and/or heating and cooling purposes of an adjacent building to test the potential of the identified solution in a realistic operating environment. To this aim, pipes will be fixed at the intrados (1) and inserted in radial holes (2). A preliminary numerical model of solution (1) (see Figure 40) has successfully investigated i) the optimal installation distance from the tunnel mouth, ii) the optimal heat carrier fluid velocity and iii) thermal performance (thermal power and energy produced).

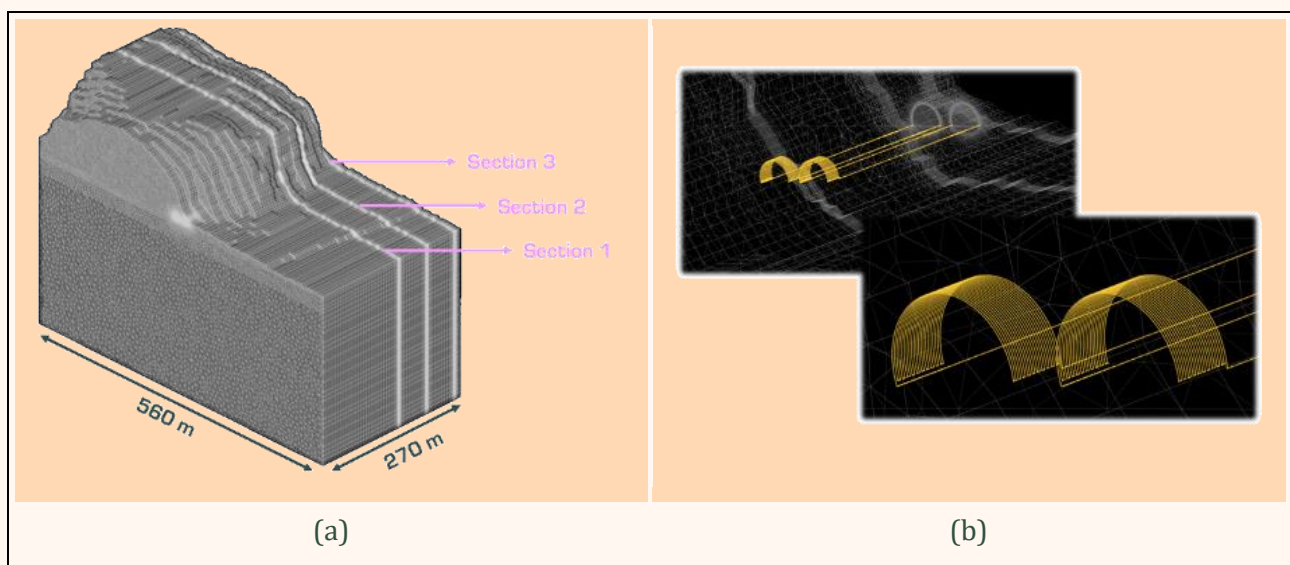

Figure 40. Illustration of (a) the numerical model and (b) close-up view of the heat exchanger system configuration in Section 2 located at an average distance of 65 m from the tunnel mouth.

What challenge does it solve?

Climate change mitigation and adaptation strategies are urgently needed in a world that is becoming extremely vulnerable to the evident signals highlighted by recent extreme weather events. To meet the target of climate neutrality in 2050, the energy transition path needs to follow steps that necessarily include a substantial increase in the use of clean and renewable energy in the sector of heating, cooling, and domestic hot water (HC-DHW). Residential, service and industry sectors combined, their HC-DHW energy share accounts for about 50% of the total primary energy use in 28 EU Member States. Limiting the statistics to the residential sector, the HC-DHW energy supply is covered by coal, oil and natural gas sources for a share of more than 70% in Europe. Not only does fossil fuel consumption contribute to environmental harm, but it also creates an overreliance on interregional supply infrastructures and world economic stability.

The innovation described above represents an efficient technology able to exploit low enthalpy geothermal energy, i.e., a local, renewable energy source with low environmental footprint that would reduce these negative impacts. This energy source provides a massive potential and offers the additional advantage of being pervasively distributed, stable with respect to atmospheric conditions, and cost competitive. In this context, ground source heat pumps (GSHP) technology, based on the thermal coupling between the building and the ground, which is exploited as a heat source or sink to provide thermal energy for the direct HC-DHW use, plays a key role.

The system offers the opportunity to re-use an existing tunnel, built for different reasons (generally transport), also for the exchange of heat with the ground/inner air and, consequently, to heat or cool housing units, providing the buildings' base load, or other potential users, such as stations, as well as for the de-icing of roads and highways, through a sustainable and renewable energy system. It also contributes to the achievement of the minimum percentage thresholds for energy supply from renewable resources to produce domestic hot water, winter and summer air conditioning established by legislation for new buildings and the renovation of civil/building works.

Who is it for?

Constructors, Real-estate representatives, Building owners, Municipalities, Policy makers and regulators / authorities, Research community and educational institutions, Broad public / citizens / non-profit organizations.

How can it be applied and scaled?

The prototype will demonstrate the feasibility of exchanging heat with the surrounding ground through the geostructure, namely the tunnel, for serving a specific building and/or infrastructure. However, metro tunnels and other types of underground structures very often exist in or close to urban centres. Therefore, the technology is optimal for a local harvesting and for widespread distribution of thermal energy at both single space and district scales and could be integrated in low-temperature district heating and cooling networks.

Additionally, aging and decay of existing road and railway tunnels which are getting old all around the world is requiring maintenance and repair works to guarantee the continuation of service in safe conditions. The opportunity offered by the refurbishment can be seized to renovate the tunnels heritage not only from a structural point of view but also under a sustainable standpoint.

The technology potential may be even enhanced by coupling it with other renewable energy-based systems, such as for instance solar collectors. This coupling can lead to interesting applications such as Underground Thermal Energy Storages (UTES). The integration of solar panels for hot water production with the geothermal loops can provide thermal storage abilities to the system and can be used as a thermal source for low-enthalpy energy storage in the ground. This innovative integrated system would allow to buffer differences between thermal supply/demand at a local level, which is particularly attractive due to the inherent asymmetry nature of intermittent renewable energy sources. Tunnels

could thus benefit from a smart and sustainable approach and be retrofitted for transforming them into energy generators having positive impacts in terms of social and economic activities.

Demonstrated in Trento, Italy



5. CONCLUSIONS

The report presents 23 interesting and innovative solutions. Some of the solutions are not innovative on a global scale per se. The innovative part lays in the specific context, environment and framework where the innovations are applied. All innovations presented are aiming at scaling buildings with high performance in energy and major reductions in greenhouse gas emission. Some innovations promote the idea of retrofits to address electricity and fuel waste with better insulation and windows, efficient lighting, and advanced heating.

Overall, all solutions improve the system to enable the transition to Climate Positive Circular Communities. As we look forward, an urban regeneration transformation is undeniably possible. Already, economics favour energy efficiency in buildings and nature-based approaches over linear and fossil fuel-based approaches in many places. A renovation wave shift is underway in Europe, albeit not fast or widespread enough. The speed of transformation is the issue at hand. We must curtail and supplant 19th and 20th century forms of construction and renovation while ensuring that the future of Climate Positive Circular Communities is clean, equitable, and empowering for all.

The ARV Innovation Intelligence for Impact report 2023 has assessed an extensive but not exhaustive set of ARV innovations enabling CPCCs in the ARV demonstration sites, as presented here. The ARV partners continue to add to this compendium as we review and quantify the potential of solutions to stop emissions and/or support sinks in the built environment, as well as broader urban societal transformations that also have climate benefits. In the three years to come the updates of the report will tap upon practices and technologies that are nascent but look to have promise, pending further development and investigation. The ARV Innovation Intelligence for Impact report assessment of solutions will continue to be a living project for the next years. The future report and analysis depend on the availability of critical inputs—namely robust data, reviewed research, and on-site implementation by the ARV partners. The synthesis provided in this report is only as inclusive and robust as the information being synthesized by partners.

The report acknowledges those limitations and encourage research on an increasingly broad solution set, especially innovative solutions emerging from real life experimentations and implemented within the ARV demonstration communities. In the future reports, we will examine other climate solutions. All aim at solving urban regeneration issues that are systemic in nature and challenging to quantify, such as resisting the development of new fossil fuel infrastructure, increasing overall urban density, or reducing consumption through sharing, repair, and re-use. The ARV Innovation Intelligence for Impact report 2023 recognizes the limitations of the scope of our solutions here, too. A broad aperture for solutions is vital, and ARV continues to evolve approaches that support it.

In conclusion, the report strives to be a useful resource for scaling CPCCs and showcasing economic viability and potential into the commercialisation and wide adoption of these solutions.

FUTURE UPDATES

This deliverable will be updated in Month 36 and 48 (December 2024 third version, December 2025 fourth version, respectively) of the ARV project. Each version will present the innovations achieved to date in the ARV project.

REFERENCES

- [1] ARV is a Norwegian word meaning “heritage” or “legacy”. It reflects the emphasis on circularity, a key aspect in reaching the project’s main goal of boosting the building renovation rate in Europe.
- [2] ARV D1.3 Innovation Management Plan (2023), second version V.12 (confidential)
- [3] eMarketplace · ARV (<https://greendeal-arv.eu/emarketplace/>) (Assessed 7 December 2023)
- [4] Patent pending “Modulo solare ibrido fotovoltaico e termico” (I0200930) BR EFF&GIEMME / application number 102023000017145, submission date 10/08/2023
- [5] G. Callegari, E. Merolla, P. Simeone, “Photovoltaic breakthrough in architecture: integration and innovation best practice”, in CONF.ITECH 2022. Technological imagination in the green and digital transition. Conference proceedings, Springer, Switzerland, 2022, ISBN: 978-3-031-29517-1.
- [6] KlimaOslo “2.8 The City of Oslo’s follow-up of the climate strategy” in “Oslo’s Climate Budget 2022 with appendix”, <https://www.klimaoslo.no/collection/oslos-climate-budget-2022> (Assessed on 4th December 2023)
- [7] Norwegian Concrete Association, publication NB 37 <https://betong.net/> and <https://betong.net/wp-content/uploads/Fordrag-Tom-i-Fredvik-Norcem-Pub.nr.-37.pdf> (Assessed on 4th December 2023)
- [8] NEWSCEM - New Supplementary Materials in Cement Production <https://www.ntnu.edu/kt/research/concrete/projects/newsцем> (Assessed on 4th December 2023)
- [9] Zero Carbon Emission Concrete <https://www.ntnu.edu/kt/research/concrete/projects/zerocarбcon> (Assessed on 20th December 2023)
- [10] Almirall, E., & Wareham, J. (2008). Living Labs and open innovation: roles and applicability. The Electronic Journal for Virtual Organizations and Networks, 10(3), 21-46.
- [11] What is the European Year of Youth? https://youth.europa.eu/year-of-youth_en (Assessed on 4th December 2023)

ACKNOWLEDGEMENTS AND DISCLAIMER

This project has received funding from the European Union’s Horizon 2020 research and innovation programme under grant agreement No 101036723.

This deliverable contains information that reflects only the authors’ views, and the European Commission/CINEA is not responsible for any use that may be made of the information it contains.

APPENDIX A – GLOSSARY OF TERMS

Table A.1 Abbreviations used in the report.

Abbreviation	Description	References
AR	Augmented Reality	https://www.gartner.com/en/information-technology/glossary/augmented-reality-ar
BAPV	Building Adapted Photovoltaics	https://en.wikipedia.org/wiki/Building-integrated_photovoltaics
BIM	Building Information Modelling	https://constructible.trimble.com/constructi-on-industry/what-is-bim-building-information-modeling
BIPV	Building Integrated Photovoltaics	https://iea-pvps.org/key-topics/international-definitions-of-bipv/
CPCC	Climate Positive Circular Communities	See ARV Deliverable D2.1 for a detailed definition of CPCC
DH	District heating	https://en.wikipedia.org/wiki/District_heating
DHW	Domestic hot water	https://www.sciencedirect.com/topics/engineering/domestic-hot-water
Dissemination	Making the results of a project public (by any appropriate means other than protecting or exploiting them, e.g., scientific publications)	https://commission.europa.eu/fundingtenders/opportunities/portal/screen/support/glossary
Exploitation	The utilization of results in further research activities other than those covered by the action concerned, or in developing, creating, and marketing a product or process, or in creating and providing a service, or in standardization activities.	https://commission.europa.eu/fundingtenders/opportunities/portal/screen/support/glossary
GHG	Greenhouse gas emissions	https://en.wikipedia.org/wiki/Greenhouse_gas
HVAC	Heating, ventilation, and air conditioning	https://en.wikipedia.org/wiki/Heating,_ventilation,_and_air_conditioning
LL	Living Lab	https://enoll.org/about-us/what-are-living-labs/

NbS	Nature-based solutions	https://research-and-innovation.ec.europa.eu/research-area/environment/nature-based-solutions_en
NZEB	Nearly Zero Energy Buildings	https://energy.ec.europa.eu/topics/energy-efficiency/energy-efficient-buildings/nearly-zero-energy-buildings_en
PEB	Positive Energy Buildings	https://www.sustainableplaces.eu/positive-energy-buildings-definition/
PVT	Photovoltaic Thermal hybrid solar collector	https://en.wikipedia.org/wiki/Photovoltaic_thermal_hybrid_solar_collector
SCM	Supplementary Cementitious Materials	https://www.cement.org/cement-concrete/concrete-materials/supplementary-cementing-materials
VR	Virtual Reality	https://www.gartner.com/en/information-technology/glossary/vr-virtual-reality

APPENDIX B – INNOVATION TYPE DEFINITIONS

Innovation type	Definition	Reference
Database	A large amount of information collected as part of the ARV project and stored in a computer system in such a way that it can be easily looked at, used or changed.	https://www.techtarget.com/searchdatamanagement/definition/database
Guideline/Instruction	A piece of information that explains how an activity was done within the ARV project.	https://dictionary.cambridge.org/dictionary/english/guideline
Method	A particular and systematic way something was done in the ARV project.	https://dictionary.cambridge.org/dictionary/english/method
Model/System	A representation of an object or system developed within the ARV project.	https://en.wikipedia.org/wiki/Model
Process	Series of actions or steps taken to deliver a specific intervention or outcome within an ARV demo.	https://dictionary.cambridge.org/dictionary/english/process
Product/Technical solution	A physical or virtual product or a combination of hardware and software developed within the ARV project.	https://en.wikipedia.org/wiki/Product_(business)
Software	A set of instructions, data or programs used to operate devices and execute specific tasks; applications, scripts and programs that run on a device.	https://www.techtarget.com/searchapparchitecture/definition/software

PARTNER LOGOS

				 ENGINEERING TOMORROW	
				 Institut Balear de l'Habitatge Govern de les Illes Balears	 Shaping Energy for a Sustainable Future
					
					 STERK IN DUURZAME OPLOSSINGEN
					 IL DISTRETTO ENERGIA AMBIENTE
					



ARV