



# D4.5 DESIGN GUIDELINES OF CLIMATE POSITIVE CIRCULAR COMMUNITY IN TRENTO (ITALY)

## WP4 SUSTAINABLE BUILDING (RE) DESIGN

Rossano Albatici, Paolo Baggio, Michela Dalprà, Ivan Giongo, Gianluca Maracchini, Giovanna Massari, Alessandro Prada, Simone Torresin UNITN  
Gianluca Grazieschi, Elena Lucchi, Daniele Vettorato, EURAC  
Marcello Curci, Martina Dell'Antonio, Francesco Gasperi, Andrea Fronk, HABITECH DTTN  
Daniela Bosia, Guido Callegari, Guglielmo Ricciardi, Giuseppe Roccasalva, Lorenzo Savio, Paolo Simeone, POLITO

31.12.2023

## PROJECT INFORMATION

---

<b>Project acronym</b>	ARV <sup>1</sup>
<b>Project title</b>	Climate Positive Circular Communities
<b>Project number</b>	869918
<b>Coordinator</b>	Norwegian University of Science and Technology / Inger Andresen
<b>Website</b>	www.GreenDeal-ARV.eu

## DOCUMENT INFORMATION

---

<b>Deliverable Number and Title</b>	<b>D4.5 Design guidelines of a climate positive circular community in Trento</b>			
<b>Due Month</b>	Month 24 (December 2023)			
<b>Work Package Number and Title</b>	WP 4. Sustainable Building (re) Design			
<b>Task number and Title</b>	Task 4.6 Integrated Circular Design of the Demo Project in Trento			
<b>Dissemination Level</b>	PU = Public			
<b>Date of Delivery</b>	31.12.2023			
<b>Lead Author</b>	Rossano Albatici, University of Trento (UNITN)			
<b>Contributors</b>	Rossano Albatici, Marco Barla, Daniela Bosia, Paolo Bottura, Maria Chiara Brigante, Guido Callegari, Anna Codemo, Michela Dalprà, Antonio Frattari, Alessandra Insana, Gianluca Maracchini, Guglielmo Ricciardi, Lorenzo Savio, Paolo Simeone, Simone Torresin, Luca Zaniboni.			
<b>Reviewers</b>	Mauro Carlino (HABITECH DTTN)			
<b>Status</b>	Final version			
<b>Revision Log</b>	<b>Version</b>	<b>Author</b>	<b>Main changes</b>	<b>Date</b>
	V.01	Mauro Carlino HABITECH DTTN	Accepted with minor changes	15.12.2023
	V.02	Rossano Albatici UNITN	Version for final review	18.12.2023
	V.03	Inger Andresen NTNU, Niki Gaitani NTNU	Final version	29.12.2023

---

<sup>1</sup> ARV is a Norwegian word meaning “heritage” or “legacy”. It reflects the emphasis on circularity, a key aspect in reaching the project’s main goal of boosting the building renovation rate in Europe.

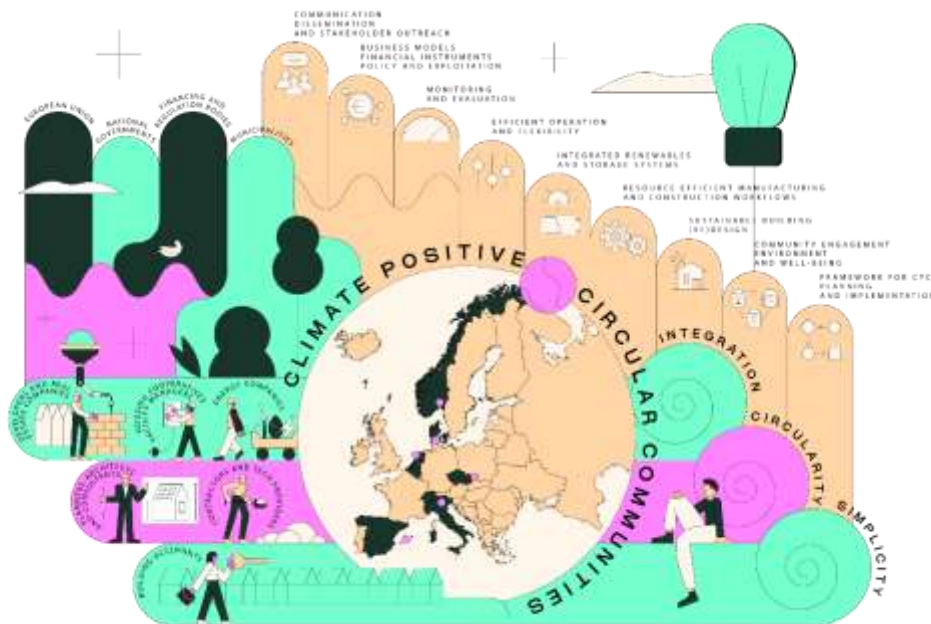
## ABOUT THE ARV PROJECT

The vision of the ARV project is to contribute to speedy and wide scale implementation of Climate Positive Circular Communities (CPCC) where people can thrive and prosper for generations to come. The overall aim is to demonstrate and validate attractive, resilient, and affordable solutions for CPCC that will significantly speed up the deep energy renovations and the deployment of energy and climate measures in the construction and energy industries. To achieve this, the ARV project will employ a novel concept relying on a combination of 3 conceptual pillars, 6 demonstration projects, and 9 thematic focus areas.

**The 3 conceptual pillars** are integration, circularity, and simplicity. **Integration** in ARV means the coupling of people, buildings, and energy systems, through multi-stakeholder co-creation and use of innovative digital tools. **Circularity** in ARV means a systematic way of addressing circular economy through integrated use of Life Cycle Assessment, digital logbooks, and material banks. **Simplicity** in ARV means to make the solutions easy to understand and use for all stakeholders, from manufacturers to end-users.

**The 6 demonstration projects** are urban regeneration projects in 6 locations around Europe. They have been carefully selected to represent the different European climates and contexts, and due to their high ambitions in environmental, social, and economic sustainability. Renovation of social housing and public buildings are specifically focused. Together, they will demonstrate more than 50 innovations in more than 150,000 m<sup>2</sup> of buildings.

**The 9 thematic focus areas** are 1) Effective planning and implementation of CPCCs, 2) Enhancing citizen engagement, environment, and well-being, 3) Sustainable building re(design), 4) Resource efficient manufacturing and construction workflows, 5) Smart integration of renewables and storage systems, 6) Effective management of energy and flexibility, 7) Continuous monitoring and evaluation, 8) New business models and financial mechanisms, policy instruments and exploitation, and 9) Effective communication, dissemination, and stakeholder outreach.



The ARV project is an Innovation Action that has received funding under the Green Deal Call LC-GD-4-1-2020 - Building and renovating in an energy and resource efficient way. The project started in January 2022 and has a project period of 4 years, until December 2025. The project is coordinated by the Norwegian University of Science and Technology and involves 35 partners from 8 different European Countries.

## EXECUTIVE SUMMARY

---

Built environment must make a major contribution to the transformation of the EU towards carbon-neutrality and it is widely accepted that acting at neighbourhood or district scale is one of the chances to face climate emergency.

The vision of the ARV project is to contribute to speedy wide scale implementation of Climate Positive Circular Communities (CPCCs) where people can thrive and prosper for generations to come. The CPCC concept focuses strongly on the interaction and integration between new and regenerated buildings, users, and regional energy, mobility, and ICT systems by means of providing attractive, resilient, and affordable solutions and emphasising circularity, social and architectural quality as key aspects. Passive building design/biomatic design have long traditions across Europe. Still, the potential of this powerful approach is not being fully harvested in current practice. This is despite the fact that modern passive design has an even higher potential, by using new knowledge of environmental issues.

The intent of the ARV project is to develop and demonstrate **a new paradigm of 'integrated circular design of CPCCs'**, by taking a multidisciplinary approach to (re)design buildings with maximize energy efficiency, minimize life cycle greenhouse gas emission and costs, optimizing occupant well-being and ensure high architectural qualities. This will be accomplished by using modern digital tools (BIM, Digital Twins) in a multistakeholder cooperation.

The main objective of this document is to provide the second version of the design guidelines of Climate Positive Circular Communities (CPCC) with focus on the demo project in Trento, Italy. The document collects the results of the key actions carried out for the **Destra Adige - Piedicastello** demonstration project in Italy that covers both, new construction, and renovation of existing buildings.



The **current structure of the document** consists of the following sections. After the introduction (chapter 1), the executive summary (chapter 2), the general vision and goals (chapter 3), the chapter 4 provides the urban area presentation. In the first part of this chapter, it gives a brief history of the site, an overview of its current state and the functions expected by the municipality plan of Trento city; the second part presents the design plan in terms of general analysis, stakeholder engagement, goals, strategies, and solutions. Chapter 4 is followed by two chapters with the same structure dedicated to the design of new construction (chapter 5) and the design of existing building refurbishment (chapter 6). The design process is described in its main stages, which are the Early Concept Design (ECD), the Development Design (DD), and the Detailed Design (DeD) with regard to procedure and stakeholders involved, architectural, environmental, social, economic goal, strategies and solutions pursued. A summary and some reflections on the design replicability and transferability in the urban area close the chapters. The innovations in the demonstration project are described in chapter 7, while the lessons learned during the urban planning and the design stages are summarizing in chapter 8. The document ends with the annexes (chapter 9) and Acknowledgements.

This document will be revised and supplemented annually during the course of the ARV project.



## TABLE OF CONTENTS

<b>1. Introduction.....</b>	<b>7</b>
<b>2. Executive summary of the project Destra Adige - Piedicastello, Trento, Italy .....</b>	<b>9</b>
<b>3. Vision and goals.....</b>	<b>12</b>
3.1. Vision	12
3.2. Goals	12
<b>4. Urban area presentation .....</b>	<b>13</b>
4.1 General overview of the Piedicastello area	13
4.1.1 Partitioning of the area into four sub-areas .....	13
4.1.2 History of the site .....	14
4.1.3 Current status of the site.....	16
4.1.4 Expected functions by the municipal plan.....	18
4.2 Design plan	22
4.2.1 Analysis requirements and potentialities/opportunities .....	22
4.2.2 Procedure and stakeholder involved .....	26
4.2.3 Architectural, environmental, social and economic goals .....	28
4.2.4 Strategies and solutions .....	28
<b>5. Design of the new construction .....</b>	<b>30</b>
5.1 Early Concept design	30
5.1.1 Procedure and stakeholders involved.....	30
5.1.2 Architectural, environmental, social, economic goals (What, why, who, how) .....	34
5.1.3 Strategies and solutions (2023) .....	34
5.2 Design development	45
5.2.1 Procedure and stakeholders involved.....	45
5.2.2 Architectural, environmental, social, economic goals (What, why, who, how) .....	46
5.2.3 Strategies and solutions .....	46
5.3 Detailed design	54
5.3.1 Procedure and stakeholders involved.....	54
5.3.2 Architectural, environmental, social, economic goals (What, why, who, how) .....	54
5.3.3 Strategies and solutions .....	54
5.4 Summary	54
5.4.1 Architectural qualities.....	54
5.4.2 Social qualities .....	54
5.4.3 Environmental sustainability .....	54
5.4.4 Economic framework.....	54
5.5 Design replicability and transferability in the urban area	54
5.5.1 Opportunities.....	54
5.5.2 Challenges .....	54
5.5.3 Strategies and solutions .....	54
<b>6. Design of existing buildings refurbishment.....</b>	<b>55</b>
6.1 Early Concept design	56
6.1.1 Procedure and stakeholders involved.....	57
6.1.2 Architectural, environmental, social, economic goals (What, why, who, how) .....	58
6.1.3 Strategies and solutions .....	58
6.2 Design development	63
6.2.1 Procedure and stakeholders involved.....	63
6.2.2 Architectural, environmental, social, economic goals (What, why, who, how) .....	63
6.2.3 Strategies and solutions .....	63
6.3 Detailed design	68

6.3.1 Procedure and stakeholders involved.....	68
6.3.2 Architectural, environmental, social, economic goals (What, why, who, how) .....	68
6.3.3 Strategies and solutions .....	68
6.4 Benchmark the solution against ARV KPIs .....	73
6.4.1 Total primary energy .....	73
6.4.2 Life cycle assessment and life cycle cost .....	73
6.4.3 Indoor environmental quality .....	77
6.4.3 noise during retrofitting.....	77
6.5 Summary .....	78
6.5.1 Architectural qualities.....	78
6.5.2 Social qualities .....	78
6.5.3 Environmental sustainability .....	78
6.5.4 Economic framework.....	78
6.6 Design replicability and transferability in the urban area .....	78
6.6.1 Opportunities.....	78
6.6.2 Challenges .....	78
6.6.3 Strategies and solutions .....	78
<b>7. Innovations in the Destra Adige - Piedicastello demo.....</b>	<b>79</b>
<b>8. Best design practices and challenges .....</b>	<b>87</b>
<b>9. Annexes .....</b>	<b>88</b>
9.1 Catalogue of integrated circular design solutions .....	89
9.2 Natural and mechanical ventilation concepts .....	236
9.3 Others .....	296
<b>Conclusion and future updates.....</b>	<b>477</b>
<b>References.....</b>	<b>478</b>
<b>Glossary of terms .....</b>	<b>480</b>
<b>Acknowledgements and disclaimer .....</b>	<b>481</b>
<b>Partner logos.....</b>	<b>482</b>

# 1. INTRODUCTION

---

Cities play a key role in achieving climate neutrality by 2050, the goal of the European Green Deal. They take up only 4% of the EU's land area, but they are home to 75% of EU citizens. Furthermore, cities consume over 65% of the world's energy and account for more than 70% of global CO<sub>2</sub> emissions. Since climate mitigation is heavily dependent on urban action, we need to support cities in accelerating their green and digital transformation [1]. In particular, European cities can substantially contribute to the Green Deal targets [2]. These will be developed as Climate Positive Circular Communities (CPCCs), which is a concept that rests on three main pillars: 1) circular economy, 2) integration of people, buildings, and energy systems, and 3) simplicity – achieved by means of digitalization and industrialization.

A Climate Positive Circular Community (CPCC) is an urban area where people can thrive and prosper for generations to come. The CPCC concept focuses strongly on the **interaction and integration between new and regenerated buildings, users and regional energy, mobility, and ICT systems by means of providing attractive, resilient, and affordable solutions** and emphasizing **circularity, social and architectural quality as key aspects**.

**WP4** of the ARV project deals with the **(re) design** of new and retrofitting of existing buildings as zero-emission positive energy buildings in sustainable Climate Positive Circular Communities (CPCCs). The main objectives are: (i) to reduce the embodied energy and emissions; (ii) to increase the energy efficiency; and (iii) to match sustainability with aesthetics and quality of life, by integrated circular design processes.

The activities in WP4 are divided into six main tasks that address design strategies of buildings integrated in CPCCs. This document refers on the **task 4.6** called 'Integrated Circular Design of Demo Project in Trento'.

The **ARV integrated circular design** applied on the case study in Trento includes adaptation to local climate conditions, deep renovation with minimum disruption for buildings occupants, significant reduction of CO<sub>2</sub> emissions, high energy efficiency with active/passive solutions, high focus on circularity i.e. reduce, re-use & recycle of materials, elements & modules, add value, and resource & energy efficient integration of PVs i.e. BIPV & BAPV, while satisfying occupant well-being and architectural considerations. The design considerations addressed the scalability, flexibility, durability, maintainability, safety, and aesthetics of the buildings. The buildings and the neighborhood of the case study were embedded in the spatial, economic, technical, environmental, regulatory, and social context of the demo site.

## Why do we need the Guidelines?

History has shown that (re)design can play a crucial role in improving our buildings, neighbourhoods, cities, and the quality of life of its residents. Today, architects, engineers, urban planners can help address one of the most urgent and widespread challenges of our time, ecological transition, and its related declinations, by implementing the strategies contained in these *Guidelines*. With the dissemination of the *Guidelines*, the city of Trento signals its commitment to become a CPCC.

## Who will use the Guidelines?

The *Guidelines* address all who have a role in the design and construction of the built environment. This encompasses professional designers (such as urban planners, engineers and architects); building owners and private developers; contractors, suppliers of materials, components and services; energy companies and building managers; users including city residents and building occupants and research/educational institutes.

The *Guidelines* are intended to aid and encourage collaboration among different design professionals and stakeholders in promoting a new paradigm of 'integrated circular design of CPCCs'. Although the

*Guidelines* are written with the city of Trento as the focus, the strategies contained here can also be applied to other cities and communities. The *Guidelines* will also assist architectural, planning, and design educators seeking to incorporate key design factors promoting CPCCs into student projects and curricula.

**How should the Guidelines be used?**

Readers are encouraged to read the *Guidelines* in their entirety, to get a clear understanding of the contents and the design process pursued. The Guidelines are also intended to provide a possible contribution that could stimulate reflections for possible additions and/or amendments to existing regulatory documents.

## 2. EXECUTIVE SUMMARY OF THE PROJECT DESTRA ADIGE - PIEDICASTELLO, TRENTO, ITALY

---

The Italian demo case is called *Piedicastello Destra Adige* and located in the Northern Italian city of Trento. The demo case consists of four areas:

**Area 1**, the former Italcementi industrial site, will now be a replication area of area 4 testbed. In the coming years, Area 1 will host an entirely new mixed-use district of Trento, containing residential and tertiary buildings, as well as the new student's residence of the University of Trento. The aim is to develop the district as self-sufficient, by also exploiting on site geothermal potential and optimizing the urban morphology of the new building blocks (i.e., orientation, size, position etc. for RES production to power the geothermal heat pumps).

**Area 2** is an urbanization from the 50s–70s. Most of the buildings are close to or have already reached the end of their life cycle. The area was developed with a strong focus on social housing and is still largely owned by the Trentino Institute for Social Housing (ITEA). These residences are to be renovated by using standardized prefabricated timber-based façade elements, implementing the so-called “One-Stop-Shop” which provides technical support at all stages of design and realization. Through the OSS private owners of the area will be invited to associate themselves in the redevelopment process, thus guaranteeing a high degree of replicability also for other areas of Trento. The OSS approach is complemented by a renovation demo, which has been moved from Piedicastello Area 2 to the close city district of Povo. The demo consists of a medium-rise residential building: in the framework of ARV, its refurbishment entails the use of “Renew Wall”, an innovative timber-based façade system for energy and architecture improvements.

**Area 3** includes the former Piedicastello highway tunnels encompassing two 250-m holes in the Dos Trento Mountain which are currently used as an art and exhibition gallery. This geostructure is intended to supply and store energy for the surroundings of the tunnels in Piedicastello, i.e., Area 1 or Area 2.

**Area 4** which is currently used as a parking lot (the “ex Zuffo” car park), will be redeveloped with a service HUB for the district and the city. It will connect commuter flows to commercial services and will host an energy storage system, following the V2G approach, simultaneously promoting the market penetration of electric mobility. Additionally, Area 4 will now host a new test building, planned as a multi-functional hub with integrated services. Mainly based on a timber load-bearing frame, the building includes innovative façade elements on its southern side, whose performance will be monitored over the project lifespan.

This demonstration project includes the construction of a new building that demonstrates the ambition of positive energy performance and the innovative energy refurbishment of an existing building with timber-based facades.

The demo case focuses on:

- development of a catalogue of Integrated Circular Design Solutions (ICDSs);
- study the natural and mechanical ventilation concept for climate responsive buildings;
- application of a circular economy-based design process;
- integration the Nature Based Solutions (NBSs);
- development and demonstration of new perspectives and scenarios for timber construction in urban regeneration;
- informing Industry 4.0 via digital surveys;
- improving comfort (psychological, physiological) of the building occupants;
- co-creating one-stop-shop enabling diffusion of design technology: replicability of solutions;



- integrating heat pumps for heating and cooling (connection to NSGE – tunnels, foundations, roads) or integrate passive heating systems integration in buildings envelopes; integrate active/passive systems via Building Automation Systems;
- analyse of existing models for scenarios elaboration to inform hybrid Energy/Nature-based solutions on building/urban surfaces;
- use of innovative materials (new and waste/by-products);
- architectural and aesthetic integration of BIPV/BAPV solutions, integration between PV, Solar Thermal and CMV systems.



*Figure 1. Map showing the four ares of the demo project in Trento (Source: Google Earth).*

## 3. VISION AND GOALS

---

### 3.1. VISION

---

Cities change and transform. Cities are key drivers of ecological transition and sustainability is most efficient at city level [3].

A CPCC can be an urban area, a city district, and consists of several interconnected buildings with associated infrastructure like grids and technologies for generation, storage, and exchange of electricity and heat.

The vision is to contribute to the transformation process of the Destra Adige - Piedicastello district in order to become a CPCC designing and demonstrating integrated circular buildings for high energy performance, low emissions, low cost, good indoor climate, and high architectural quality (that is WP4 of the ARV project), and with the support and interaction of the other WPs.

The overall aim is to demonstrate and validate attractive, resilient, integrated and affordable solutions for the case study that will significantly speed up the deep energy renovations and the deployment of energy and climate measures in the construction and energy industries.

The challenge is addressed employing methods of integrated design and construction, using digital tools, life cycle analysis to minimize the embodied energy and emissions, and applying the principles of circular economy for the (re) design processes, focusing on local bio-based materials, reuse, recycling, durability, resiliency to achieve reduction in embodied emissions needs compared to current country building standards.

### 3.2. GOALS

---

The GOALS of the planning and design phases of the demo project are:

- To (re) design buildings with an **environmental focus** to reduce negative impacts on the environment, and the health and comfort of building occupants as well as increase building resiliency. Improving the energy performance of existing buildings is important to increasing our energy independence. Designing positive or net zero energy buildings is one way to significantly reduce our dependence on fossil fuel-derived energy. Utilizing sustainable materials can also help to minimize environmental impacts such as global warming, resource depletion, and toxicity.
- To (re) design buildings with an **architectural focus** for the urban regeneration based on the use of timber. The intent is to implement integrated tools and technologies towards urban and building transformation processes with results that are simple but aesthetically pleasing and meet the needs and enhance the quality of the experience beyond functionality.
- To (re) design buildings with a **social focus** to foster personal relationships and give new goals to these 'new buildings' enabling communities to identify with shared values. Assessing the benefits of the project for the community and adopting ways of encouraging citizen and stakeholder participation and ensuring that their opinions are heard at the various stages of the project is therefore crucial [4].
- To (re) design buildings with an **economic focus** to achieve a changing process to reduce the costs and revive the local economy. Developing replicable and scalable building solutions for new construction and renovation contributes to an economic growth. Economic growth should bring prosperity and a better quality of life for all of us.



## 4. URBAN AREA PRESENTATION

---

### 4.1 GENERAL OVERVIEW OF THE PIEDICASTELLO AREA

---

Trento is a city in the North-East of Italy, the capital of the Autonomous Province of Trento (PAT). With approximately 120.000 inhabitants, in 2022, it ranks 37th among the Italian cities with more than 60.000 inhabitants by resident population [5].

The area chosen for the Italian demo case is the Destra Adige - Piedicastello district. It is an area of the city that is primarily flat, bordered to the west and north by Monte Bondone and Doss Trento, and to the east by the Adige River. Together with the historic centre of Trento, it is part of administrative district number 12 of the city of Trento. The connection with the central part of the city is currently provided by the San Lorenzo bridge.

The name Piedicastello presumably originates from its location at the base of Doss Trento, the small mountain originally called 'Verruca castellum' located near the Adige River that in the past provided shelter to local residents in case of attack by foreign populations [6].

#### 4.1.1 PARTITIONING OF THE AREA INTO FOUR SUB-AREAS

Destra Adige - Piedicastello district is an urbanised area characterised by an old village, an early 20th century working-class settlement, more fragmented contemporary residential units, a large empty former industrial site, a church, sites of archaeological and naturalistic interest, and two former road tunnels called 'Gallerie di Piedicastello' converted into an exhibition space.

Destra Adige - Piedicastello area is primarily made up of public property or property belonging to public institutions (such as State Property, the Autonomous Province of Trento (PAT), the Municipality of Trento, Patrimonio del Trentino SpA, etc.), and to a lesser extent, private subject property.

The district proves to be of strategic importance for the aims of the ARV project in relation also to the "Destra Adige - Piedicastello" Master Plan, which the Municipality of Trento recently approved for the district's redevelopment in accordance with sustainable development principles on the social, economic, and environmental perspectives.

The Trento demo case consists of four areas. See SHEET - **PARTITIONING OF THE AREA** in the **Annex 9.3.1**.

**Area 1:** the "ex Italcementi" industrial site will host a completely new Trento mixed-use district with residential and tertiary buildings. The objective is to make the new district self-sufficient, exploiting the area's very high geothermal potential for the supply of geothermal heat pumps and its south-east orientation for photovoltaic production.

**Area 2:** an urbanised area from the 1950s-1970s. Most of the buildings are near or have already reached the end of their life cycle. The area was developed with a strong focus on social housing and is largely still owned by the Istituto Trentino Edilizia Abitativa Spa (ITEA). These buildings must be renovated and refurbished. To do so, the purpose is to use standardised and prefabricated wood-based façade elements, implementing the so-called "One-Stop-Shop" that provides technical support in all phases of design and construction; private owners are also invited to join in the renovation process, thus ensuring a high degree of replicability for other areas of Trento.

**Area 3:** this includes the ex Piedicastello road tunnels, consisting of two 300 m holes in the Doss Trento, that are currently used as an art and exhibition gallery. This geostructure is intended to provide and store energy for the new city district in areas 1 and 2.

**Area 4:** it is a large car park that will be upgraded with a charging HUB station for recharging electric cars, serving those who cannot do so at home. It will connect commuters to commercial services and host an energy storage system, following the V2G approach (two-way bi-directional charging technology that allows electric vehicles to return energy to the grid), while simultaneously fostering market penetration of electric mobility.

#### 4.1.2 HISTORY OF THE SITE

Piedicastello, located on the right side of the Adige River at the bottom of Doss Trento and on the way to the Giudicarie Valleys and to Brescia, was the first human settlement of the city of Trento. Archaeological findings attest to the presence of ancient human cultures in this area, consisting of populations of Rhaetian and Gallic origin.

Later on, the Roman occupation changed the situation: the Romans founded the city on the left bank of the Adige because it was protected by the river and crossed by the Via Claudia Augusta Padana. The local population, feeling safer on the other side of the river, abandoned Doss Trento to settle within the Roman walls.

During the Barbarian invasions, the Doss Trento once again welcomed the population of the city, who returned to take refuge there, abandoning the Roman city, which suffered a contraction in its development. The defences on Doss Trento were strengthened and the village of Piedicastello expanded at its foot, with the need to build a place to carry out religious practices [7].

In mediaeval times, with the subsequent development of the city on the left side of the Adige River, Piedicastello remained outside the walls, isolated, relegated to a ghetto and subject to fires and looting. During the period of the Council of Trent (1545-1563), Piedicastello became the place used to gather the troublesome population, i.e. those who could represent a public order problem for the safety of the Church fathers. Of particular note is the fire in 1703 when the village was bombarded by the French General Louis Joseph of Bourbon-Vendôme during the War of the Spanish Succession.

The area experienced a new commercial development after 1845 as a result of the construction of a new road leading to the Giudicarie valleys via the "Bus de Vela"; a distinctive feature of the area is the fountain in the middle of the Piedicastello square, which was used to rehydrate the cattle of passing merchants [8].

Inhabited by a population of boatmen, sandmen, flint mongers, innkeepers, washerwomen and carters, Piedicastello was one of the first working-class neighbourhoods of the 19th century and the site of early industrialization. Given the massive growth in the building industry at the beginning of the 19th century and the lack of local cement production, the entrepreneur Domenico Frizzera started the construction of a company for the production of bricks and Portland cement at S.Nicolò di Piedicastello. His activities were confined to timber trading up until the 1880s, but in the years that followed, inh started to include brick and lime trading and manufacturing, thus necessitating the construction of a brand-new industrial facility. The cement factory was the first large industrial plant in the city of Trento. The business changed from being a private company to the "Prima fabbrica trentina di Cemento Portland Domenico Frizzera" corporation in 1911. As the First World War broke out, production was interrupted and, after the death of the owner in 1919, the company was subsequently bought by the 'Società italiana e società anonima calci e cementi' of Bergamo and, from 1927, named 'Italcementi'.

The company expanded further until it reached maximum employment in 1939 with 240 workers. However, as the cement factory expanded, the population of Piedicastello began to complain about the air being full of soot, brick and cement dust and frequent mine fires.

The Trento municipality thus decided to implement measures such as the application of filtering systems, but dust continued to surround the district. The cement factory remained active until the 1970s, then increasingly reduced production until it stopped completely in the 1990s. Following the



closing of the facility, the area was demolished and partially reclaimed in 2013. Today, only two chimneys remain as evidence of the industrial past.

During the construction of the cement plant, the need to build houses for workers and employees emerged. Some areas to the north of the industrial site were proposed and housing projects were presented, leading to the construction of workers' houses in Via Verruca and Via Papiria. The municipality of Trento looked at the residential area of the Lanerossi industrial plant in Schio (VI) and designed a project adapting it to the local context. The municipality chose to build two-storey in-line residential cells completely above ground level with little gardens.

The first row of 10 cells was built in 1894 thanks to funding provided by Trento's Podestà Paolo Oss Mazzurana. After Podestà's death, the working-class district was sold in 1896 to the "Società di Mutuo Soccorso degli Artieri" which, in the following years, built several terraced houses, a multi-family building and a laundry.

In a building in Via Verruca 1, in the early 1900s, the "Central School for Embroidery" was founded in place of an artisan atelier, to teach and provide work for boys and girls aged 14 to 18. The embroidery school continued its work until the outbreak of the First World War and was then converted into a primary school in 1933 for children living in the Piedicastello area. It closed in 2000, due to low enrolment and the poor condition of the building. It was then readapted to new needs: it currently hosts medical clinics, the district meeting room and various associations [9].

In the second and third decade of the 1900s, companies specialised in metallurgical activities developed in the north-eastern area of Doss Trento.

In 1913, 'Trafilerie Punterie Trentine Hallier & Vavpetic', a company based along Via Doss Trento after the intersection with Via Caio Valerio Mariano, began its activity. It produced wire drawing machines, punteries, wire nets, locks, broaches, etc., employing an average of fifty workers. In 1932, the factory went into liquidation, presumably due to the financial crisis of 1929. Not far away and still along Via Doss Trento, the factory 'I.M.B.E.T. Industria Meccanica Broccami Elettrica Trentina' also opened, producing shoe broaches, iron, copper and brass rivets, precision tacks, special tacks for saddlers and upholsterers, drawing tacks, etc. It ceased operations in 1927 due to a lack of capital.

In 1928, the company 'Stabilimenti Metallurgici Trentini S.p.a.' was established, which took over the factory from 'Hallier & Vavpetic' until the end of the 1970s, and is remembered as 'The Jug Factory' [10].

In 1935, on the top of Doss Trento, the Mausoleum dedicated to Cesare Battisti was built, designed by architect Ettore Fagioli, in which the remains of this Italian irredentist hero (1875-1916) are preserved, and where an interior display tells of his tragic story in the context of the First World War (1914-1918). Other war memorials, created by a town committee and an association of Great War veterans, can be seen on the Doss.

The events of the Second World War (1939-1944) had a severe impact on the village of Piedicastello. Between 1940 and 1947, a unit of the Alpin troops built a new road to reach the summit of Doss Trento and started work on a museum inside the remains of the powder magazine of the Austrian imperial fortress. The museum, opened in 1958 and called the "Museo Storico delle Truppe Alpine", offers visitors an interesting exhibition that traces the tragic and heroic events of the Alpini.

In 1943, the iron bridge crossing the Adige was bombed. First replaced with a ferry, it was then rebuilt, a little further south, in reinforced concrete to reactivate communication with the Giudicarie Valleys. In the following years Piedicastello expanded with new buildings. Between the 1950s and 1970s, the district was subject to social housing interventions by the 'Istituto Autonomo per le Case Popolari' (I.A.C.P.), which worked to rebuild the houses destroyed during the second world war and to respond to the growing housing need generated by industrialisation. Many residential buildings were built on

the right bank of the river. In 1972, the institute was transformed into the 'Istituto Trentino per l'Edilizia Abitativa' (ITEA) and other low-income housing was built in Via Doss Trento (1980) and, later on, in the Vela area (2002). In the same years, private single-family or multi-family buildings were also built in some of the district's most outlying areas.

In the 1970s Piedicastello was strongly impacted by the construction of a bypass road and two tunnels crossing the Doss Trento. These works were severely disapproved by the locals from the beginning and throughout their whole existence, since they created a physical barrier dividing the district into two parts, also separating it from the area where the Church of Sant'Apollinare stands. Due to this, a group of residents spontaneously formed the Piedicastello Committee, whose goal is to protect the district against changes that may have a significant negative impact on the local community. In the 1990s, the committee fought for the relocation and redevelopment of the bypass and the district became traffic-free in 2007 when the tunnels were closed. The redevelopment of the urban area of the district started in April 2017 and was completed in November 2018 with the opening of the new district square. Recent landscape renovation projects have started to put this district's long-torn parts back together, but more interventions are needed to improve the quality of life of its inhabitants and to meet the goals of the ecological and circular transition.

Some historical images of the Destra Adige - Piedicastello district are reported in the SHEET - **HISTORY OF THE SITE** (A and B) in **Annex 9.3.1**.

#### **4.1.3 CURRENT STATUS OF THE SITE**

After the recent urban redevelopment works long awaited and strongly desired by the resident population, Destra Adige - Piedicastello is currently characterized by the following elements. Expanded and reconnected to the Sant'Apollinare Church and to the San Lorenzo bridge (over the Adige river), the district square occupies a total area of approximately 8,000 square meters. It consists of three macro-areas: the *historic square*, delimited by Via Brescia and by old buildings, together with the Piedicastello alley, has an area of approximately 2,200 square meters; the available commercial activities provide multiple functions along with the old fountain, a symbolic element not only for the square but for the entire neighbourhood; the *area around the monumental church-rectory* improved by the archaeological-architectural restoration works; the *green area* (approx. 2,800 square meters) including: a flat and equipped area for children (approx. 1,600 square meters) in the north part, a connecting area with shrubs and a pedestrian path (approx. 700 square meters) between the historical square and Via Brescia, and the flowerbed around the plane trees along Via Brescia (approx. 450 square meters). See SHEET - **DISTRICT SQUARE** in the **Annex 9.3.1**.

The current urban roundabout near the San Lorenzo Bridge was built to remove the physical barrier formed by the former ring road and its junction, which had extra-urban characteristics. The roundabout is smaller and crossable by pedestrians in four intersections. It has a central flowerbed planted with cypresses and shrubs. A tree-lined flowerbed, a bicycle path and pedestrian path run along the south side of Via Brescia.

The road system in the Via Papiria - Via Verrucca area is currently a one-way street; the footpaths have been widened, regularized and paved; the parking area has been reorganized and planted with trees both near the roundabout and next to the former Italcementi area to provide an adequate number of parking spaces for the neighbourhood, the nursery school and the church. The car parks are connected to the pedestrian path by stairs and ramps. In addition, a car park has been provisionally located on the site of the former Italcementi area, which seems to be causing dissatisfaction among local boards and the nearby Bruno Social Centre. See SHEET **ROUNDABOUT and ROAD SYSTEM** in the **Annex 9.3.1**.

North of Doss Trento and near the "Trento centro" motorway exit, there is the free 'ex Zuffo' parking lot with a shuttle bus service to the city center. The large area has parking spaces, a coach area (for loading and unloading travellers only), and camper van spaces for short stays equipped with an area for unloading and water supply. At the southern end of the area, there are parking spaces for private

bicycles as well as shared bicycles ones belonging to the 'e-motion' service. There is also a bike share in the neighbourhood square. See SHEET – **EX ZUFFO PARKING LOT** in the **Annex 9.3.1**.

The Doss Trento park includes an itinerary between nature and history. The two main access roads cross footpaths with terraces, steps and ramps recovered at the beginning of this century. On its summit, the park hosts the Alpine Troops Historical Museum, the remains of an early Christian Basilica and the Mausoleum of Cesare Battisti. The park is also a site of great environmental importance for its geomorphological, botanical, and faunal features [11]. Its naturalistic value is the subject of important protection. See SHEET – **DOSS TRENTO PARK** in the **Annex 9.3.1**.

The **Piedicastello tunnels** are two former road tunnels that cross the Doss Trento. They occupy a total area of over 6000 square meters for a length of about 300 meters. Converted into exhibition spaces, they are marked by two colours: black and white. The black gallery is located to the east, the white gallery to the west. They offer spaces for events, temporary exhibitions, and educational activities; they are not a traditional museum but a cultural space promoting history knowledge, a workshop and a participatory space. The tunnels are currently curated and managed by the “Fondazione Museo storico del Trentino” See SHEET – **PIEDICASTELLO TUNNELS** in the **Annex 9.3.1**.

The existing built heritage is both public and private. It mainly consists of residential buildings, multi-family blocks of flats or small single-family buildings located around Doss Trento (old village on the south side), to the north of the former Italcementi area (workers' houses from the early 20th century), and along the Adige river to the north of the bridge (council houses). The buildings require energy retrofitting as they have been mainly constructed before the entry into force of the energy efficiency regulations. Recently, national tax incentives aimed at improving energy, structural and architectural behaviour of the existing building stock (namely superbounus 110% and ecobonus 65%)<sup>2</sup> facilitated renovation works in the neighbourhood, such as interventions on the building envelopes, on architectural quality and on building facilities. However, such actions are punctual, and lack of a circular, innovative and systemic approach aimed at promoting and building a CCP Community. See SHEET - **BUILT HERITAGE** in the **Annex 9.3.1**.

The area is sufficiently equipped with services and collective spaces and hosts cultural and social events. Shops, bars, restaurants, and other commercial activities are mainly concentrated on the sides of via Brescia and to a small extent also along via Lungadige Apuleio. A building in Via Papiria hosts the Portland Theatre. This name clearly refers to the homonymous cement produced for many years in the Italcementi factory, one of the district's principal social landmarks. An old, abandoned building has been reused as a space for individual and collective creativity in the district. Portland Theatre collaborates with the local public authorities, the Piedicastello District and the Tunnels to carry out multiple cultural projects. Opportunities for aggregation, rehearsal studios and musical experiences are offered by Area Musica, an association based in Vicolo Piedicastello. Since 2007, the Centro Sociale Bruno has occupied an old building in Via Lungadige San Nicolò in the ex-Italcementi area, granted by the owner to 'Commons' on loan for use until the redevelopment of the area. See SHEET - **SERVICES AND COLLECTIVE SPACES** in the **Annex 9.3.1**.

Recent urban redevelopment works in the district have also renewed and adapted part of the public facilities. New materials and pipe diameters were adopted for the black- and white-water collection systems. The public lighting system serving the entire area has been almost completely replaced by lamps guaranteeing excellent illuminance/consumption efficiency, complying with the new regulations in the field of energy saving and light pollution.

---

<sup>2</sup> <https://www.agenziaentrate.gov.it/portale/web/guest/superbonus-110%25>

#### 4.1.4 EXPECTED FUNCTIONS BY THE MUNICIPAL PLAN

The Municipality and the Autonomous Province of Trento agree that the Destra Adige - Piedicastello district has the potential to become a hub for building redevelopment actions towards sustainable buildings and to contribute to the concept of Climate Positive Circular Communities (CPCCs).

Currently, the main urban planning tools defining the conditions for a social, cultural, environmental, and economic reconversion of the urban context of the Destra Adige – Piedicastello are: the General Regulatory Plan (PRG) in force with its variants, the “Destra Adige - Piedicastello” Master Plan definitively adopted by the Municipality of Trento in 2021, and the Urban Plan for Sustainable Mobility (PUMS) adopted in 2022.

With reference to the PRG in the pilot case, the following areas are identified:

- historical settlement (Ais) including the oldest core of the village consisting of the buildings located along Via Brescia and south-east of Doss Trento. The area is subject to conservation and redevelopment constraints. Article 32 of the Implementation Rules regulates the building interventions <sup>3</sup>.
- saturated built-up areas (B1) mainly located along the streets surrounding Doss Trento, especially along Via Brescia and Via Doss Trento. In these areas, all renovation works are allowed, but any increase in the existing above-ground volume is forbidden. Article 37 of the Implementation Rules regulates the building interventions<sup>4</sup>.
- integration and completion zones (B3 - B4) are partially built-up areas and located in the northernmost and southernmost part of Doss Trento. Article 38 of the Implementation Rules regulates them<sup>5</sup>.
- areas equipped for public green spaces (VP), located near the S. Apollinare Church, the roundabout and in the north side of Doss Trento. They are subject to Article 69 of the Technical Implementation Regulations<sup>6</sup>.
- zone subject to urban requalification (C5), located in the urban void of approximately 9,000 hectares left by the demolition of the Italcementi factory; it requires infrastructural and building retrofitting to improve the settlement quality through residential and tertiary uses. Article 42 of the Implementation Rules deals with this zone<sup>7</sup>.

---

<sup>3</sup> <http://webapps.comune.trento.it/gis/archivioweb/prg/norme/prgvigente/norme.pdf#nameddest=32>

<sup>4</sup> <http://webapps.comune.trento.it/gis/archivioweb/prg/norme/prgvigente/norme.pdf#nameddest=37>

<sup>5</sup> <http://webapps.comune.trento.it/gis/archivioweb/prg/norme/prgvigente/norme.pdf#nameddest=38>

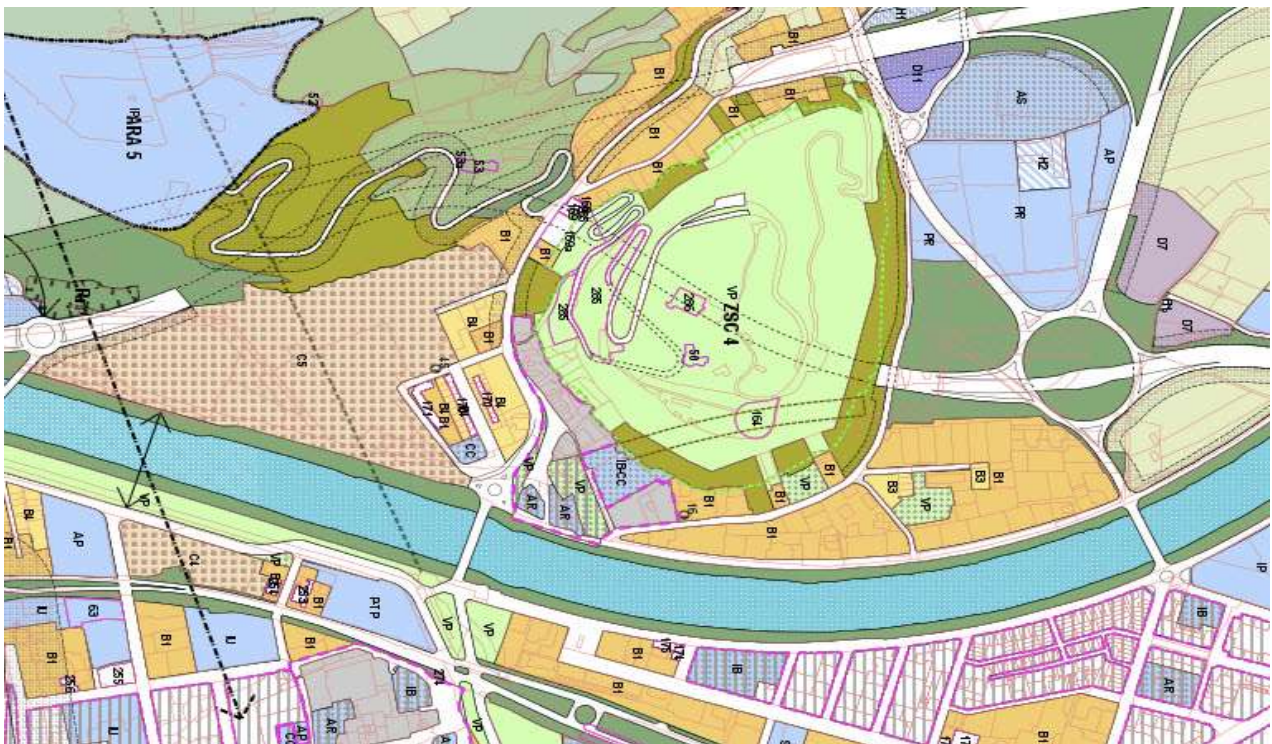
<sup>6</sup> <http://webapps.comune.trento.it/gis/archivioweb/prg/norme/prgvigente/norme.pdf#nameddest=69>

<sup>7</sup> <http://webapps.comune.trento.it/gis/archivioweb/prg/norme/prgvigente/norme.pdf#nameddest=42t>





*Figure 2. Aerial view of the Destra Adige - Piedicastello district (Source: Google Earth).*



*Figure 3. Zoning of the General Regulatory Plan (PRG) of Trento (Source: City of Trento).*

The “Destra Adige - Piedicastello” Master Plan was drawn up by Patrimonio del Trentino Spa, the company dealing with the real estate assets of Trentino’s public bodies [12]. The Master Plan aims to complete the redevelopment of the neighbourhood, to reduce traffic along Via Brescia and to accommodate a plurality of well-balanced functions in the former Italcementi area (almost entirely



publicly owned). The content of the Masterplan is the outcome of a long process of consultation involving Patrimonio del Trentino Spa, political decision-makers (at provincial, municipal and district level), technical services (at provincial and municipal level) and the Piedicastello community (district and committee).

The functions proposed by the Master Plan are aligned with those envisaged by the PRG, but have been dislocated by means of a hierarchy of relations and contiguity with existing buildings and functions. Specifically, the plan sets 20 facilities including residential buildings, public green spaces, cycle paths and commercial spaces, a research centre, a university student housing complex, a large car park with at least 2,000 spaces. Moreover, a cycle-pedestrian bridge south of the San Lorenzo bridge is planned to create a stronger connection with the part of the city across the river, while the former Italcementi chimneys are kept as a landmark of industrial archaeology (**Figure 4** and **Figure 5**).

In 2021 the Trento City Council approved the adoption of the Master Plan and the urban planning variant for the Destra Adige -Ex Italcementi area. This is an important moment for the city facilitating the beginning of the regeneration process of a widely discussed area. The objective is to strengthen the connection of the new neighbourhood with the Bondone Mountain and with the rest of the city, and to shift towards environmental sustainability and innovative mobility systems.

To shift territorial transformations towards low environmental impact building models, the Municipality of Trento approved the “Regulations to spread sustainable buildings” in 2006<sup>8</sup>. In addition to the regulations, building bonuses are provided to extend the diffusion of sustainable and quality timber constructions by art. 86 of the provincial town planning law of 2008 and by the tax breaks governed by the recent decree law no. 34/2020 in articles 119 and 121.

The former (PAT's Sustainable Building Bonus) are applicable to both renovation and new construction interventions, and can result in extensions of surface area or in the reduction of the construction tax<sup>9</sup>. The latter (Superbonus 110%) involve specific energy retrofitting, static consolidation or seismic risk reduction interventions. The installation of photovoltaic panels and infrastructures to charge electric vehicles are part of the subsidized works<sup>10</sup>.

The Sustainable Urban Mobility Plan (PUMS) addresses energy transition issues through actions and policies related to local mobility and its relationship with the territory, and is coordinated with the other planning tools. The PUMS envisages a substantial package of cycling interventions, reorganizes the existing interchange car parks such as the one in the former Zuffo area (Area 4), and implements smart mobility strategies by identifying places where to install electric recharging stations.

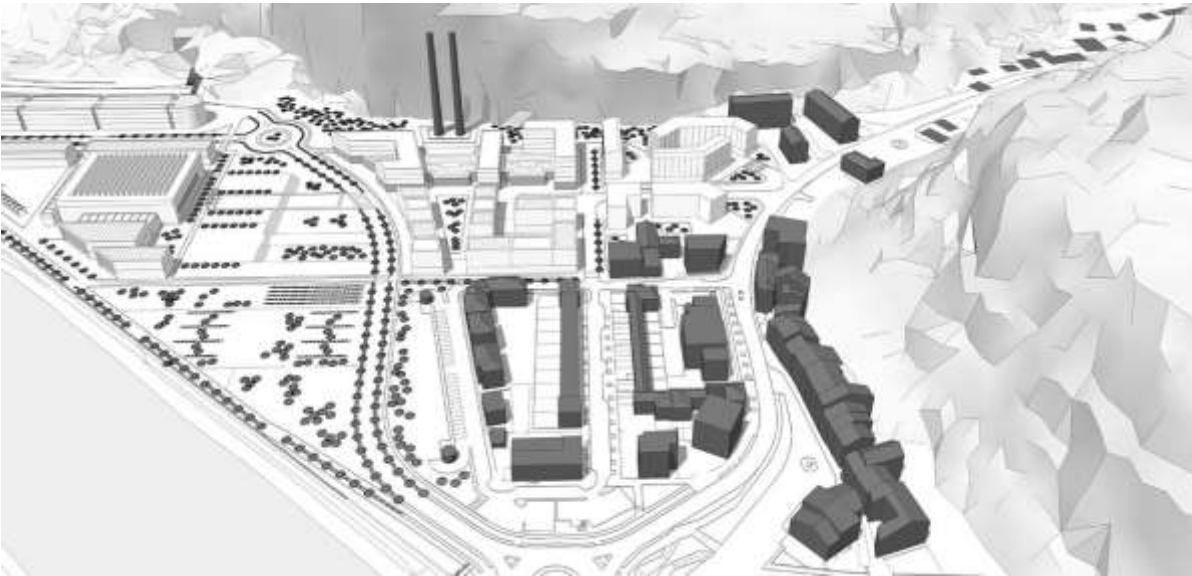
In the framework of funds allocated by the National Recovery and Resilience Plan (PNRR) and within the vision of a more sustainable local transport model in 2022, the Municipality of Trento approves the preliminary project to build the new section of the city cycle path from Piedicastello to the public park in the Le Albere district. In addition, the municipality intends to transform the parking areas into mobility hubs, i.e., “in strategic places in the urban area where the most important facilities are concentrated, such as: exchange car parks, public transport lines, sharing services, electric cars and micro-mobility, micro activities to increase commercial places” [13].

---

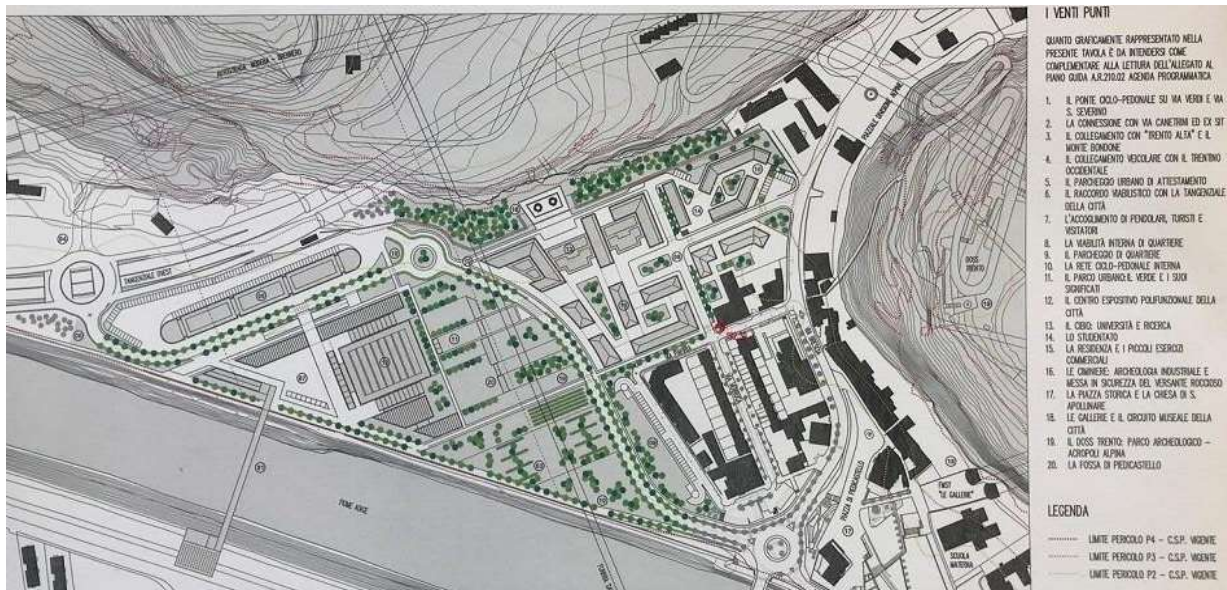
<sup>8</sup><https://www.comune.trento.it/Aree-tematiche/Ambiente-e-territorio/Urbanistica/Regolamenti-di-interesse-urbanistico/B24-Regolamento-per-la-diffusione-dell-edilizia-sostenibile>

<sup>9</sup> [http://www.urbanistica-dati.provincia.tn.it/cms\\_storage/urbanistica/gp2091\\_2021\\_allegato\\_edilizia\\_sostenibile.pdf](http://www.urbanistica-dati.provincia.tn.it/cms_storage/urbanistica/gp2091_2021_allegato_edilizia_sostenibile.pdf)

<sup>10</sup> [https://www.energiaenergetica.enea.it/images/detrazioni/Normativa/ART.119\\_E.121.pdf](https://www.energiaenergetica.enea.it/images/detrazioni/Normativa/ART.119_E.121.pdf)



**Figure 4.** Visions for the Destra Adige area according to the “Destra Adige – Piedicastello” Master Plan by Patrimonio del Trentino Spa (Source: <https://www.patrimoniotn.it/property/riqualificazione-urbanistica-destra-adige-piedicastello>).



**Figure 5.** Twenty points of “Destra Adige – Piedicastello” Master Plan by Patrimonio del Trentino Spa  
 (Source: <https://www.patrimoniotn.it/property/riqualificazione-urbanistica-destra-adige-piedicastello>).

## 4.2 DESIGN PLAN

In Europe, the building sector is responsible for 36% of annual CO2 emissions, 40% of energy consumption, 50% of raw material extraction, 21% of drinking water consumption [14]. At the same time, this sector is also responsible for one third of the total waste produced; in Italy 41.3% of all special waste comes from the construction sector [15]. The situation is expected to worsen without swift and decisive actions. The real estate sector is a powerful driver of the global economy and also a crucial sector for the achievement of many of the UN SDGs. In this scenario, cities will play a crucial role if they transform themselves into CPCCs.

**Could the city of TRENTO become a CPCC?** Trentino, a region that is technologically advanced and accustomed to competing on the basis of innovation and sustainability, must necessarily move within a European vision of transition towards a circular economy, exploiting opportunities and promoting concrete initiatives.

The TRENTO demonstration project in the Piedicastello district represents an innovative test in order to:

- develop and test a new paradigm of “integrated circular CPCC design” adopting a multidisciplinary approach to (RE)DESIGN buildings using digital tools (BIM, Digital Twins) in a multi-stakeholder cooperation;
- apply integrated strategies, solutions and technologies that maximise energy efficiency, minimise greenhouse gas emissions and life cycle costs, optimise occupant well-being and ensure high architectural quality.

TRENTO demo case consists of two building interventions. The first one is the *Design of a New Construction* in Area 4. The second one is the *Design of an Existing Building Refurbishment* in Area 4.

**SUSTAINABLE BUILDING (RE)DESIGN** planning is a process that analyses *requirements* as well as *potentials and opportunities*, defines *architectural, environmental, social and economic objectives*, and identifies related *strategies and solutions* to achieve them.

### 4.2.1 ANALYSIS REQUIREMENTS AND POTENTIALITIES/OPPORTUNITIES

The start of an ecological and circular transition represents a highly relevant strategic input with the shift from the “need” for energy efficiency to the “opportunity” to (re)design building products at



different scales using sustainable and/or circular economy materials, and Integrated Circular Design Solutions (ICDSs). The ICDSs that can be applied in the building sector today are collected in **Annex 9.1** “Catalogue of integrated circular design solutions” of this document.

All phases of a building's life cycle contribute significantly to current greenhouse gas emissions. For this reason, reducing the use of concrete and steel in the building sector contributes to lower material-related greenhouse gas emissions. Wood is an important renewable natural resource obtained from Italy's extensive forests and used for a wide variety of purposes, not only for the construction of buildings but also for panels, semi-finished products, and insulation. Wood is a local and circular raw material that has excellent mechanical properties and thermal insulation.

The massive forest cover testifies to the strong link between Trentino and its forests. In Trentino, forests currently cover an area of 392.000 hectares; this is this is 63% of the provincial territory. In terms of ownership, 76% of the forests are public. Due to the reduction of traditional activities related to mountain rural and pastoral practices and the sustainable management of the resources, the forest is constantly evolving. The use of the forest heritage is based on Forest Management Plans (FMPs), which are the tool for monitoring and managing forests and the mountain territory [16]. Spruce (*Picea abies*), (*Abies alba*), larch (*Larix Decidua*) and beech (*Fagus sylvatica*) are among the most widespread forest species. In Trentino, there are already various technologies and production chains linked to the use of these wooden species in the construction sector.

The Autonomous Province of Trento has launched a policy focused on sustainable forest management, paying attention to environmental protection, strengthening competitiveness and improving socio-economic conditions in the sector for some time.

With Provincial Law No. 16 of 27 August 1992, the PAT mandates the Trento Chamber of Commerce of developing timber markets and the valorisation of forest resources in the provincial district. In 1993 the Chamber of Commerce launches the 'Wood Project' aimed at the organisation of common local markets. The recent programme agreement between PAT and Chamber of Commerce, which took place in June 2020 for the period 2020-2023, identifies the Trentino wood sector as a sector to be valorised, in particular through specific actions aimed at "developing the Trentino wood market and promoting innovative forms of use and product qualification, also in relation to the adoption of certification systems" [17].

Today, Trentino is an important cluster in the wood industry. But, in Trentino there is also an extensive network for research into timber constructions and the energy requalification of buildings. A new solution called “Renew-Wall“ was recently developed for insulating buildings with Trentino wood. “Renew-Wall” is a newly developed and non-intrusive modular system for the retrofit of existing buildings, consisting mainly of an insulated wood-based panel already integrated with windows, shutters and CMV with heat recovery [18]. In addition, the city of Trento is one of the seven European cities involved in the “Build-in-Wood” project [19]<https://www.build-in-wood.eu/trento>.

Furthermore, the ARCA system should not be forgotten in this context. ARCA is a rating system focused on timber construction, funded by the Autonomous Province of Trento in 2011. It has requirements to ensure the quality, durability, and sustainability of the constructions. The certification aims to guarantee to owners and developers the performances of the building and the quality of their investment, and to promote a sustainable construction way-of-think approach to all the stakeholders (designers, builders, suppliers) through measurable and comparable criteria.





The general REQUIREMENTS to be met and the POTENTIALITIES/OPPORTUNITIES are related mainly, but not exclusively, to the issues of sustainability and the culture of circularity. REQUIREMENTS are listed in **Table 1** and POTENTIALITIES/OPPORTUNITIES of both projects are listed in **Table 2**.

**Table 1.** List of general requirements for the Design of the New Building and Renovation.

NEW BUILDING	EXISTING BUILDING REFURBISHMENT
Be <b>innovative</b>	
Have a <b>timber frame</b>	Use mainly <b>wood-based solutions</b>
Be <b>energy positive</b>	Achieve <b>high energy performance</b>
Assure <b>high environmental comfort</b>	Assure <b>high environmental comfort</b>
Integrate <b>Nature-Based Solutions</b>	Be a <b>multifunctional</b> building intervention
Use <b>sustainable materials</b>	Be a <b>replicable</b> and <b>scalable</b> building intervention
Be a <b>smart building</b>	Be characterised by <b>speed of construction</b> and <b>possible disassembly</b>
Be a <b>climate responsive</b> building	Be <b>compatible with Superbonus</b> or its evolutions
Be <b>flexible</b> in adapting to future needs	
Be <b>reusable</b> or <b>recyclable</b>	
Be of <b>innovative architecture &amp; BIPV</b>	
Be <b>inclusive</b>	
Have a <b>high architectural quality</b>	
Ensure <b>safety</b>	
Be <b>cheap</b>	

**Table 2.** List of potentialities and opportunities.

POTENTIALITY OF	OPPORTUNITY OF
Increasing the competitiveness of timber compared to “traditional” materials through the development of innovative solutions	Testing the creation of new sustainable supply chains that mainly use timber for both new construction and renovation
Connecting with the nearby energy geostructure	Providing seasonal thermal storage to the CPCC using disused road tunnels; reducing power needs, costs and emissions
Stimulating private property to join neighbourhood redevelopment with the creation of One Stop Shops	Becoming a neighbourhood model for innovation and sustainability
Reducing construction time and jobsite impacts (reducing dust and noise) for both new construction and refurbishment	Verifying the replicability potential of the building interventions
Contributing to the improvement of the quality of the indoor environment of buildings and the quality of the life of the citizens	Promoting the culture of circularity and CPCCs and creating awareness raising in the neighbourhood and community

#### 4.2.2 PROCEDURE AND STAKEHOLDER INVOLVED

In order to face the great current and future challenges a mutual involvement of multiple actors is required (Figure 6). The creation of value for all those directly and indirectly involved in a project is essential for building a common purpose and approaching the complex issues affecting our planet. The importance of stakeholder engagement is recognized in promoting environmentally and socially responsible behaviours of companies from all sectors and of the community.



*Figure 6. Variety of actors involved in the sustainable building re/design).  
Source: ARV/NTNU/HABITECH.*

**SUSTAINABLE BUILDING (RE) DESIGN** for CPCCs brings along the need to involve local stakeholders in order to collect needs and requirements, identify potential sources of conflict, strengthen the variety of design options, and improve decision-making and implementation processes.

Participatory design and stakeholder engagement practices are fundamental in situations involving the regeneration and redevelopment of buildings and urban spaces with criteria of environmental, social and economic sustainability in a circular economy perspective. The implementation of community activities and Living Labs focusing on "Social renovation" and "Energy transition" should not be missing in this context. They are being developed within the framework of WP3 - task 3.3.

The **GOALS of stakeholder engagement** are:

- TO COLLECT INFORMATION AND FEEDBACK to support strategic choices and decisions in the design process stages: Early Concept Design (ECD), Design Development (DD), Detailed Design (DeD);
- TO PROMOTE A CULTURE built on the importance of Stakeholders engagement in an integrated design process for CPCCs;
- TO DIRECTLY INVOLVE STAKEHOLDERS, COMMUNITY AND CITIZENS LIVING IN THE NEIGHBOURHOOD affected by the ARV project activities, in order to develop an integrated and neighbourhood-scale approach to building renovation, and in order to train them on the topics of energy transition, geothermal energy and energy communities.

The **STEPS of stakeholder engagement** are:

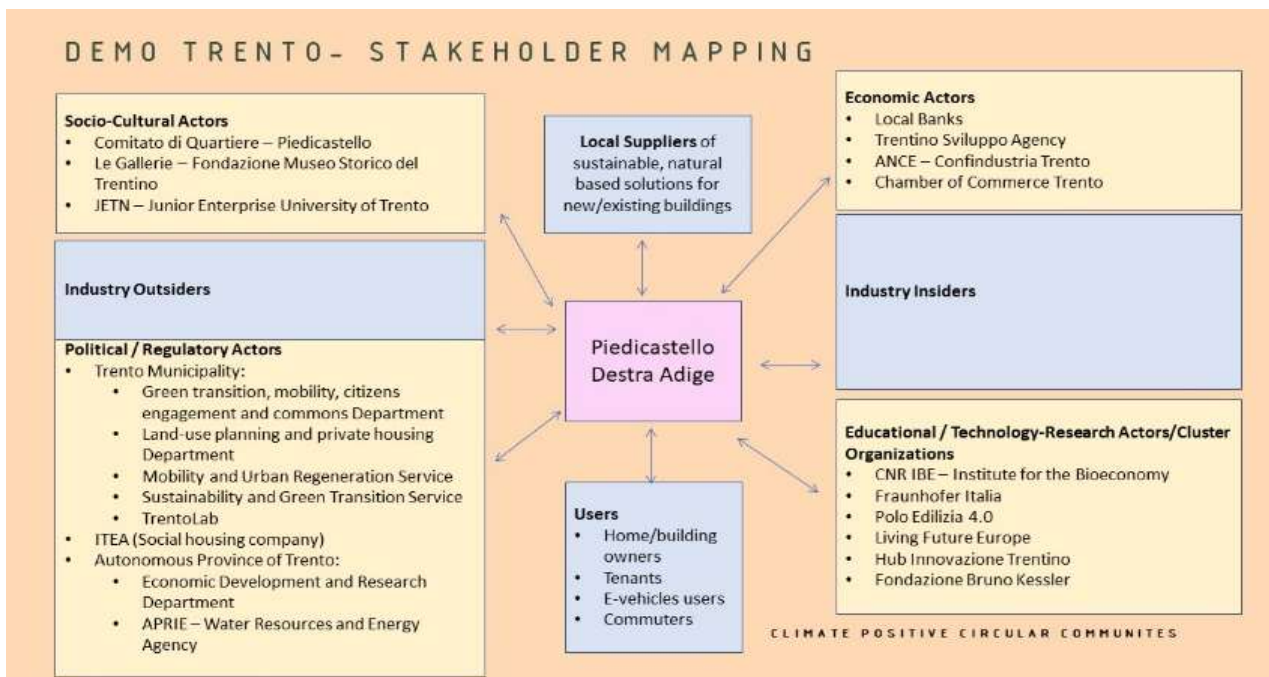
- IDENTIFYING and MAPPING of collaborative stakeholders to be involved in the activities of the design process;

- **DEFINING and LISTING** of the relevant issues to be addressed during the consultations (e.g. vision of the area project toward a CPCC in terms of strengths, weaknesses, opportunities, and threats; location of the building interventions and its relationship with the neighbourhood and the city; functions and end users; needs – requirements – performances, sizing, etc.);
- **DEVELOPMENT OF THE ACTION PLAN** in term of resources, initiatives of involvement (e.g. meetings, interviews, online questionnaire, forum, workshop, focus group, etc.), analysis and implementation of the results.

Stakeholder identification is the first step of stakeholder engagement. It identifies all those who can affect or are affected by the project, each with their own role and weight. In this context, the "internal" stakeholders are the organisations belonging to the ARV partnership involved in the Trento demo case (researchers and design team of the university and research unit, manufacturers, suppliers, etc.), while the "external" stakeholders are the owners, policy makers, end users, community, etc.). The identification of key collaborative persons is fundamental for working together, collaborating and maintaining productive relationships.

Stakeholder mapping (**Figure 7**) explores the relationships between actors as well as their links with the project. Its result is the actor-oriented map, a visual depiction of the key organizations and their relationships.

Stakeholders for the *Design of New Construction* and the *Design of Existing Building Refurbishment* of Trento demo case are listed and classified respectively in Tables which are reported in paragraphs 5.1.1, 5.2.1, 5.3.1 and 6.1.1, 6.2.1, 6.3.1 of this document. Please note that these tables and maps, (final product of a joint work with the partners HABITECH and EURAC working also in WP3) refer to the activities of the first and second year (2022-2023) of the ARV project, and can be modified and integrated.



*Figure 7. Stakeholder mapping of the Trento demonstration project. Source: HABITECH.*

The **ACTION PLAN of stakeholder engagement** includes:

- **LEVELS OF ENGAGEMENT** that move from a more passive mode (1 and 2) to a more active mode (3), in particular:
  - 1) informing: bringing about knowledge and awareness raising
  - 2) consulting: asking and/or acquiring information

### 3) collaborating: cooperating and working together

- ENGAGEMENT TOOLS including direct on-site or remote interaction, internet, press, TV, etc.
- ENGAGEMENT METHODOLOGIES including meetings, public lectures, research, one-to-one interviews, online survey or forum, shared projects, joint initiatives or activities with other WPs, company visits, demo case visits, etc.
- PREPARATION OF INFORMATION MATERIAL regarding the ARV project and the demo case (e.g. presentations, summary of the project progress, etc.).

#### 4.2.3 ARCHITECTURAL, ENVIRONMENTAL, SOCIAL AND ECONOMIC GOALS

The built environment contributes to the establishment of communities, which must be SUSTAINABLE from architectural, environmental, social, and economic point of view to ensure a high quality of life for all. The Trento demonstration project intends to launch and test a collaborative design and creative space where researchers, architects, engineers, students, policy makers and manufactures work together to make ARV project vision a reality. In particular, the Trento demo case works towards implementation of a CPCC in the Trento city, focusing on new positive energy buildings and high energy efficiency refurbishment applying the EU Circular Economy Principles for Buildings Design.

The built environment is a major source of energy consumption throughout the life cycle of buildings. Buildings must be (re)designed to limit energy consumption in use, for example by using appropriate materials, and to produce and recycle energy. This means designing and constructing buildings optimising the 'anatomy' of the building not only to improve its performance, reduce energy consumption and employ innovative sources of renewable energy but also to achieve building envelopes that are architecturally pleasing (new Bauhaus) and easy to implement.

The building sector is a major consumer of natural resources and contributor to waste. The process of constructing new buildings and the process of building renovations is producing waste. When buildings are demolished, most of the existing materials and components are lost. The same applies to renovations, which transform vast amounts of already extracted and treated materials into waste. Important environmental goals are: reduce the use of resources overall, significantly limit the use of non-renewable natural resources, emphasise the use and reuse of local materials, reduce the waste production during construction activities.

Positive energy buildings and NZEBs are an opportunity not only to save energy and reduce CO<sub>2</sub> emissions, but also to improve the health and well-being of people who normally spend 90 per cent of their time inside buildings. Reducing emissions from buildings, particularly in the cities, can reduce pollution and improve air quality, benefiting the health of everyone living in cities.

The building sector is central to economic development. It is strategic that this sector increasingly takes on sustainable development as the key to change for the quality growth of our country's local communities. CPCCs can contribute significantly to increase of jobs to realise them as the demand for sustainable new construction and renovation grows. The life cycle of a building (from conception to construction, management and even renovation) impacts a wide range of people, and provides many opportunities for work.

Last but not least, goal of the Trento demonstration project is to educate and create awareness in all stakeholders involved. In order to bring the European Green Deal closer to people and to accelerate and achieve the transition towards CPCCs, it is important to have the community, and in particular the citizens, on board to make sure this transition is accepted and feasible for all.

#### 4.2.4 STRATEGIES AND SOLUTIONS

The basic idea introduced by the ARV project is to address integration, circularity, and simplicity in the processes of planning, design, construction, and use of CPCCs. The overall aim of the Trento

demonstration project, for what concerns the WP4, is to demonstrate and validate attractive, resilient, and affordable strategies and solutions that will significantly speed up deep energy renovations and deployment of energy and climate measures in the construction and energy industries. The Trento demo case focuses on the strategies and solutions shown in **Table 3** and **Table 4**.

**Table 3.** List of strategies and solutions for the New Building.

STRATEGIES AND SOLUTIONS FOR THE NEW BUILDING
Use a local and circular raw material for the structure (structural timber) and consider one or a combination of the following systems: post and beam construction, Cross Laminated Timber Panels (X-Lam), or framed wall
Produce more energy than the building consumes from renewable sources
Design building components to be long-lasting, easy to repair, reused, remanufactured, refurbished, and recycled
Integrate passive systems (ventilated facades, active thermal mass, natural ventilation) and active systems (photovoltaics, combination of mechanical ventilation and geothermal heat pumps also with connection to the energy geostructure) for energy saving and indoor living comfort
Include NBSs introducing green roof or green facades
Involve the installation of technology systems for monitoring the building performances
Design the optimized building according to specific characteristics of that particular site, to minimize extreme energy use and have a reduced impact on the natural environment (with particular attention to natural and mechanical ventilation concepts)
Design on the basis of a standard module to ensure adaptation to future needs (extensions or additions) and to facilitate construction features (transportability, etc.)
Possibility for the building to be reusable by changing its use, or to be relocated to another site, or be disassembled but with construction materials recyclable; have potential for future adaptation, re-use or deconstruction
Design with spatial quality and accessibility for persons with disabilities and senior citizens
Employ strategies and design measures for fire and seismic safety of the building
Minimize the disruption for citizens during the construction process, i.e., construction time, noise, dust, etc.
Provide comfortable indoor and outdoor conditions with spatial quality and accessibility for persons with disabilities and senior citizens
Convert the building envelope into electricity-producing surfaces with architectural and aesthetic considerations of the integration of BIPV/BAPV

**Table 4.** List of strategies and solutions for the Renovation.

STRATEGIES AND SOLUTIONS FOR THE EXISTING BUILDING REFURBISHMENT
Use a local and circular raw material for the structural framework and insulation
Zero disruption of building occupants (renovate while in use)
Use panels that provide architectural and energy (summer and winter) requalification, and environmental comfort; use panels that integrate high-efficiency windows, shutters and VMC with heat recovery
Use solutions with economies of scale capability
Not adversely affect the fire and seismic safety of buildings



## 5. DESIGN OF THE NEW CONSTRUCTION

---

### 5.1 EARLY CONCEPT DESIGN

---

The New Construction for the Trento demonstration project is an experimental service building (hereinafter referred to as the New Building) to be located in the parking lot called “ex-Zuffo” which is in Area 4 of the Piedicastello district.

Early Concept Design (ECD) refers to the first ideal representation of the New Building. Its objective is to define and present the main qualitative and functional characteristics of the building, highlighting its most significant aspects.

The final product of the ECD of the New Building is the result of a participatory design process. This chapter briefly describes the *procedures and stakeholders involved, the architectural, environmental, social, economic goals* and the *strategies and solutions* pursued.

#### 5.1.1 PROCEDURE AND STAKEHOLDERS INVOLVED

EURAC and UNITN started the participatory design process for the New Building. Subsequently, the design process was developed with the collaboration of the other ARV partners which are POLITO, HABITECH and DOLOMITI Energia. Other stakeholders involved in the ECD phase were the Trento Municipality, the Users, and the Community of Piedicastello district (see **Table 5**).

Community of Piedicastello district and its neighbourhood committee were invited to the first public meeting with round table and discussion. In the first part of the meeting, the citizens listened to policy makers, experts and technicians who introduced the ARV project and the aims of the Trento demonstration project; in the second part, the participants were able to express their views and opinions (**Figure 8**).



*Figure 8. Public meeting, 24.06.2022. Photo: UNITN.*

Information, consultation, and collaboration among stakeholders took place through meetings (**Figure 9**). Participants, dates, locations, and topics discussed are listed in the "Table of Meetings with Stakeholders" (see **Annex 9.3.2**). The sharing of material concerning the concept design development took place through the transmission of attachments via email (i.e. working papers, flyers, etc.) and power point presentations. The outcomes of these meetings were reported in the local WP4 meetings. In addition, the use of an online survey for the involvement of End Users was important.



*Figure 9. Stakeholder meeting at the Trento Municipality, 20.09.2022. Photo: UNITN.*

All stakeholders contributed directly or indirectly to the development of the ECD of the New Building. The design activities dealt with the analysis of the context, the definition of function, form and construction system of the New Building.

EURAC mainly took care of the general coordination of the activities by assuming the role of facilitator. UNITN and POLITO took care of the technical-scientific part by involving the stakeholder key persons from the beginning. EURAC and HABITECH played an important role in the stakeholder engagement process by organising the public meeting, promoting and participating in other activities (i.e. survey online dissemination).

From the beginning, the political and regulatory role of the Trento Municipality was relevant. Council members and engineers of the “Land-use planning and private housing Department” and the “Mobility and Ecological Transition Department” collaborated on the location of the New Building in Area 4 and its introduction as a pilot project in the PUMS. After reiterating the interest in the New Building and recognising its importance in terms of scalability and implementation in other contexts, the Trento Municipality started the authorization process.

For the definition of the construction system, the role of HABITECH was very important, in particular the contribution of the local companies involved later in the DD and DeD phases. DOLOMITI Energia contributed to the preliminary verification of specific aspects related to the function of the New Building.

Considering the importance of collecting the opinions of potential End Users, UNITN developed an online survey in order to verify the functional programme of the New Building (**Figure 10**). The questionnaire serves a dual purpose of:

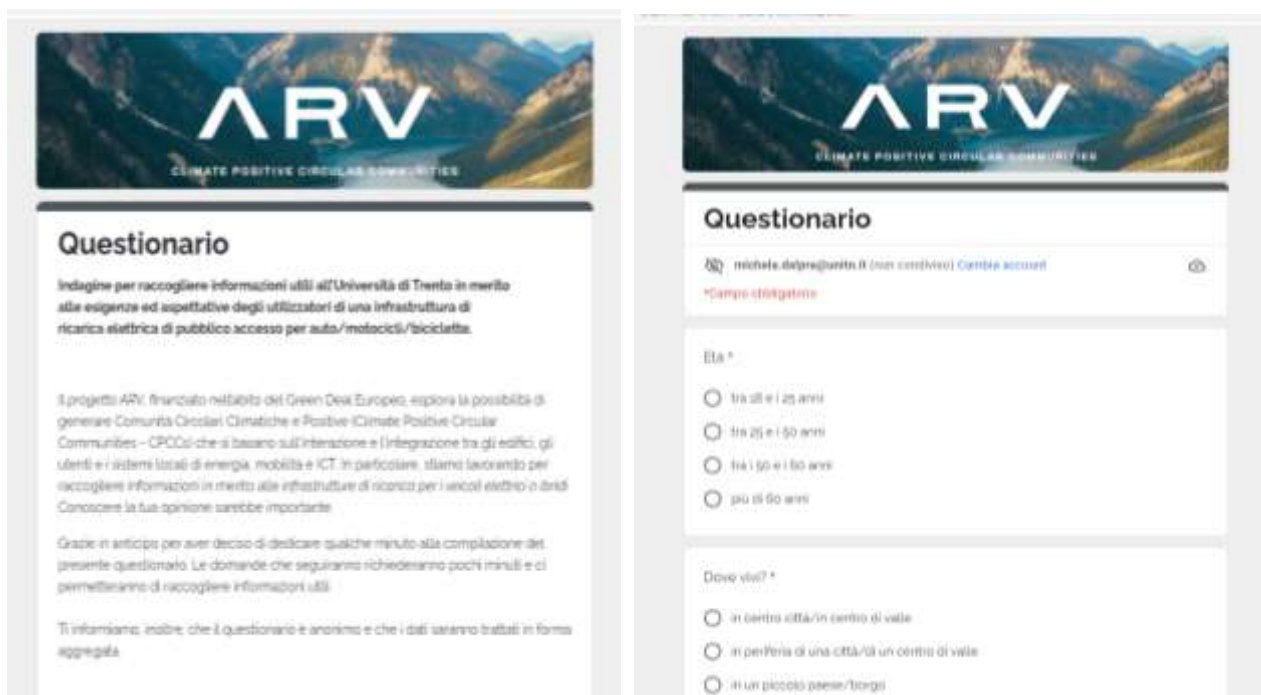
- investigating the need/expectations of citizens who are owners or users of electric or hybrid vehicles on possible services that could improve the recharging and waiting times at dedicated stations;
- communicating and promoting the ARV project and the importance of citizens’ engagement in the same.

The short questionnaire was structured with “structure” questions to define the basic characteristics of the respondents (such as age group and where they live), “context” questions to introduce the reference scenario for the intent of the study, and “purpose” questions to answer the objectives of the survey. The

questions are closed or semi-open, in some cases with the possibility of giving one or more answers, in other cases with the possibility of specifying the answer using one's own words (see **Annex 9.3.3**).

In order to contextualize the survey and also promote the ARV project, a short introduction was included in the questionnaire itself and in the text of the email with which the survey was disseminated. The questionnaire is anonymous and does not include questions which can potentially identify the respondent (e.g. name, gender, etc.). All responses to this survey were kept strictly confidential and the survey data were reported only in aggregate form or in a manner that does not allow individual responses to be identified. No individual response was disseminated or published.

The results of the online survey were presented and discussed during the stakeholder and local WP4 meetings. They essentially confirmed the initial hypotheses and provided some input for the further development of the early concept design. For further details, please refer to the “Summary Report of the online survey” (see **Annex 9.3.4**).



**Figure 10.** Online survey for collecting information from End Users about the purpose of the new building. Source: UNITN.

Another initiative organised by UNITN was to involve students of the course entitled “Sustainable building and architecture” of the Department of Civil, Environmental and Mechanical Engineering. The idea was to broaden the Community involvement by organizing a design workshop with a focus group of future design professionals in order to promote the ARV project and to collect ideas, visions and design proposals for the New Building.

This initiative, that is still ongoing at present, offers an opportunity for information/education, awareness-raising and participatory understanding of the new paradigm of ‘integrated circular design of CPCCs’, bringing the focus group of the student community closer to the concept of positive building (learning by doing). A total of 15 students are involved (**Figure 11**), that are working in small groups during the first semester of the academic year 2022/23 (from September 2022 to February 2022). The expected results are a cultural reflection, a concrete application to a case study and the collection of proposals from young people who in the immediate future will be able to design by applying the new design paradigms promoted by the ARV project. The results will be presented and discussed during the stakeholder and local WP4 meetings of the DD of the New Building.



**Figure 11.** Design workshop with the students of the course entitled "Sustainable building and architecture" of the University of Trento. Photo: UNITN.

**Table 5.** List of stakeholders of the Design of the New Building.

	CATEGORIES	GROUPS	KEY PERSONS	LIFE CYCLE PHASES
INTERNAL ACTORS belonging to the ARV partnership	UNIVERSITY	UNITN (DICAM)	proff. R. Albatici, A. Frattari, M. Dalprà proff. M. Piazza, I. Giongo, proff. P.Baggio, A. Prada prof .G. Massari	Design (ECD, DD, DeD)
	UNIVERSITY	POLITO (DAD)  POLITO (DISEG)	proff.G. Callegari, D. Bosia, phd student G. Ricciardi ing. G. Roccasalva arch. PhD L. Savio arch. P.Simeone prof. M. Barla, eng. A. Insana	Design (ECD, DD, DeD)
	RESEARCH UNIT	EURAC	dott. D. Vettorato	Design (ECD, DD, DeD)
	ENERGY AND ENVIRONMENT DISTRICT	HABITECH	dott. M. Curci	Design (ECD, DD, DeD) Production Construction
	MANUFACTURING COMPANY	HABITECH (ARMALAM)	eng. F. Ferrario arch. D. Casagranda eng. M. Tommasini	Design (ECD, DD, DeD) Production and Construction
	MANUFACTURING COMPANY	HABITECH (XLAM Dolomiti)	eng. D. Fanti	
	ENERGY PROVIDER	DOLOMITI ENERGIA Spa	eng. N. Fruet , eng. F. Righi	Design (ECD, DD, DeD) Use
EXTERNAL ACTORS not belonging to the ARV partnership	OWNER/LOCAL AUTHORITY	Municipality of Trento	Policy makers council member M. Baggia council member E. Facchin eng. S. Fedrizzi eng. G. Franzoi	Design (ECD, DD, DeD) Construction Use
	COMMUNITY	Residents in Piedadcastello district  Citizen of Trento city	Representatives and/or small focus group - eng. C. Geat	Design (ECD, CD, DD) Use

		Students of University of Trento	Representatives and/or small focus group CliSustainable building and architecture course aa 22/23	
	USERS	E-vehicle users Commuters	Focus group	Design (ECD, CD, DD) Use
	MANUFACTURING COMPANY	SOVECAR Group	dott. M. Giglioli D. Zucal	Design (DD, DeD) Production and Construction

### 5.1.2 ARCHITECTURAL, ENVIRONMENTAL, SOCIAL, ECONOMIC GOALS (WHAT, WHY, WHO, HOW)

After a number of unfortunate town-planning choices that have caused great damages that are still visible today, the intent of the ARV project in the city of Trento is to start a participatory process that will transform the Destra Adige - Piedicastello district into an incubator and demonstrator of a new way of thinking about local communities, oriented towards climate respect with a view to a circular economy and energy self-sufficiency, and through the development of simple and inexpensive solutions that can be rapidly replicated and exported to other districts and cities. To this end, it was decided to design an experimental wooden demonstration building that systematizes innovative design, construction, and plant engineering methods. The issue of positive energy building is studied to define design requirements that convey not only more efficient energy performance, but also a new culture for positive energy building design.

The basic idea behind this design process is to create a new **EV CHARGING HUB with INTEGRATED SERVICES** in an area that will take on a dual function in the near future, linked to commuting and tourist movements to and from the Trentino valleys, and that will become a "mobility hinge", also in expectation of increasing attention to the themes of railways, soft mobility and smart mobility according to the general objectives of the PUMS. Therefore, the functions of the area are:

- WAITING area for people stopping for medium to long periods for different reasons (e.g. electric vehicle recharging, commuting, car-pooling, work appointments or other) and for those who need space for short to medium term where they can carry out some activities, both recreational and work-related.
- TRANSIT area zone for people commuting or moving quickly for other reasons (work and tourism primarily), access to vehicle parking, access to sharing services (i.e. car-sharing), access to the city (i.e. tourists), access to logistics services (i.e. receiving shipments at hub lockers), etc.

### 5.1.3 STRATEGIES AND SOLUTIONS (2023)

The integrated design process with stakeholders defined the location of the New Building in Area 4, the definition of the functional programme, the preliminary sizing, the definition of the construction grid, the elaboration of schematic floor plans, sections and 3D views.

The location of the New Building is in ex Zuffo parking lot (**Figure 12**) owned by the Municipality of Trento. It will be located in the northern part (**Figures 13 and 14**), considered to be the most suitable and strategic in relation to the PUMS objectives. Contextually to the development of the building design of the New Building, the Municipality of Trento has undertaken to redefine the main axes of access and modal interchange of this parking area.

The activities proposed for the functional programme of the New Building and its surrounding outdoor space are divided into three macro-areas.

The first related to the VEHICLE includes the activities of *Recharge, Wash and Repair shop*.

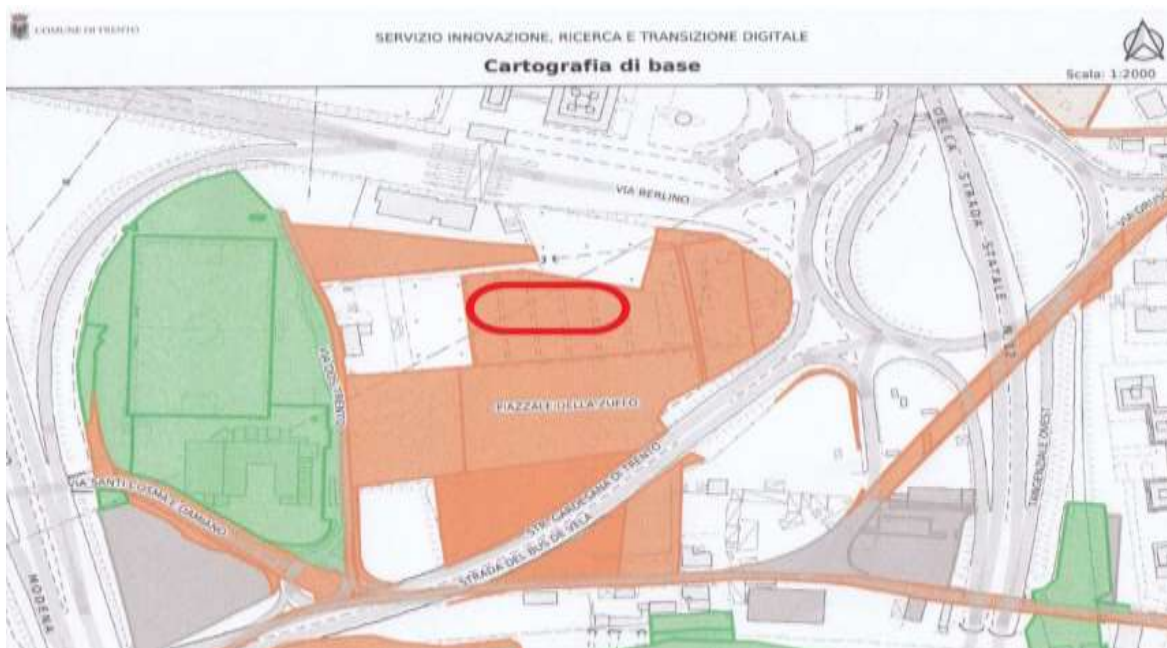


The second area refers to the PERSON and consists of activities that are grouped in the categories called *Services*, *Trade* and *Other*. The *Services* category includes: info point, offices and meeting room (Management); relax, work and play (Relax); Bus, bike, scooter, Pedestrian and Taxi (Intermodal). The *Trade* category includes: bar, shelves, typical products, (Food) and basic products (Wear). The *Other* category concerns storage and systems.

The third area concerns COMPLEMENTARY FUNCTIONS such as green spaces and mobility.



*Figure 12.* View of the ex Zuffo parking lot. Source: Google Earth.



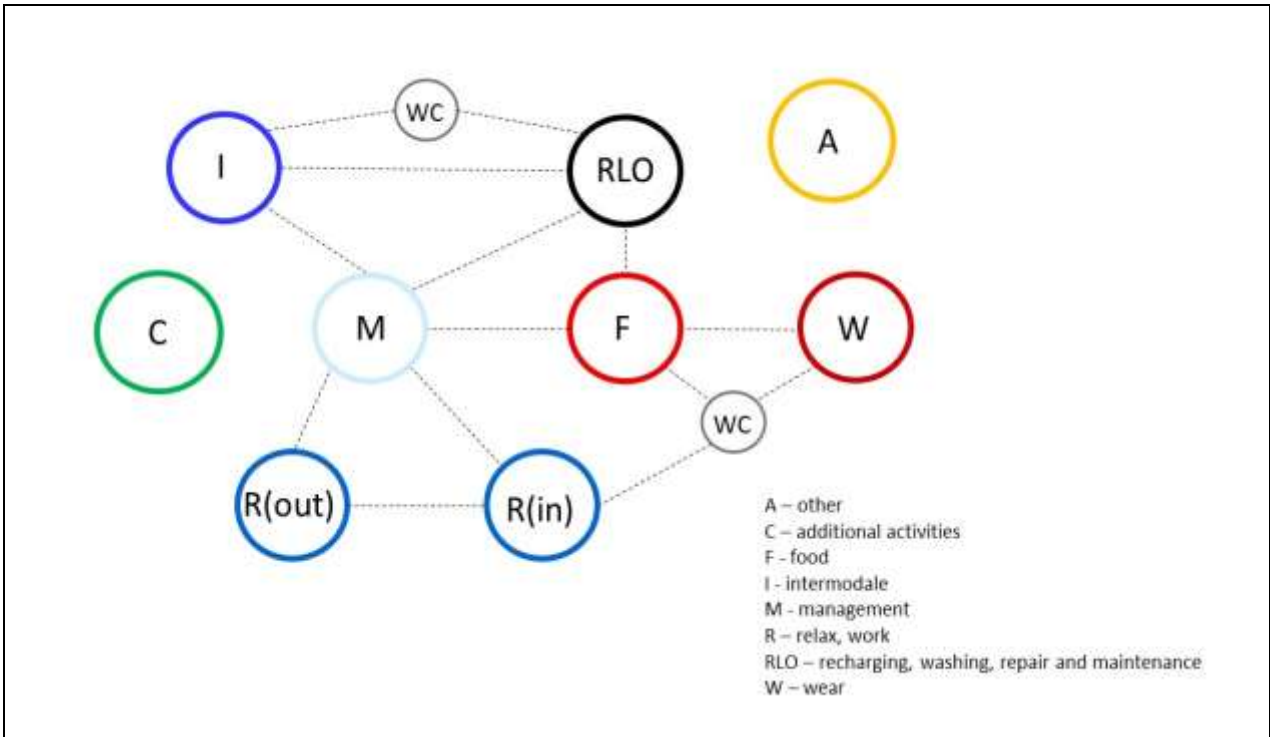
*Figure 13.* Area designated for the location of the New Building (in red). Source: UNITN.



**Figure 14.** Current state of the intervention area (in red. Source: Google Earth.

**Figure 15** depicts the interaction among the specific activities grouped into categories as follows:

1. Intermodal (I): bus, bicycle, scooter, taxi, pedestrian, sharing/rental, pooling, shuttle service, hub lockers;
2. Relax and work (R): rest, work, play, reading room, phone charging, smoking area, smart benches (e-lounge) to be placed inside the building (R(in)) or outside (R(out));
3. Vehicle (RLO): charging, washing and workshop;
4. Management (M): info point, offices, meeting room (with cloakroom, flipchart, video projector, printer) ticket machine for public transport or panels with QR codes, information panels with tips and points of interest;
5. Wear (W): essentials;
6. Food (F): shelves, counter, Trentino products, bar service/hot meals/ready meals also with possible equipped area (microwave, kettle, sink);
7. Other (A): storage, installations (electrical, fire prevention, heating, cooling, ACS, energy storage, controlled mechanical ventilation);
8. Complementary activities (C): possible
9. Toilets (WC).

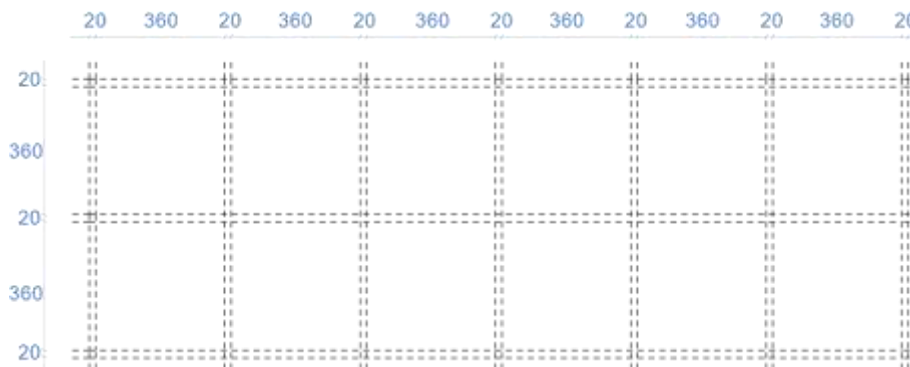


**Figure 15.** Interactions among the activities of the New Building's functional programme.

As the New Building is a demonstrator building, a simple solution was chosen for the shape, which could be combined with different façade element solutions to be monitored and proposed for future new constructions.

The building is designed on a square module with dimensions 3.60m x 3.60m (60 cm being a useful dimension both in terms of usability of the space and furnishing) and with a load-bearing timber frame. Between one module and another there is a space of 20 cm that allows the insertion of vertical elements (pillars) that can have dimensions 20 x L where  $L \geq 20$  cm. The module allows for floors with 3 different types of span: 3.6m - 7.20m - 10.80 m, depending on the type of new technology that will be used. The net floor area is approximately 155 square meters.

The building will have a rectangular plan (**Figure 16**) with short side  $3.60\text{m} \times 2 = 7.20\text{m}$  (plus  $3 \times 0.20$  for the structure) and long side approximately  $3.60\text{m} \times 6 = 21.60\text{m}$  (plus  $7 \times 0.20$  for the structure).



**Figure 16.** Module and construction grid for the New Building.



In elevation, the building will be **two storeys**, each 3m of effective height. Since the total height must be less than 8m as per building regulations, the roof will be flat or slightly sloping. A concrete basement is planned to be used as storage and plant room. The basement walls will also be used for testing the innovative geothermal probes proposed by POLITO in WP6. **Figure 17** shows the schematic sections and of the building.

The schematic functional plans of the New Building are shown in **Figure 18** while **Figure 19** and represents graphically the percentage distribution of the different functional areas.

The modularity in plan allows the available space to be increased if necessary (in plan in both directions but also in elevation), correlating the new parts to the existing structure and installations (thus allowing the scalability of the project and reproducibility in conditions with different requirements).

The load-bearing frame will consist of timber pillars, glulam beams, and innovative large-span wooden floors, inspectable and easily replaceable. St. Andrew's cross seismic dampers will be used.

The envelope will consist of prefabricated wooden walls hanging from the floors (which are protruding from the beams). To the south there will be six innovative prototype walls whose thermo-hygrometric performance will be monitored and compared: *green wall, super-insulated wall, cool wall, ventilated wall, BIPV wall* and *transparent BIPV wall*.

A simple conceptual mass design model was made to perform the initial analysis and design work required at this stage of the design process (**Figure 20**).

From the plant engineering point of view, the building will be equipped with:

1. Multi-source heat pump (aerothermal/geothermal/solar thermal) to exploit and compare the efficiency of the different sources
2. Solar thermal with drop pump connection (SAHP) and probably to cover the minimum demand for DHW
3. Sensible thermal storage (to exploit advanced control logic)
4. PV system (if alternative to BIPV)
5. PV storage batteries (if required)
6. Open control and regulation system (BAS) (useful for data collection but also for regulation and implementation of different strategies)
7. Dry heating system
8. CMV plant with thermodynamic recovery.

Passive heating and cooling techniques such as natural ventilation and envelope thermal inertia will also be implemented.



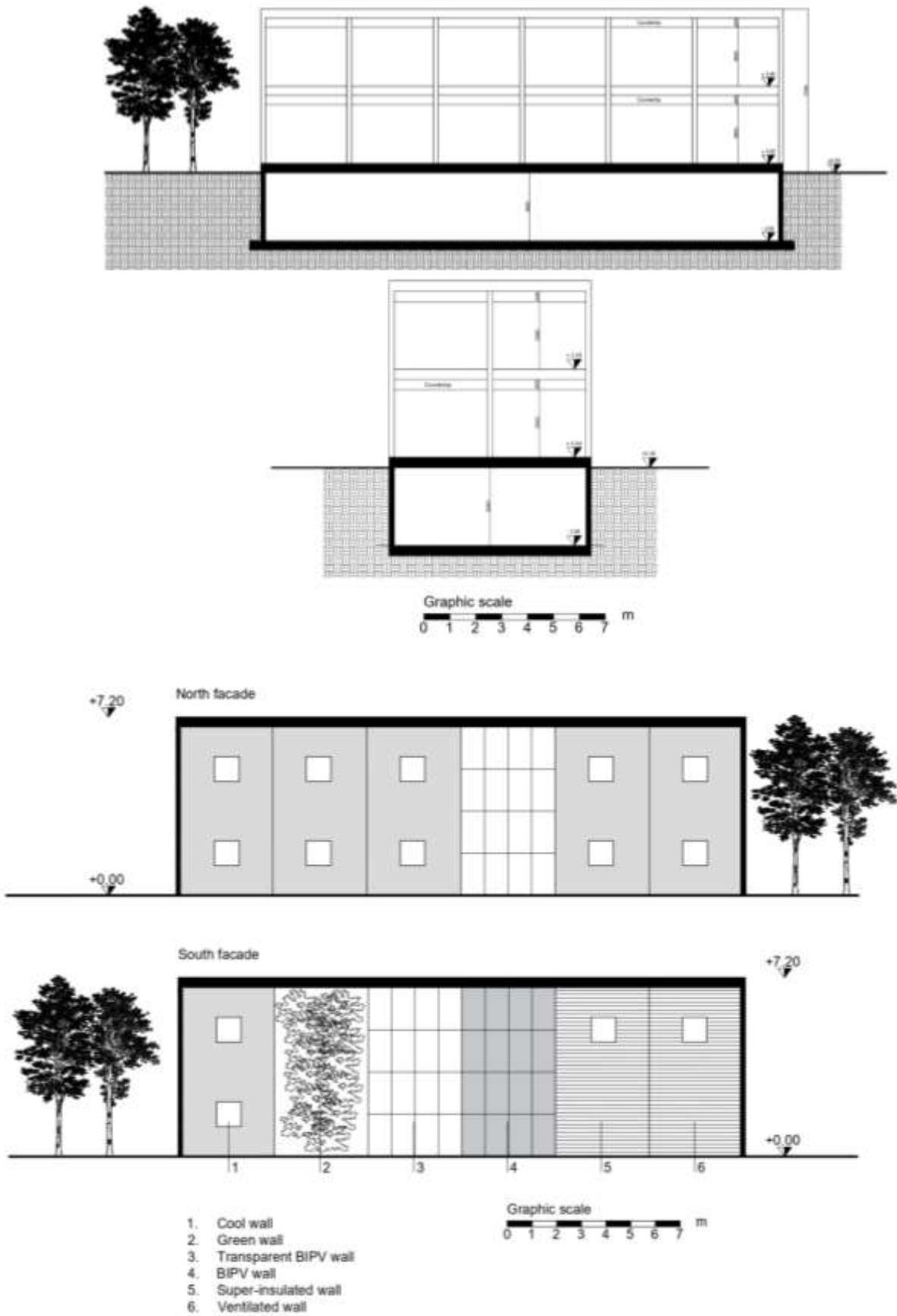


Figure 17. Schematic sections and elevations of the New Building. Source: UNITN.

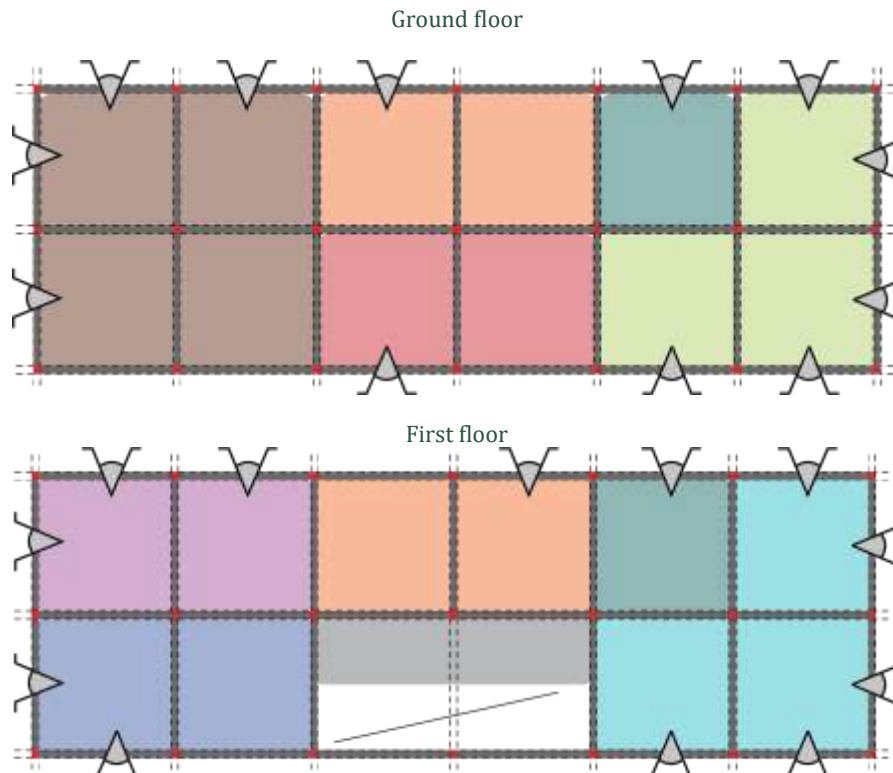


Figure 18. Functional schematic plans of the New Building. Source: UNITN.

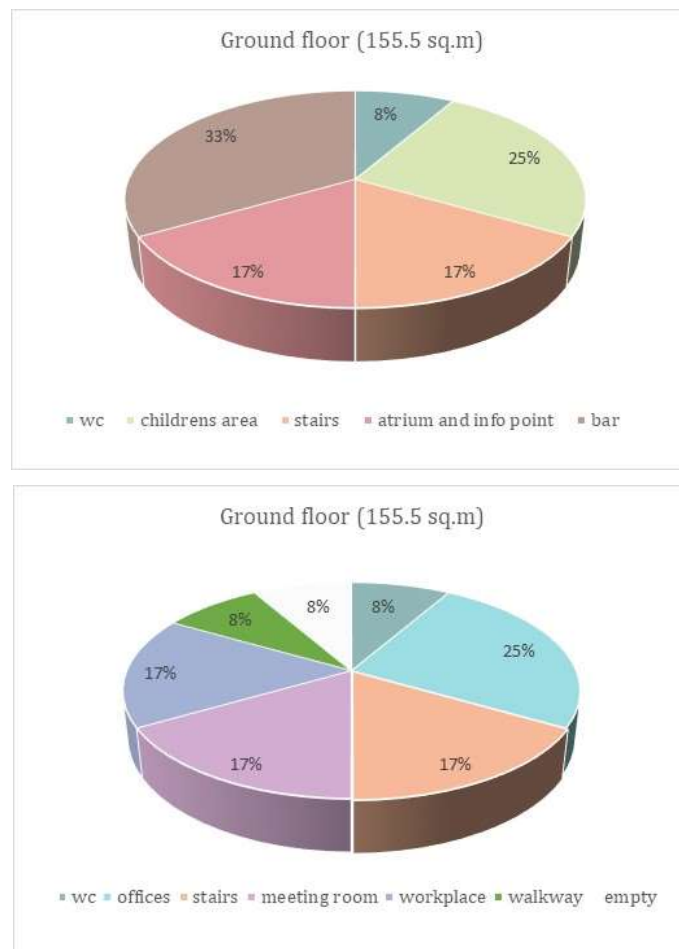
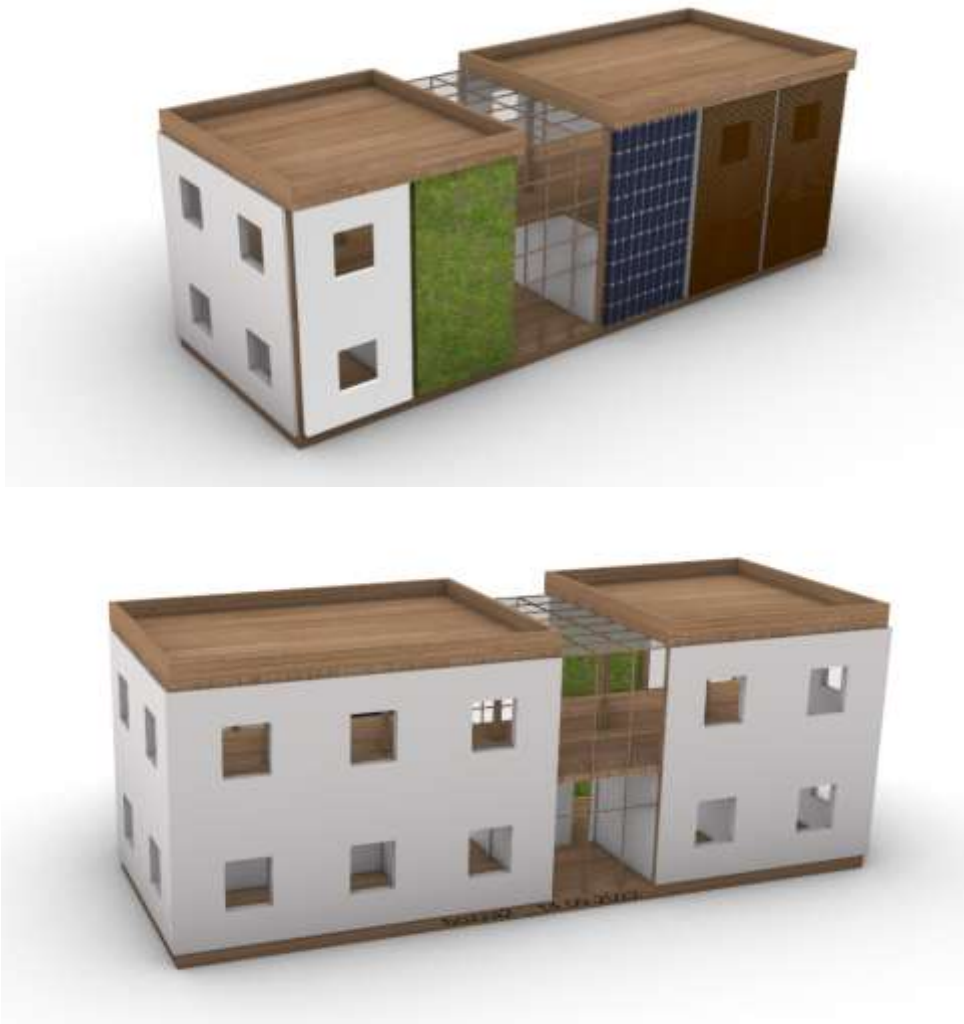


Figure 19. Percentage distribution of the different functional areas for the New Building. Source: UNITN.



*Figure 20. 3D views of the New Building model. Source: UNITN.*

After defining the concept of the New Building, a preliminary cost estimate by applying a synthetic cost procedure has been done.

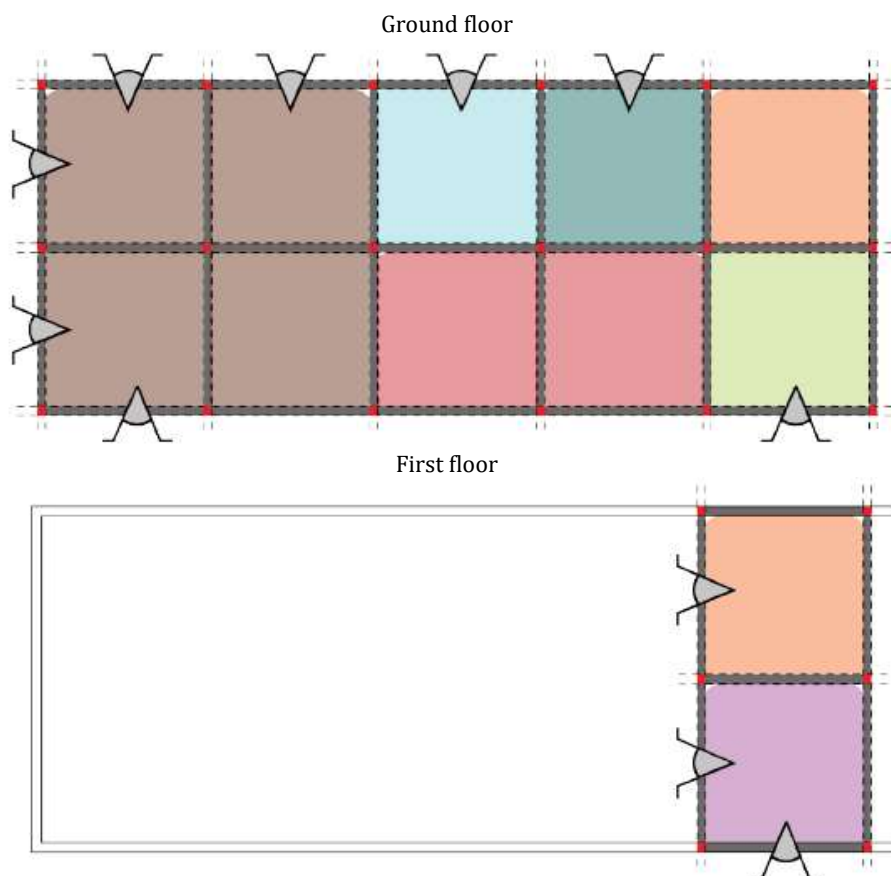
Due to budget constraints (see AMD of the GA), the concept of the New Building has been redefined. In order to reduce volume and area, the number of floors was reduced as well as the length of the building.

The new configuration retains the rectangular floor plan (**Figure 21**) but in the elevation the building functions are located only on the ground floor and no longer on two floors. The stairwell has been moved from its central position at the head of the building to allow access to the roof terrace.

The schematic functional plans of the redefined New Building are shown in **Figure 22** while 3D views are shown in **Figures 23** and **24**.

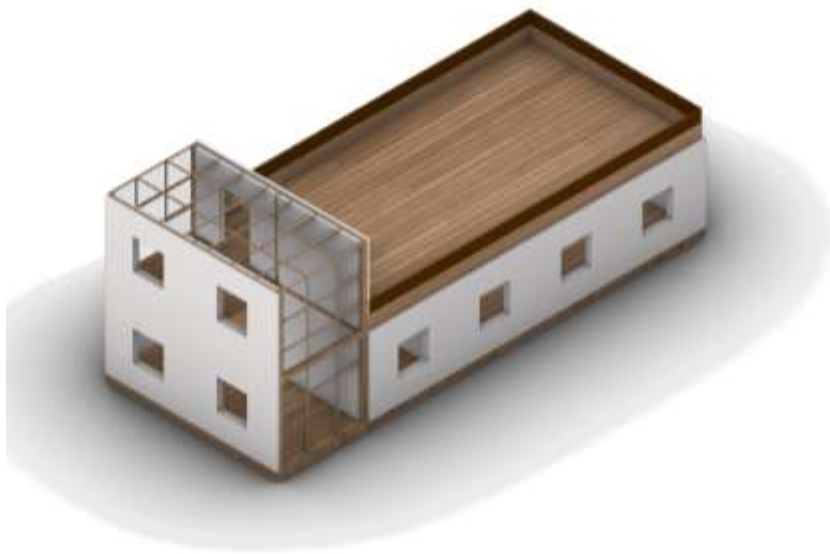
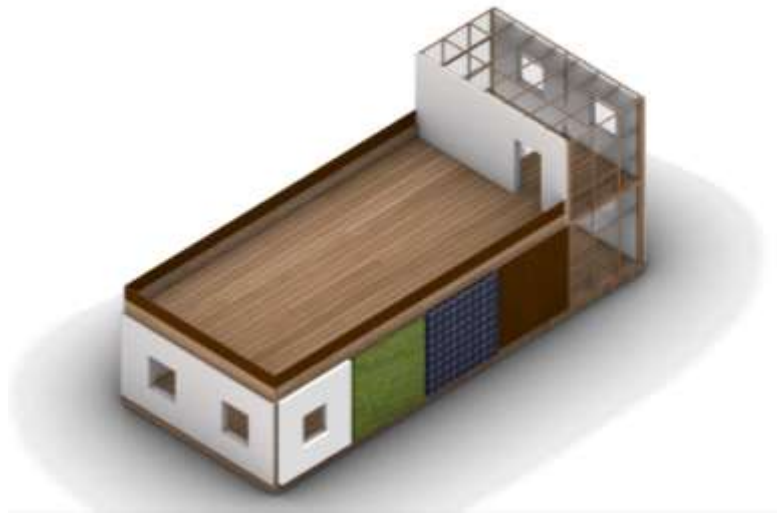


**Figure 21.** Module and construction grid for the redefined New Building. Source: UNITN.



**Figure 22.** Functional schematic plans of the redefined New Building. Source: UNITN.





*Figure 23. 3D views of the redefined New Building model. Source: UNITN.*



*Figure 24. 3D rendering of the redefined New Building. Source: UNITN.*

At a preliminary stage, the following elements were identified for the design of the **ENERGY BUILDING SYSTEMS**:

- *multisource heat pump system* (aerothermal/geothermal/solar thermal) in order to exploit and compare the efficiency of the different sources;
- *solar heating system* with connection to a Solar-Assisted Heat Pump (SAHP);
- *sensible heat storage* to take advantage of advanced control logic;
- *PV system* on the roof and façade-integrated photovoltaics (BiPV only on a façade panel);
- *solar battery systems*;
- an open *Building Automation System* (BAS) for the control, a regulation and data collection;
- *underfloor heating dry low*;
- *mechanical ventilation system with Heat Recovery* (MVHR).

In order to pursue the goal of a New Positive Energy Building, an **ENERGY PRELIMINARY STUDY** has been carried out. On the basis of the ECD of New Building, various scenarios on the building energy requirements and energy exchanges with the electricity grid were analysed. The assumptions adopted, the calculation method and the main results obtained are summarised in the **Annex 9.3.6\_Preliminary analysis energy demand for the New Construction**".

The preliminary analysis of the building's energy demand for air conditioning, ventilation and lighting showed the following conclusions under the assumption of alternative operation of geothermal (GSHP) and aerothermal heat (ASHP) pump:

- in the case of geothermal heat pump system (GSHP), the building has a positive balance (puts more into the grid than it takes out on an annual basis) with 7 (scenario 1) and 10 (scenario 2) rooftop PV modules regardless of the transparency characteristics of the BiPV façade.
- In the case of aerothermal heat pump (ASHP), at least 10 rooftop PV modules are required to achieve a positive balance.
- The transparency characteristics of the BiPV facade have a slight impact on the balance the building. In general, given the characteristics of the climate, the beneficial effect of the greater amount of solar gains in the winter months on the greater cooling loads prevails in the balance.

## 5.2 DESIGN DEVELOPMENT

This is the phase where the design intent manifests as a detailed plan. The Design Development (DD) phase executes the ECD phase and further refines the details that were initially established in the schematic design phase. In fact, it is important to finalize the details of the ECD before moving into the next phase (DeD) that is preparatory to construction.

The Design Development (DD) develops the basic materials for all elements of the building, including the structure, envelope and interior completing also the definition and integration of all systems. The DD contributes the definition of a more realistic cost estimate.

The final product of the DD is the result of a participatory design process. This chapter briefly describes the *procedures and stakeholders involved, the architectural, environmental, social, economic goals and the strategies and solutions pursued.*

### 5.2.1 PROCEDURE AND STAKEHOLDERS INVOLVED

The Design Development (DD) involved the same procedure and stakeholders of the ECD phase. Information, consultation, and collaboration among stakeholders took place through meetings. Participants, dates, locations, and topics discussed are listed in the "Table of Meetings with Stakeholders" (see **Annex 9.3.7\_ Table Meetings STAKEHOLDERS\_NC\_DD**).

The design proposal developed during the DD phase is the result of continuum interaction among the different technical figures involved, with the aim of promoting a sustainable building without imbalances among the disciplines involved (envelope and materials, systems, structures, etc.).

The outcomes of the DD phase were presented and shared with the citizens of Piedicastello at the public meeting held on 27/10/2023 (**Figure 25**).



**Figure 25.** Public meeting, 27.10.2023. Photo: UNITN.

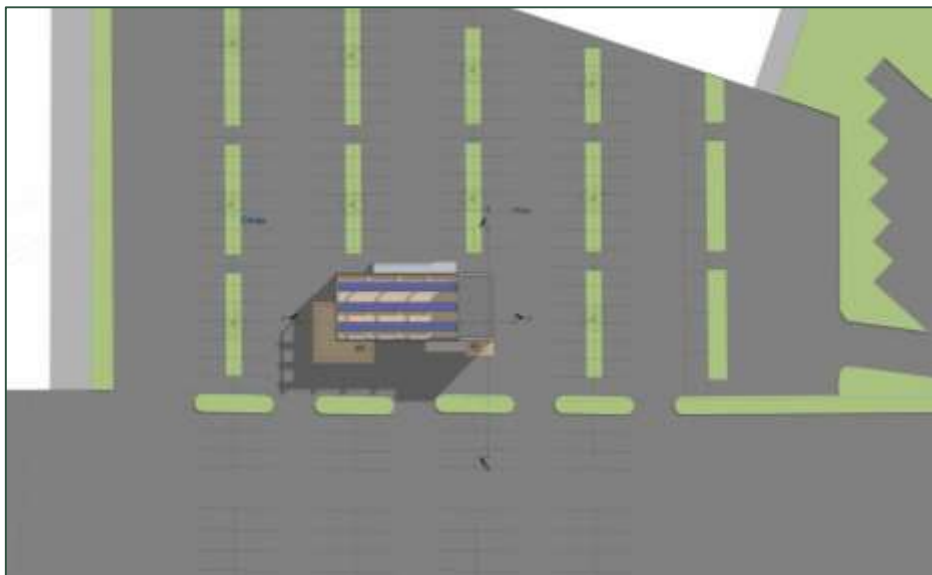
## 5.2.2 ARCHITECTURAL, ENVIRONMENTAL, SOCIAL, ECONOMIC GOALS (WHAT, WHY, WHO, HOW)

The goals of the solutions proposed for the New Building are:

- to build a **POSITIVE ENERGY BUILDING** that is experimental and demonstration for the Community;
- to build a **TIMBER BUILDING** with nature-based and low environmental impact solutions and with a circular perspective;
- to integrate **PASSIVE SYSTEMS** (ventilated façades, active thermal mass, natural ventilation) and active systems (photovoltaics, combination of mechanical ventilation and geothermal heat pumps, also with connection to an energy geostructure).

## 5.2.3 STRATEGIES AND SOLUTIONS

In this design phase, the verification of all regulatory aspects regarding the New Building was completed in order to achieve a shared design with authorities and subjects responsible for verification and control. Conceived as a regular modular structure, the volume of the New Building is realised by means of innovative wooden and dry technologies that can be fully disassembled. **Figure 26** shows the location of the building in ex Zuffo parking lot.



*Figure 26. Design layout. Source: ARMALAM.*

The architecture of the New Building consists of a combination of cubic modules forming a simple volume with a rectangular base with two above-ground levels (H= 8m) and a basement. Plans, sections and elevations of the DD are shown below. In particular:

- the **basement** is used for storage ( $66.8 \text{ m}^2 + 53.7 \text{ m}^2 = 120.5 \text{ m}^2$ ) accessible through the internal stairwell and an external staircase located on the north side (**Figure 27**);
- the **ground floor** consists of the entrance hall ( $15.2 \text{ m}^2$ ) and the main services offered by the HUB such as the info-point area ( $28.9 \text{ m}^2$ ), the bar area ( $48.2 \text{ m}^2$ ), the bar depot ( $6.3 \text{ m}^2$ ), the office/children's area ( $14.2 \text{ m}^2$ ) and the toilets ( $2.7 \text{ m}^2, 3.8 \text{ m}^2, 1.5 \text{ m}^2, 3.7 \text{ m}^2, 3.6 \text{ m}^2 = 15.3 \text{ m}^2$ ) (**Figures 28**);
- the **first floor** is a terrace accessible via the internal covered staircase (**Figure 29**) and partially shaded by a pergola that can be used for the installation of photovoltaic modules (**Figure 30**).



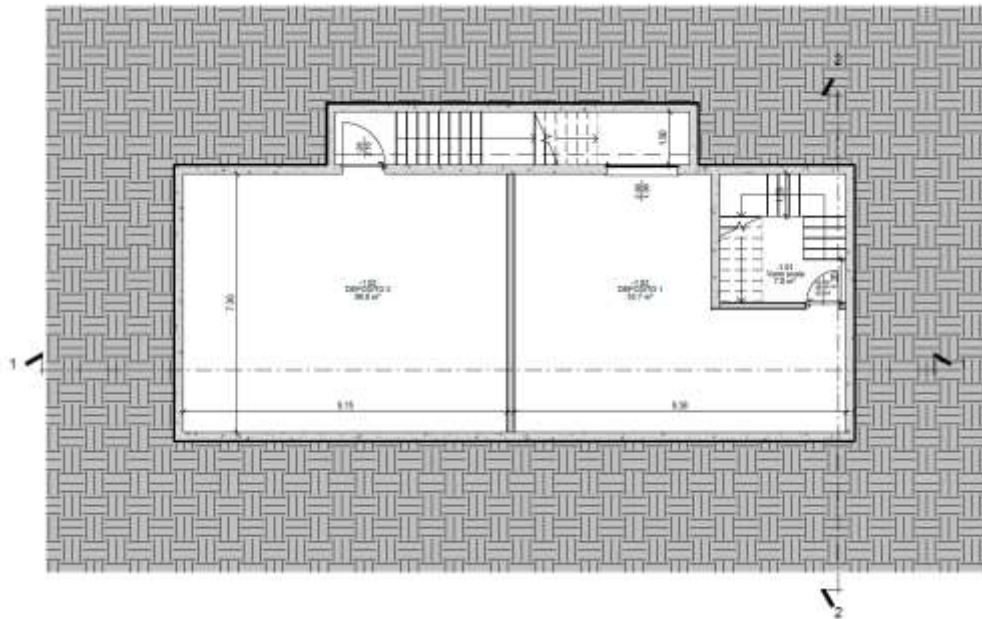


Figure 27. Basement plan. Source: ARMALAM.

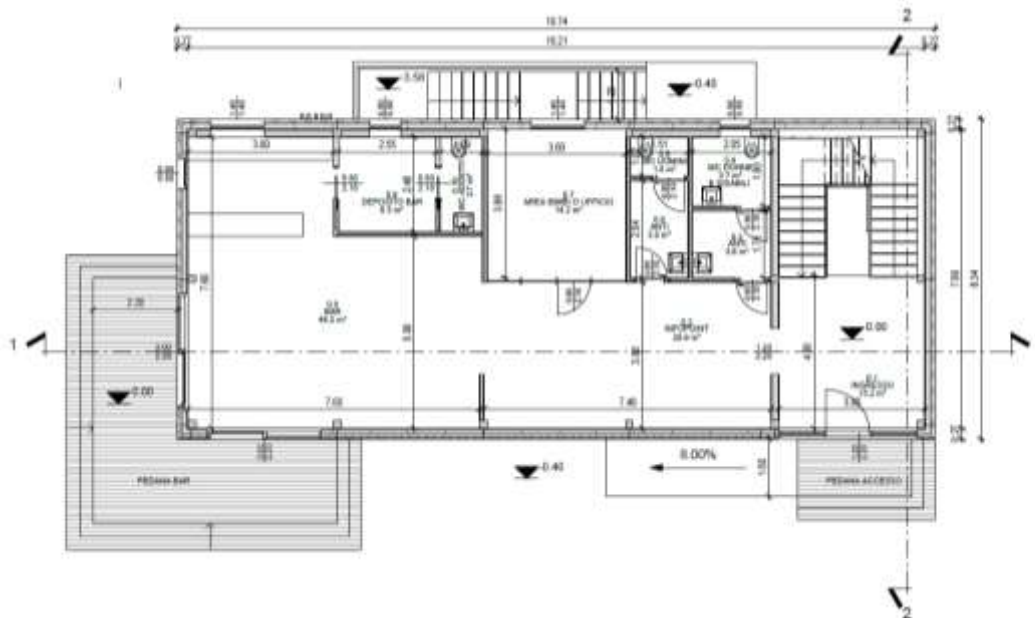


Figure 28. Ground floor plan. Source: ARMALAM.

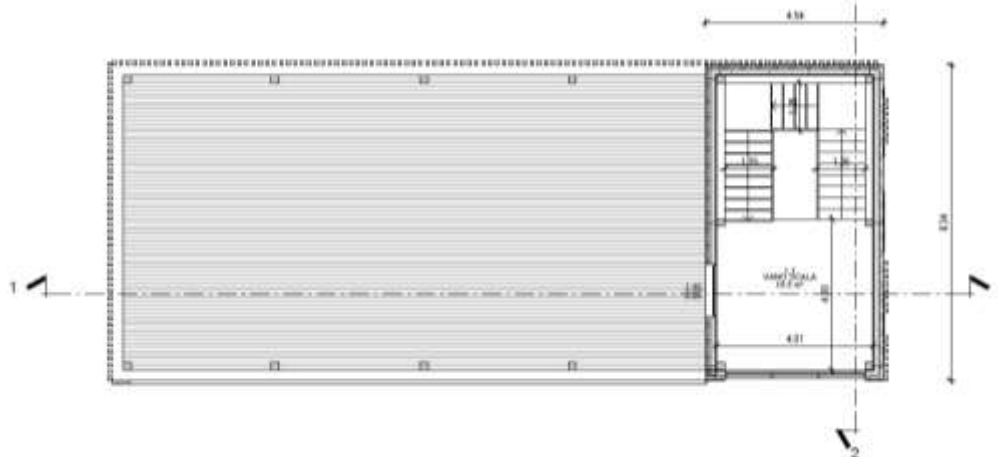


Figure 29. First floor plan. Source: ARMALAM.

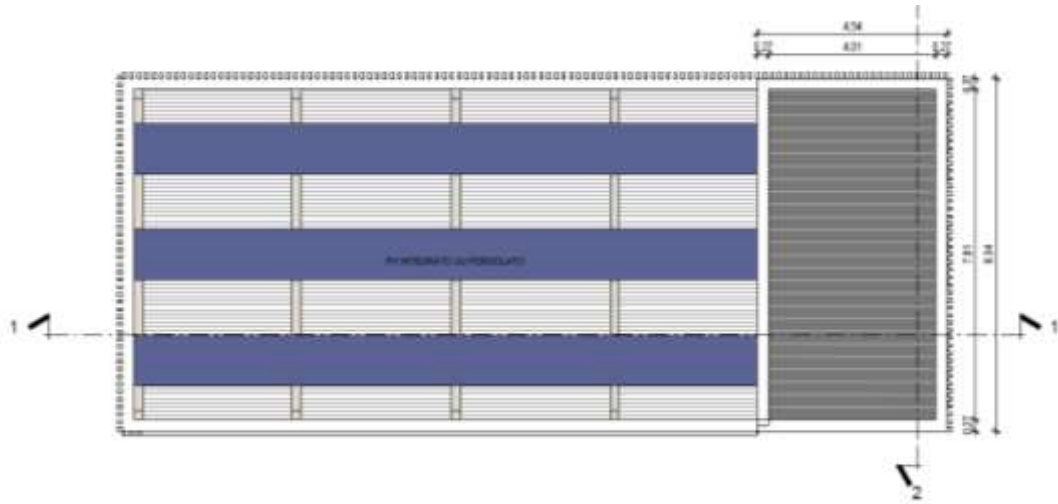


Figure 30. Roof plan. Source: ARMALAM.

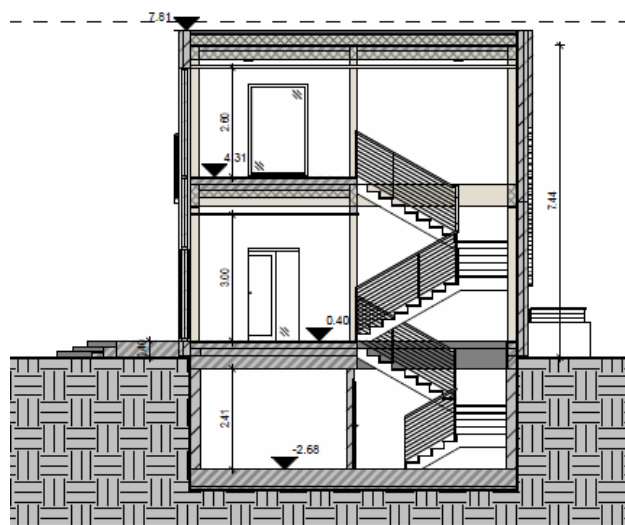
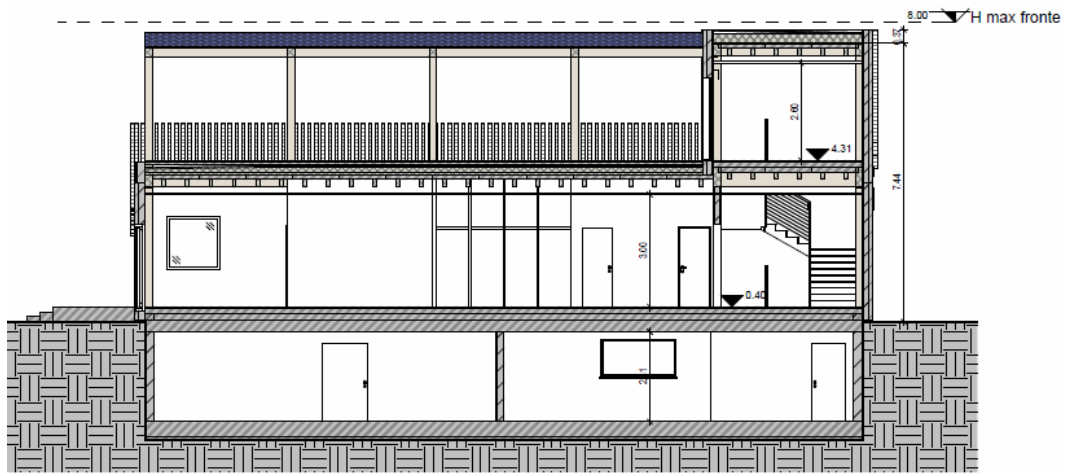
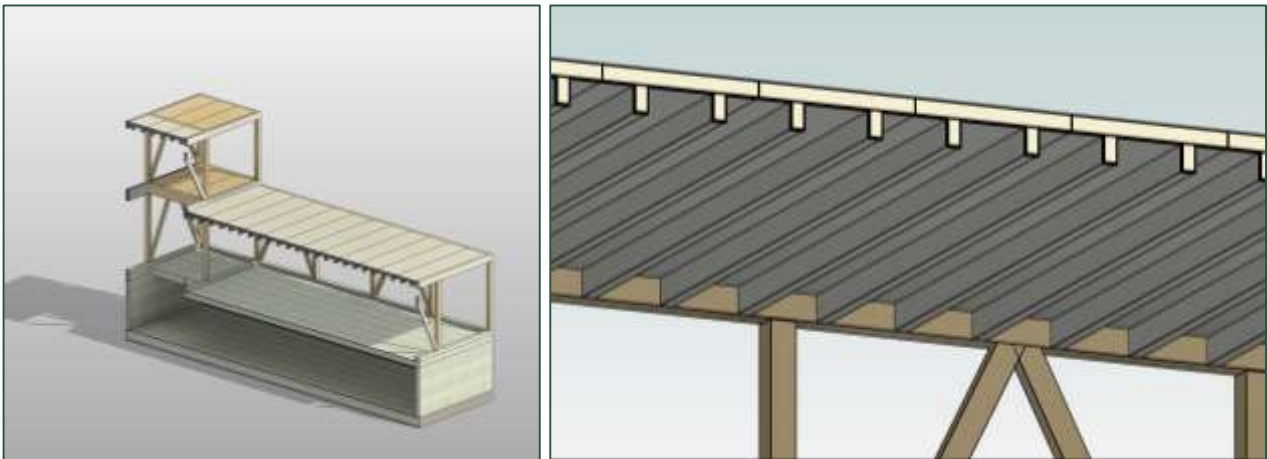
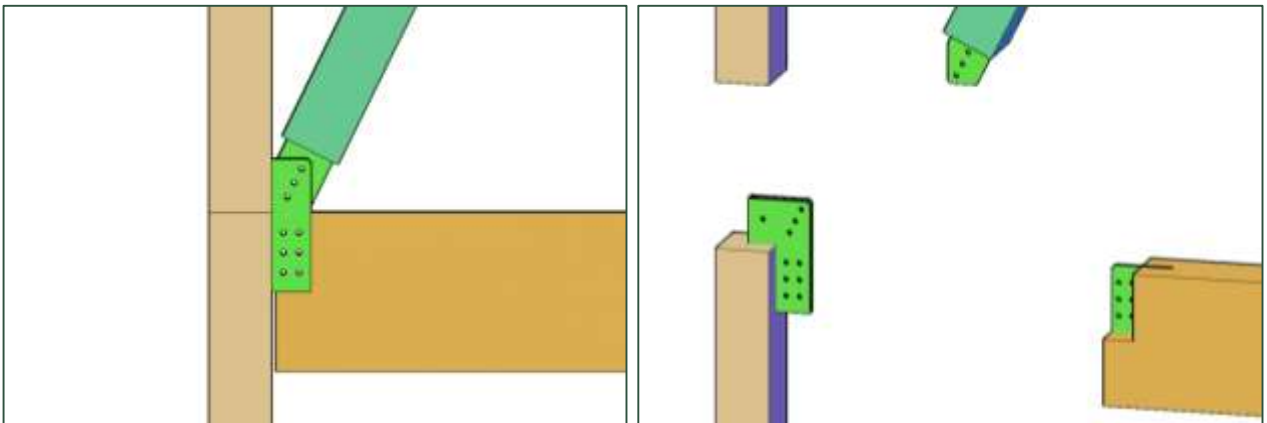


Figure 31. Section 1-1 and Section 2-2. Source: ARMALAM.

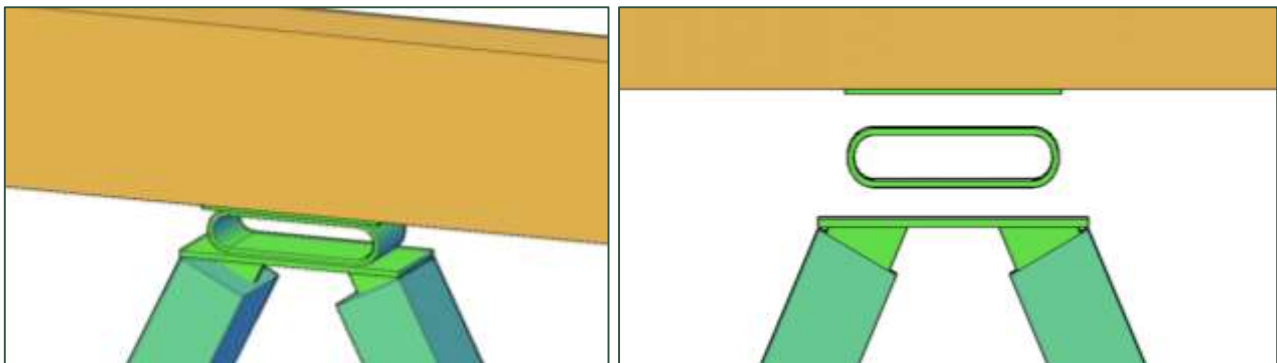
The New Building is mainly based on a load-bearing timber frame for the above-ground levels and a basement with walls and continuous foundations in reinforced concrete. The slab separating the basement from the ground floor is of solid reinforced concrete to ensure adequate fire compartmentation. The aboveground volumes, given the need to protect the timber structures, are raised from the level of the area by approximately 40 cm. Consequently, pedestrian accessibility to the raised ground floor is ensured by means of timber platforms and a suitable ramp with a longitudinal slope of less than 8%. The **load-bearing structure** is made of glulam and CLT panels PEFC and/or FSC certified. In particular, the roof slab consists of prefabricated CLT ribbed slab with R60 fire resistance (**Figure 32**). The connections of the timber elements are with internal steel plates that are glued to the load-bearing structures during production (**Figure 33**). The metal connection elements that will remain exposed will be adequately protected to ensure the same fire performance as the structures. **Figure 34** shows the dissipative node of the innovative bracing system implemented in this project.



**Figure 32.** Load-bearing glulam timber frame and CLT panels for the New Building and the prefabricated ribbed timber floor system for the roofs. Source: ARMALAM.



**Figure 33.** Steel plates for the connection of timber elements, bonded to the load-bearing structures during production. Source: ARMALAM.



**Figure 34.** Dissipative node of the innovative bracing system. Source: ARMALAM.

The **building envelope** consists of innovative prefabricated multifunctional timber-frame façade elements (PMTF), designed both for new construction and for the improvement of existing buildings in terms of energy efficiency, interior comfort and architectural features. More information on this solution called “Renew Wall system” can be found in the section 6.1.3 of this document and in Chapter 3 of D.5.2 of the ARV project.

For the integration of PV in the architecture design, the designers followed the Design Guidelines developed by the DAD (Department of Architecture and Design) research group of POLITO for the Demo Project in Trento. This document, which classifies integration categories and includes solutions and reference projects, supported the development of the envelope design (see **Annex 9.3.8\_Design guidelines for the integration of PV in architectural design**).

The **south façade** includes the access to the building and **5 innovative façade solutions** whose performances will be monitored throughout the duration of the research project. The solutions are:

- 1) *Renew Wall panel with "light earth" colored plaster finish,*
- 2) *Renew Wall panel with matt PV coating finish,*
- 3) *Renew Wall with ventilated façade finish,*
- 4) *Renew Wall panel with green finish,*
- 5) *Curtain wall with integrated PV.*

In addition, the south façade is characterized by the installation of parapets with integrated PV modules in the terrace. **An innovative insulation material for the walls** has been proposed. The proposed insulation called “CARTONLANA” consists of 100% sheep's wool panels, a natural, innovative, recyclable product with excellent sound absorption and insulation performance. This insulation is the result of a research project carried out by DAVIFIL in collaboration with CNR ISMAC in Biella and POLITO-DAD.

In addition, the possibility of incorporating in the south façade the innovative PVT system described in Report 9.1 of the ARV project was evaluated and discussed.

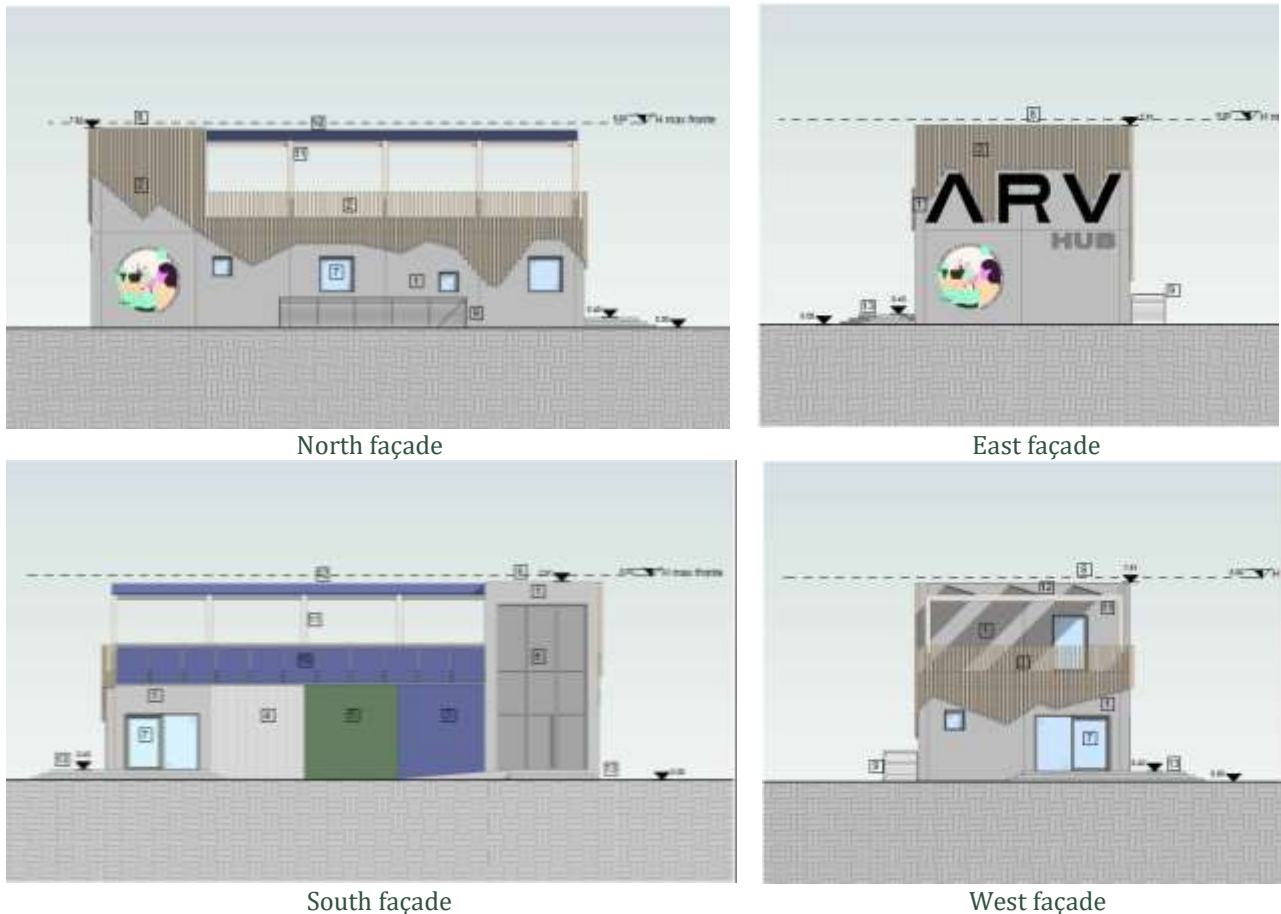
The east, west and north façades are composed of the Renew-Wall system with a 'light earth' plaster finish. In order to vary the uniformity of the building given by the regular and repetitive volumes, the designers introduced an external cladding with wooden vertical battens with the dual function: serve as a terrace railing and create a reminder of the alpine territory in which the HUB is located recalling the skyline of the mountains on its external façades (**Figure 35**).

The flat roof of the staircase volume is made of light grey sheet metal and all the sheet metal work is also of the same colour.

The windows and doors are triple-glazed with high thermal-tightness frames with a grey aluminium finish on the external side. These will be equipped with an automated shading system with external adjustable metal slats.

In accordance with the current Italian regulations on accessibility and removal of architectural barriers in private and public buildings (without the obligation to hire of disabled persons) the design guarantees access to the building and outdoor spaces, the visitability of spaces open to the public, and at least one toilet reserved for disabled persons. The staircase envisages the possibility of installing a stair lift for access to the terrace. A careful design of the equipment and furnishings of the New Building will guarantee adequate usability of the spaces.





**Figure 35.** Elevations (North, East, South and West), and external finishes of façade Source: ARMALAM: 1) Renew Wall panel with "light earth" colored plaster finish, 2) Wooden battens, 3) Renew Wall panel with matt PV coating finish, 4) Renew Wall with ventilated façade finish, 5) Renew Wall panel with green finish, 3) 6) Curtain wall with integrated PV, 7) Triple glazed windows with grey aluminium external finish, 8) Light gray sheet metal covering, 9) Grey metal railing, 10) Railing with integrated PV, 11) Timber pergola, 12) PV integrated on pergola, 13) Wooden platform. Source: ARMALAM.

The air-conditioning system is characterized by a hydronic equipment (for heating and cooling of fan coils) with separated spot mechanical ventilation systems installed close to the window frames. This divides the air-conditioning (secondary ventilation) from the ventilation service (primary ventilation), the latter only supplying primary air. Similarly, a dedicated heat pump with a small water storage system will provide the domestic hot water (DHW), given the limited consumption due to the intended use.

The emission terminals for heating and cooling are fan coils partially recessed in the wall, thus optimizing the pipe passages by advancing the prefabrication level and reducing construction time while ensuring optimal system efficiency.

The generation system consists of an innovative multi-source heat pump, which can alternatively use air or water from the geothermal plant as a source. The main idea is to make available to the reversible HP a stable high-temperature source or low-temperature sink in heating and cooling respectively. For this reason, the choice of source will be studied using different regulation logics in order to maximize the system's performance while meeting the constraints on closing the annual energy balance of the source/sink. The multi-source heat pump is an inverter-driven heat pump dedicated to heating and cooling operations. The heated or cooled water is initially fed to a buffer storage that will reduce the on/off cycles of the heat pump. Moreover, the buffer storage tank is also used for testing advanced control logic that can maximize the self-consumption of photovoltaic energy. For this, the system will be equipped with energy meters, as well as monitoring of the electricity produced by the photovoltaics. Then, a sufficiently large dataset of measurements will be collected to train machine learning models that are subsequently used to test predictive control logics. Initially, however, the measures will be used to test rule-based adjustments. For example, the frequency of the inverter will be adjusted so that the



which integrates not only the production of electricity, but also heats up indoor air, thus providing an additional contribution to secondary air conditioning system. The latter component will also be integrated into the façade, ensuring an excellent level of prefabrication as well as integrating plant components into the envelope. The performance of this façade will be monitored and will also be used to validate its effectiveness as a retrofit solution for existing buildings.

During the DD phase, the architectural and structural model of the building was also refined. **Figure 37** showcases some realistic views of the building through rendering different views.



*Figure 37. Exterior 3D renders of the New Building in ex Zuffo parking lot. Source: ARMALAM.*

## **5.3 DETAILED DESIGN**

---

In this next phase of the design process, design becomes a reality. The result of this phase is the complete and precise physical description of all the parts in the building final product. The DeD serves as the basis for the construction phase.

### **5.3.1 PROCEDURE AND STAKEHOLDERS INVOLVED**

### **5.3.2 ARCHITECTURAL, ENVIRONMENTAL, SOCIAL, ECONOMIC GOALS (WHAT, WHY, WHO, HOW)**

### **5.3.3 STRATEGIES AND SOLUTIONS**

Actions to be implemented in the next year

## **5.4 SUMMARY**

---

### **5.4.1 ARCHITECTURAL QUALITIES**

### **5.4.2 SOCIAL QUALITIES**

### **5.4.3 ENVIRONMENTAL SUSTAINABILITY**

### **5.4.4 ECONOMIC FRAMEWORK**

Actions to be implemented in the next year

## **5.5 DESIGN REPLICABILITY AND TRANSFERABILITY IN THE URBAN AREA**

---

### **5.5.1 OPPORTUNITIES**

### **5.5.2 CHALLENGES**

### **5.5.3 STRATEGIES AND SOLUTIONS**

Actions to be implemented in the next year



## 6. DESIGN OF EXISTING BUILDINGS REFURBISHMENT

The Refurbishment for the Trento demonstration project is a residential building (hereinafter referred to as the Existing Building) located in Povo District, 4 km from Piedicastello (**Figure 38**).

The initial proposal to focus the renovation on ITEA's residential buildings located in the Piedicastello District could not be pursued due to the withdrawal of the ITEA supporting partner from the ARV project. Consequently, the project proposed an alternative 3-floor apartment building.

The Existing Building, located in Pantè Street n.2 (46°04'01.13"N 11°09'18.11"E, 398 m a.s.l.) and therefore named "Condominio Pantè", consists of 9 housing units, private own and built during the '50s. It is T-shaped with a hipped roof. Balconies are present on the north-east elevation façade and south-west façade (**Figure 39**).



*Figure 38. Overview of Povo district. Source: UNITN.*





**Figure 39.** Overview of the residential Existing Building in Povo District. Source: Sovercar Srl.

The main structure is a brick block bearing wall construction not insulated, with a U value of the envelope quite high ( $U=1.81 \text{ W/m}^2\text{K}$ ). The roof is a timber construction with a non-heated and uninhabitable attic. Heating system is made of individual gas boilers for each apartment with radiators as distribution system. Some more data:

- Gross volume of the habitable parts of the building (V): 203.04 m<sup>3</sup>;
- Dispersing surface area bounding the heated volume (S): 162.51 m<sup>2</sup>;
- S/V ratio (form factor): 0.80 m<sup>-1</sup>;
- Useful heated area of the building: 43.60 m<sup>2</sup>.

## 6.1 EARLY CONCEPT DESIGN

The Early Concept Design (ECD) of the Existing Building refers to:

- a) the **evaluation phase of retrofit scenarios** (aimed at reducing ENERGY CONSUMPTION towards the concept of Nearly Zero Energy and Positive Buildings, improving the living comfort of users, optimising economic resources, reducing the environmental impact of the construction site, etc.)
- b) the **general planning phase** (aimed at defining the REFURBISHMENT PROGRAMME AND MONITORING PROGRAMME)
- c) the **technical-economic feasibility of the interventions of the energy design** (aimed at defining the costs of the building interventions).

The final product of the ECD is the result of a participatory design process. This chapter briefly describes the *procedures and stakeholders involved, the architectural, environmental, social, economic goals* and the *strategies and solutions* pursued.

### 6.1.1 PROCEDURE AND STAKEHOLDERS INVOLVED

EURAC and UNITN started the participatory design process for the Existing Building refurbishment. Subsequently, the design process was developed with the collaboration of the other ARV partners which are HABITECH and the third-party manufacturing companies. Other external stakeholders involved in the ECD phase were the Users (**Table 6**).

All stakeholders contributed directly or indirectly to the development of the ECD of the Refurbishment. The activities dealt with the analysis of the context, the knowledge of the building and the definition of refurbishment interventions.

Information, consultation, and collaboration among stakeholders took place through meetings (**Figure 40**). Participants, dates, locations, and topics discussed are listed in the "Table of Meetings with Stakeholders" (see **Annex 9.3.9 \_Table Meetings STAKEHOLDERS\_REFURBISHMENT**).

**Table 6.** List of stakeholders of the Design of the Refurbishment.

	CATEGORIES	GROUPS	KEY PERSONS	LIFE CYCLE PHASES
INTERNAL ACTORS belonging to the ARV partnership	UNIVERSITY	UNITN (DICAM)	proff. R. Albatici, A. Frattari, M. Dalprà proff.M. Piazza, I. Giongo, proff.P.Baggio, A. Prada proff.G. Massari	Design (ECD, DD, DeD)
	RESEARCH UNIT	EURAC	dott. D. Vettorato dott. G. Grazieschi	Design (ECD, DD, DeD)
	ENERGY AND ENVIRONMENT DISTRICT	HABITECH	dott. M. Curci dott. A. Fronk	Design (ECD, DD, DeD) Production Construction
	MANUFACTURING COMPANY	HABITECH (FANTI LEGNAMI S.R.L.)	M. Fanti Arch. G. Zini	Design (ECD, DD, DeD) Production Construction
EXTERNAL ACTORS not belonging	MANUFACTURING COMPANY	SOVECAR Group	Dott. M. Giglioli D. Zucal	Design (ECD, DD, DeD) Production Construction
	ENERGY DESIGNER	LEVA S.R.L	Ing. M. Paoli	(DeD)
	USERS	Residents of the building	Cond. Administrator Users/inhabitants	Design (ECD, CD, DD) Use



**Figure 40.** Technical meetings on site 05.07.2023 and 19.09.2023 with inhabitants. Source: UNITN.

## 6.1.2 ARCHITECTURAL, ENVIRONMENTAL, SOCIAL, ECONOMIC GOALS (WHAT, WHY, WHO, HOW)

The goals of the solutions proposed for the REFURBISHMENT of the Existing Building

- to achieve energy and IAQ high standards in both summer and winter through the application of a modular system of Prefabricated Multifunctional Timber-framed Façade (PMTF) and through the integration photovoltaic panels, ventilation machines and solar radiation control systems;
- to implement interventions and measures directly and indirectly affected by tax benefits of various kinds (e.g. Superbonus 110%, etc.);
- to obtain non-invasive, cleaner and tidier construction site that minimises times, production waste, noise and possible problems related to installation;
- to increase the economic value of the housing units of the building;
- to define a monitoring activity to assess the building performances in relation to ARV project objectives.

## 6.1.3 STRATEGIES AND SOLUTIONS

The integrated design process with stakeholders produced the definition of the REFURBISHMENT PROGRAMME and MONITORING PROGRAMME.

Strategies and solutions have been proposed and pursued to take advantage of the Superbonus 110%. The Superbonus 110% is a measure to finance the energy and seismic renovation of residential buildings. This was introduced by legal decree n.34/2020 art. 119 and 121, undergoing many changes over time which essentially concern the procedure for the assignment of the tax credit and the extension of the terms for carrying out interventions. The interventions allowed to take advantage of the tax deductions concern works that are part of civil engineering to increase the energy efficiency of the building and to allow the reduction of the seismic risk. The interventions provided for by the Superbonus 110% can be summed up in two macro areas: “towing” and “towed”.

The “**towing**” interventions are:

- *Energy efficiency interventions* that allow the building to increase by two energy classes with thermal insulation (thermal coating) of opaque dispersive surfaces (vertical, horizontal or oblique) affecting the building’s thermal envelope with an incidence greater than 25%. This applies to condominiums, single-family and multi-family buildings.
- *Interventions on shared parts of the condominium building relating to the replacement of winter air conditioning systems* with centralized systems for heating and/or cooling and/or the supply of domestic hot water via condensing boiler, with an efficiency at least equal to class A. This applies only to condominiums.
- *Interventions on single-family buildings to replace winter air conditioning systems* with systems for heating and/or cooling and/or the supply of condensing domestic hot water units, with efficiency at least equal to class A. This applies to single-family or multi-family buildings with independent access.
- *Anti-seismic operation and reduction of seismic risk.*

The “**towed**” interventions are:

- *Additional energy efficiency measures* (not included in “towing” interventions) covered by the ECOBONUS (e.g. the replacement of the windows), the installation of photovoltaic panels and related storage systems (batteries).
- *Installation of charging stations for electric vehicles.*
- *Interventions of elimination of architectural barriers* for persons with disabilities in a serious situation and for people over the age of 65 years old.

The “towed” interventions are eligible if performed with at least one of the “towing” ones.

For the Existing Building it was not necessary to reduce the seismic risk, but only improvement of energy efficiency.



In order to renovate the building envelope to increase its energy performance (according to the Italian law legal decree n.34 / 2020 art. 119 and 121, and the Legislative Decree 19 August 2005, n. 192) there are mainly two alternatives:

- **traditional:** application of a thermal coat usually outside the envelope (vertical walls, first and last slab so to define a thermal closed box) using scaffoldings all around the building, with replacement of windows with higher-performance ones and a new heating systems (usually new gas condensing boilers, preferably hybrid ones), sometimes in combination with a mechanical ventilation system (if feasible);
- **industrialized:** application of a light prefab modular facade (steel or timber based) on the vertical walls without scaffoldings, complete of new windows, shutters and systems facilities (as NVS for example).

Considering the needs of the inhabitants, times and economic constraints, a hybrid solution has been chosen, i.e. the application of a light prefab modular facade timber based, the insulation of first and last slab with traditional insulation panels, the substitution of gas boilers with condensing ones (3 of them hybrid), the replacement of all windows but not already included in the timber panels, while no MVS has been applied in the apartments.

### **REFURBISHMENT PROGRAMME**

The REFURBISHMENT PROGRAMME for the Existing Building presented and discussed with the Users, is contained in the **Annex 9.3.10\_Annex\_Refurbishment programme**. It includes the thermal insulation of the building envelope, the replacement of windows, doors and boilers, the installation of photovoltaic panels on the roof, and the economic framework of the interventions.

The proposed solution for the thermal insulation is the application of Renew Wall system to be compared with a traditional insulation system. Renew Wall system consists of PMTF façade elements to improve existing buildings in terms of energy efficiency, indoor comfort, and architectural features.

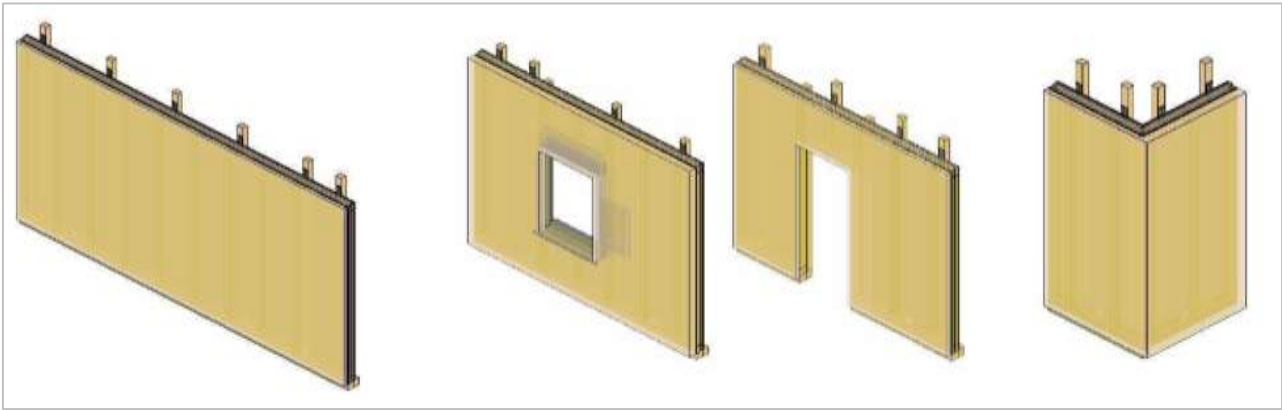
The Renew Wall system has been developed by a local company, Fanti Legnami Srl (Malosco, TN). This company has many years of experience in the production of timber frame walls. This system has been designed, prototyped, and tested from a technical-economic, productive, and executive point of view, but also considering performance, sustainability, and safety.

The Renew-Wall system includes four different types of panels (**Figure 41**). The Renew Wall panels consist of a fixed part and a variable part (**Figure 42**).

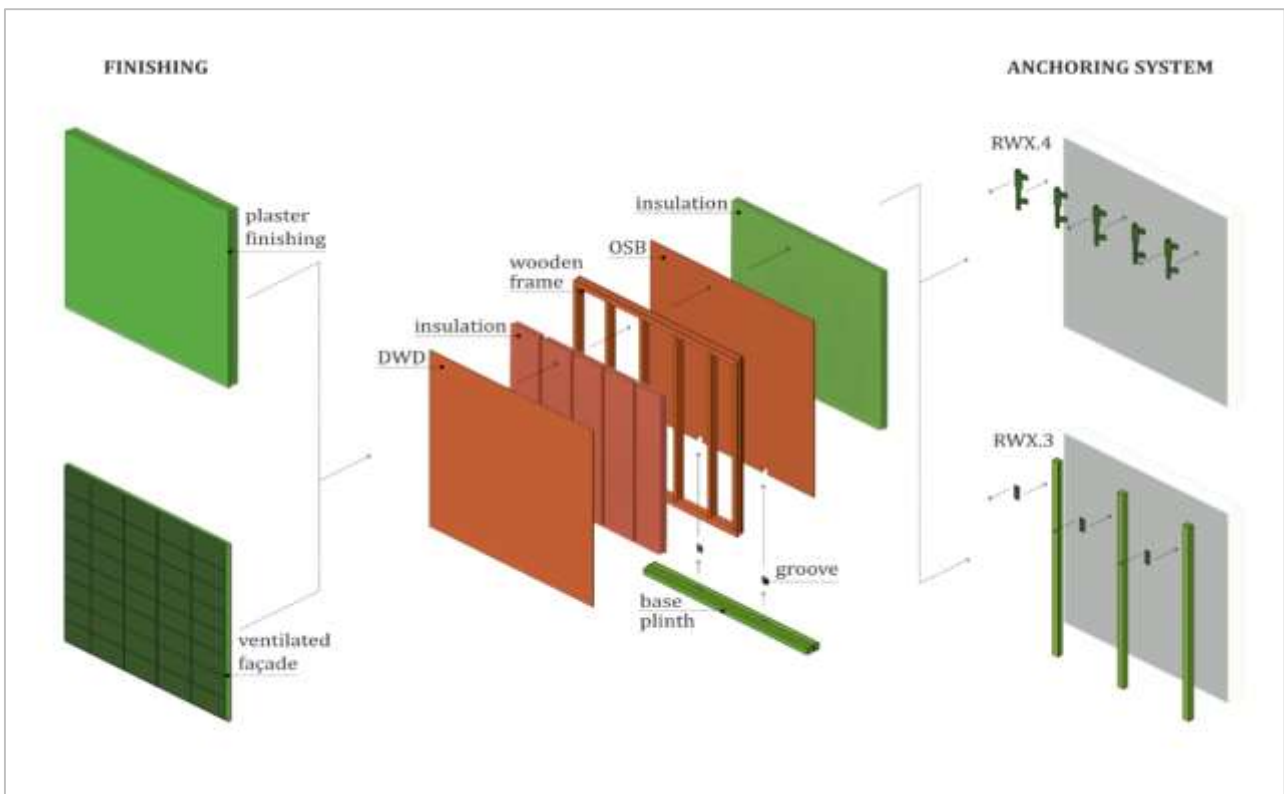
The fixed part includes a wooden frame consisting of two horizontal elements placed at the lower and upper ends and vertical elements placed at regular intervals; the number of vertical elements is variable depending on the width of the panel. An insulation layer is placed between the vertical elements. The wooden frame is braced by an OSB panel on the inner side and a DWD panel on the outer side to enable the creation of a package that is more vapor closed to the inside and more open to the outside.

The variable part concerns: i) the finishing layers on the outer side of the panel for which the designer and the client can choose from several alternative solutions (e.g. insulation + plaster or ventilated wall, etc.); ii) the finishing layer on the inner side of the panel, consisting of soft insulation with variable thickness depending on the geometric irregularities of the surface to be covered. In addition, the Renew-Wall system includes special detail elements to improve the overall performance of the refurbishment and to meet specific client requirements. The detail elements include: solutions for anchoring the panel to the existing building (RW-X.3 and RW-X.4), solutions for the perimeter surface of the window, solution for the Controlled Mechanical Ventilation machine, etc.

More information on the Renew Wall system can be found in Chapter 3 of D.5.2 of the ARV project.



**Figure 41.** Renew Wall panels: 1\_Renew-Wall Full (RW-F): rectangular solid panel, 2\_Renew-Wall Window (RW-W): panel with window, 3\_ Renew-Wall Door (RW-D) panel with door, 4 Renew-Wall Corner (RW-C): corner panel.  
Source: UNITN.



**Figure 42.** Exploded axonometry of the Renew Wall panel. Source: UNITN.

In order to examine the environmental impacts of the Renew Wall panels, a LCA has been carried out by Habitech. The assessment has been developed complying to the standards EN 15804+A2, ISO 14040:2006, ISO 14044:2006, ISO 14025:2010 and includes the phases A1-A3, A4, C1-C4.

The study shows the evaluation of CO<sub>2</sub>e of biogenic origin and its inclusion in the final result. In addition, the study reports in the conclusions that, comparing the impact values (phases A1-A3) with the impact values found in other literature studies on traditional thermal insulation systems, the Renew-Wall panels have less impact [20].

### **MONITORING PROGRAMME**

The goals of the MONITORING PROGRAMME for the Existing Building are: the thermal energy consumptions, the electrical energy consumptions, the Indoor Environmental Quality and the weather data.

### **Thermal energy consumptions**

The final energy consumptions of the building for heating, Domestic Hot Water (DHW) and cooking will be monitored with a monthly frequency. Aggregated data will be collected because all the mentioned services are provided via natural gas, and it is not possible to install multiple gas or heat meters.

The consumptions will be derived from the energy bills of all the apartments or, if not possible, of a significant number of them. The energy bills will be provided by the condominium manager, both in relation to the historical energy consumption of the building before the renovation and after the ARV intervention. After the consensus of the house owners, the data will be derived from the gas provider using a communication channel (TBD) or directly reading the bills. The occupation profile of the apartments will be evaluated as well and related with the energy consumption of each apartment.

The heating requirement will be determined subtracting the consumption for DHW and cooking from the total. The latter will be calculated starting from simulation outputs or using literature reference parameters.

Since the ARV intervention is only focused on the reduction of the energy consumption for heating, the achieved savings will be determined subtracting the reference consumption of the building before and after the renovation. Reference consumptions will be determined correcting the monthly bill values for the heating degree days (HDD) or heating degree hours (HDH) and by means averaging calculations.

### **Electrical energy consumptions**

The electrical energy consumptions of the building will be monitored for each apartment. Photovoltaic production, self-consumption of the building and energy exportation will be measured as well.

To measure the electrical consumption, we will install energy meters connected to each existing flat energy meter to acquire the main electrical parameters. These meters will communicate data via modbus rtu and they will be connected to a LoRa transceiver to send data to the master using a wireless connection. Sample time will be decided and configured in the master, providing the flexibility to set a sampling frequency that can be lower than 1 minute. Data will be saved locally using a file system and remotely sending data to influx db. Data will be available for further analysis from the influx db.

The photovoltaic production will be measured by the monitoring system that is integrated in the inverter. A bidirectional energy meter will also be installed after the delivery point to measure the energy exchanged with the grid.

### **Indoor Environmental Quality**

The IEQ monitoring will be characterized by the measurement of temperature and relative humidity in a selected number of apartments. The activity will be performed only after the renovation for some weeks, that will be defined in agreement with the owners of the selected apartments.

CO<sub>2</sub> monitoring will not be performed because it goes beyond the scope of the renovation: no intervention on the ventilation system already present in the apartments is expected and the retrofitting will have a negligible influence on the air infiltration flows.

Environmental data will be acquired using small wireless sensors installed in the proper position. These sensors are small (more or less a square with 2 or 9 cm side and 0.5 to 2 cm thick), equipped with long life battery so without maintenance and easy to install without works; they will transmit data every 15 minutes or more to a gateway in a crypted manner. The gateway will be installed in the stairs located in the middle of the building, in a good position to receive data from all the sensors and to transmit data to the master. Data will be sent to influx db by the master, and they will also be saved in the cloud with the possibility to be viewed.

### **Weather data**

Weather data will be provided by the Povo weather station located in the proximity of the ARV renovation site (GPS: 46.07°N 11.16°E, 398m asl.).

### **Envelop performance**

In the existing building, two different solutions will be applied for the façade insulation:

- a. traditional external insulation and finishing system – ETICS (one layer of polyurethane boards plus external plaster as finishing);

b. application of the Renew-Wall system.

In order to evaluate and compare the thermal performance of the two solutions with the same indoor environmental and external weather conditions, a long-life monitoring activity will be performed (12 months in order to consider all the different seasons) on the north façade (minimum influence of solar radiation) corresponding to two selected apartments on the third floor (**Figure 6.10**). Both **surface temperature and thermo-flux sensors** will be applied (**Figure 6.11**) in order to verify:

1. the heat flux trend of the two walls over the 12 months (measurement of winter thermal transmittance and summer thermal inertia);
2. the temperature trend over time (dynamic performance) in each layer of the two solutions.

The analysis will help to define and stress positive and negative aspects of the two solutions and to guide possible future developments and remedies.

More information on the monitoring system of the Existing Building in the ARV TRENTO DEMO site can be found in Chapter 3.6 of D.8.2 of the ARV project.



## 6.2 DESIGN DEVELOPMENT

---

This is the phase where the design intent manifests as a detailed plan. It is important to finalize the details of the ECD before moving into the next phase (DeD) that is preparatory to construction.

The Design Development (DD) of the Existing Building refers to:

- a) the **accurate knowledge** of the context and building conditions (aimed at defining a diagnostic investigation);
- b) the **energy design** (aimed at modelling and energy audits);
- c) the **monitoring design** (aimed at defining the type and location of sensors/equipment).

The final product of the DD is the result of a participatory design process. This chapter briefly describes the *procedures and stakeholders involved, the architectural, environmental, social, economic goals* and the *strategies and solutions* pursued.

### 6.2.1 PROCEDURE AND STAKEHOLDERS INVOLVED

The Design Development (DD) involved the same procedure and stakeholders of the ECD phase. Information, consultation, and collaboration among stakeholders took place through meetings. Participants, dates, locations, and topics discussed are listed in the "Table of Meetings with Stakeholders" (see **Annex 9.3.9\_Table Meetings STAKEHOLDERS\_REFURBISHMENT**).

### 6.2.2 ARCHITECTURAL, ENVIRONMENTAL, SOCIAL, ECONOMIC GOALS (WHAT, WHY, WHO, HOW)

The architectural, environmental, social, economic goals of the DD are the same of the ECD. During the development of the project, a better definition and contextualization was possible.

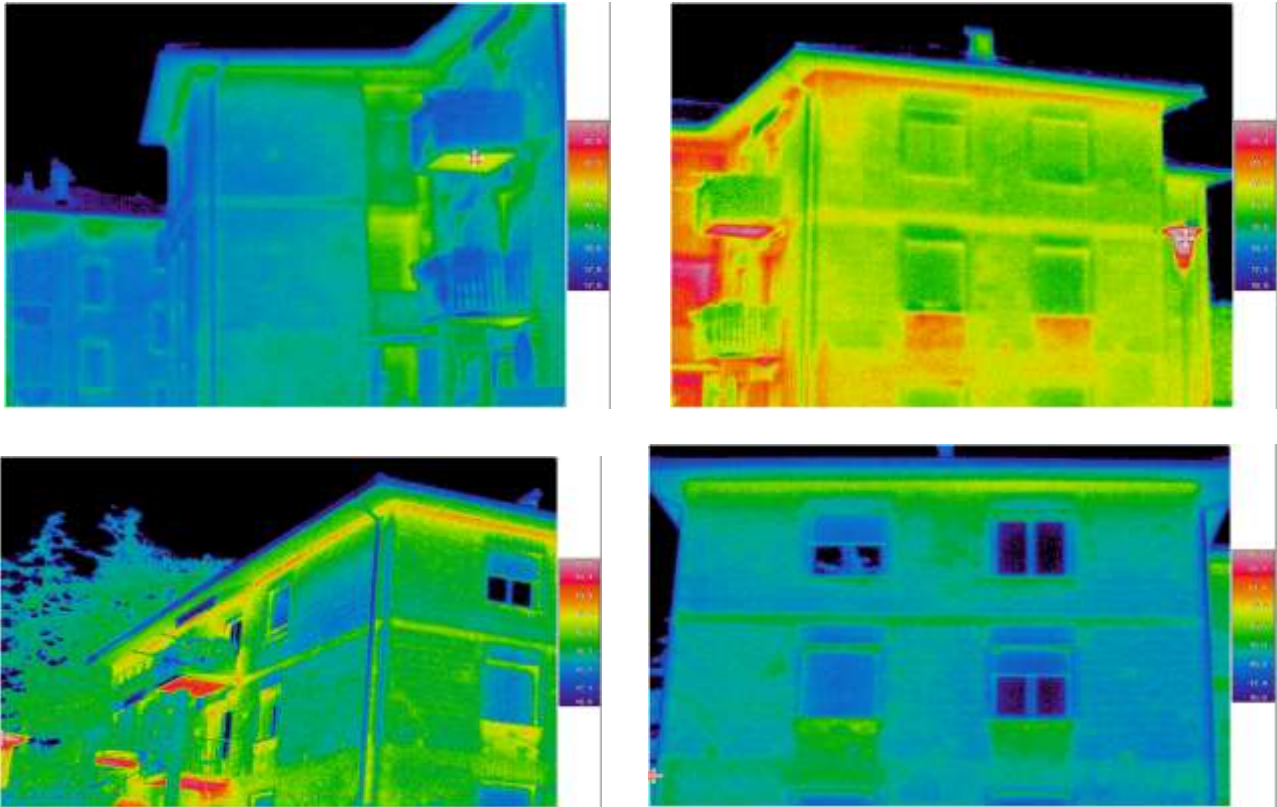
### 6.2.3 STRATEGIES AND SOLUTIONS

Essential for energy retrofitting design is an **accurate KNOWLEDGE** of the context and building conditions regarding its technical-constructive and energy-performance characteristics. The **investigation procedures** adopted to know the existing building were:

- Visual Inspection
- Thermographic Survey
- Geometric Survey.

**Visual Inspection (VI)** is the first step approaching the knowledge of an existing building to retrofit intertwined with geometric and thermograph pattern survey. This action aims at collecting information about the features of the building recognizable to the naked eye. In particular, an initial site visit was carried out with the aim of an initial collecting photographic documentation and visually inspecting the building/plant system. Subsequently, existing documentation (mapping and drawings) concerning the building was collected. Some pictures of the initial VI and some drawings (plans and elevations) of the building are included in the **Annex 9.3.11\_Visual Inspection**.

A **Thermographic Survey (TS)** has been carried out. Infrared Thermography (IF) is one of the most effective and efficient non-destructive testing programmes available. IF surveys help to detect areas of abnormal temperature and diagnose problem areas using a thermal imaging camera which produces a 2-dimensional thermal pictures (**Figure 43**) to identify anomalies such as cold bridging, missing thermal insulation in buildings, etc. The results of the TS are summarised in the **Annex 9.3.12\_Thermographic Survey**.



**Figure 43.** Example of thermographic images of the Existing Building (East façade 1, east façade 2, South-West facade corner and south façade). Source: UNITN.

A **Geometric Survey (GS)** campaign on the case study has been planned and carried out. The goal of this phase was the comparison between different acquisition strategies (**Figures 44**). Following strategies have been tested to assess their effectiveness in outdoor conditions and the rapidity of procedures:

- scanning with LiDAR (Light Detection and Ranging) technology through a mobile device (iPad Pro) from ground level and from an aerial platform (Figure 44.a);
- set of pictures for 3D photogrammetry taken with a 3DEye system (a camera, oriented through a gimbal device, and fixed on a telescopic stick of 9m) (Figure 44.b);
- scanning with SLAM (simultaneous localization and mapping) technology through a mobile device (Zeb Horizon GeoSLAM) from ground level and from the aerial platform (Figure 44.c).

In addition, traditional technologies were applied to compare and therefore assess accuracy of above-mentioned strategies. These are:

- a topographic survey with a total station (4-point polygonal);
- set of pictures for 2D photogrammetry taken from ground level and from the aerial platform.

The results of the GS are summarised in the **Annex 9.3.13 \_ Geometric Survey**.

After the survey phases, the design for the renovation was finalized. All data have been transferred to a BIM software (namely Revit) and a 3D model of the building has been done (**Figure 45**).

The integrated design process with stakeholders defined the installation of the Renew Wall system on two façades (North and East) of the Existing Building of the ARV project (**Figure 46**) in order to have a direct comparison between the new system (innovation of the project) and the traditional insulation system applied on the remaining façades. In particular, are applied two types of panels of the Renew Wall system showed in **Figures 47**: the Renew-Wall Window (RW-W) and the Renew-Wall Corner (RW-C). The exterior-side finish consists of insulation and plaster, while the interior-side finish consists of soft insulation with a thickness of about 6-8 cm, used to absorb the geometric irregularities of the surface to be covered. The anchorage of the panel to the existing building is wood-to-wood, performed by means of vertical uprights pre-fixed to the existing masonry by means of metal plates (**Figure 48**).



**Figure 44.** Scanning with LiDAR technology from the aerial platform (a); acquiring pictures with the 3DEye system (b); scanning with SLAM technology from ground level (c). Source: UNITN.

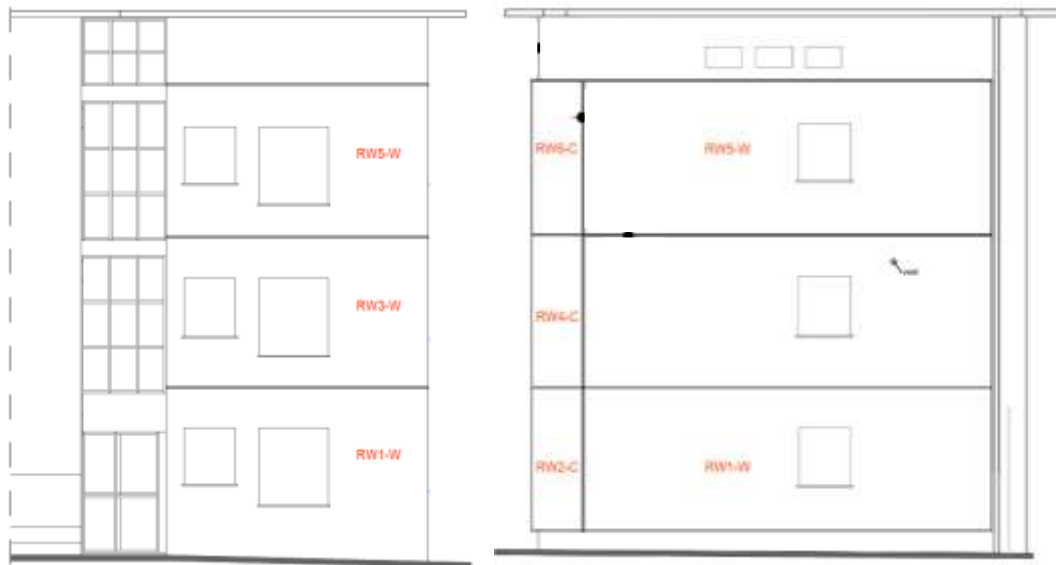


**Figure 45.** 3D model made in BIM (Revit software). Source: ZGAArchitecture.

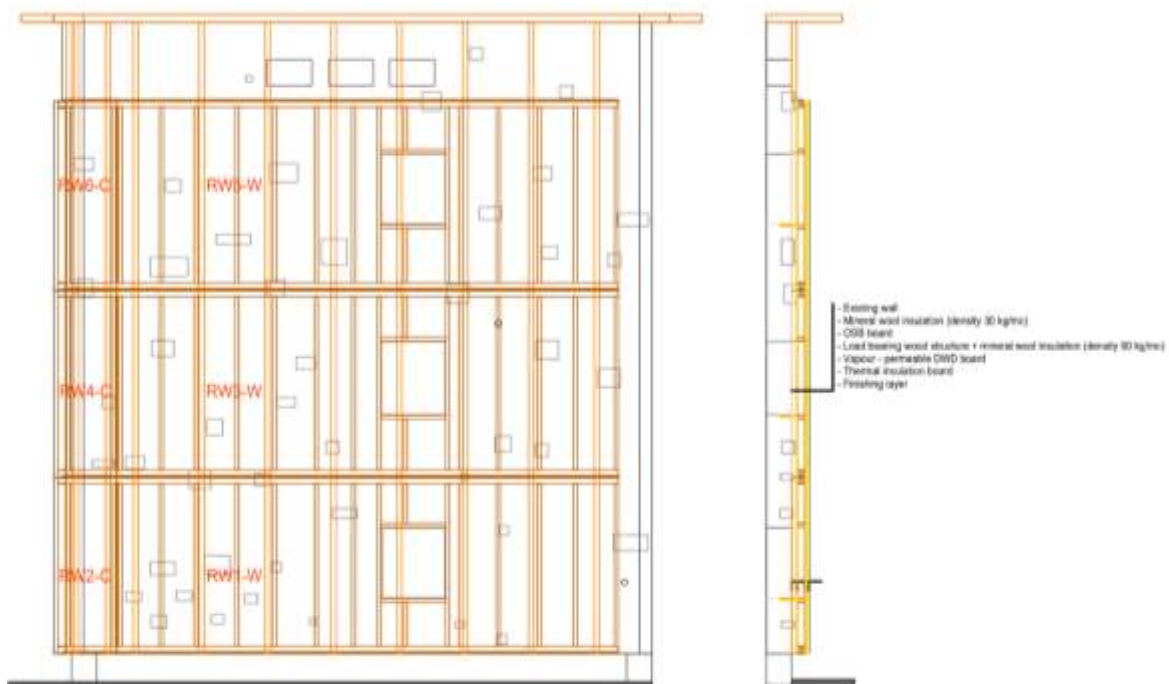


**Figure 46.** North and East façades before the application of the Renew Wall panels. Source: UNITN.

The model has been sent to the Panel producer (Fanti Legnami) whose technician have designed the timber panels following the workflow described in D5.X RESOURCE EFFICIENT CONSTRUCTION WORKFLOWS – DEMO TRENTO (MIDTERM REPORT).



**Figure 47.** Schematic diagram of the Renew Wall panels on the two façades of the building. Source: FANTI LEGNAMI.

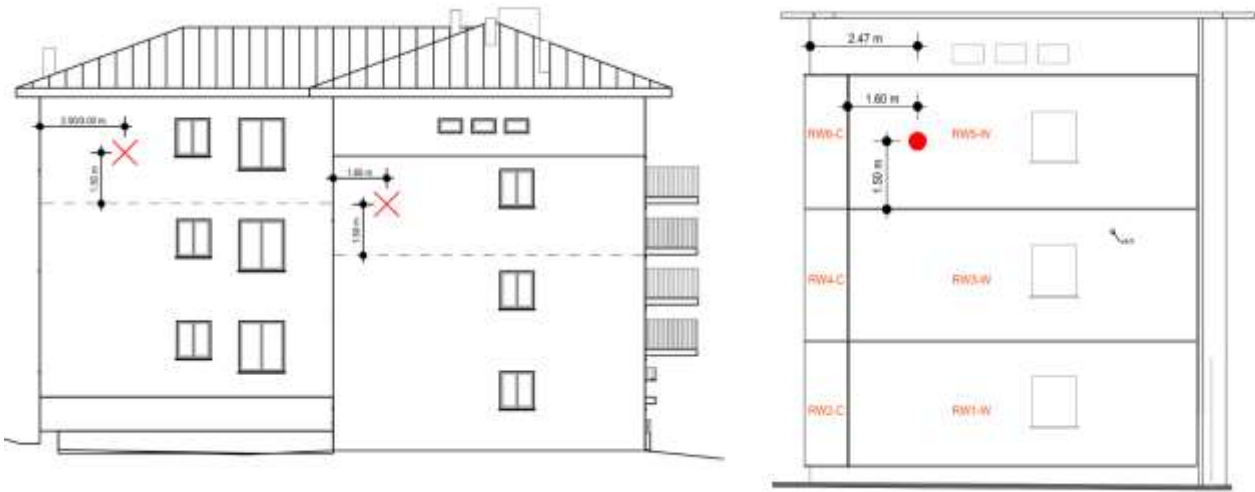


**Figure 48.** Schematic diagram of the Renew Wall system on the two façades of the building. Source: FANTI LEGNAMI.

Designing the installation of sensors to monitor envelope performance in the two proposed thermal insulation solutions was important at this stage of the process. **Figure 49** and **Figure 50** show the schematic diagram of placement of monitoring sensors on façades of the existing building. Some pictures of the installation of surface temperature sensor and heat flow meter in the Renew Wall system and

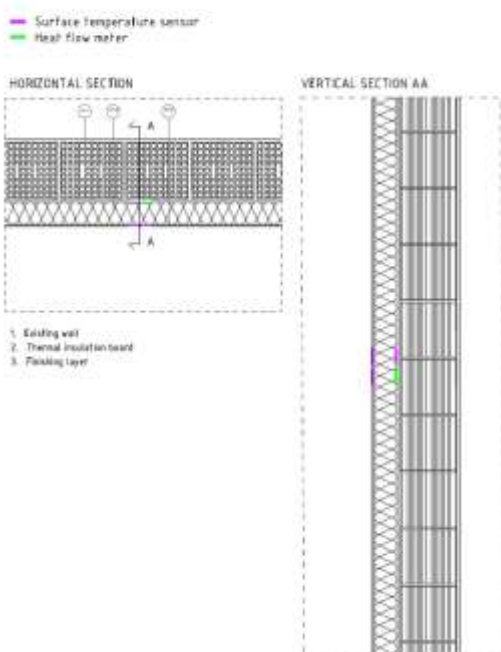


traditional external insulation are in the **Annex 9.3.14\_Installation of Sensors for envelope performance.**

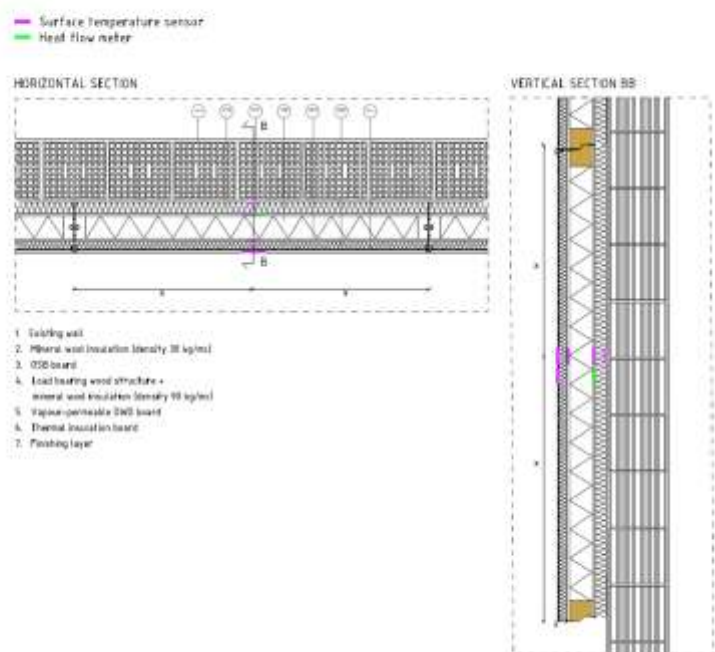


**Figure 49.** Schematic diagram of placement of monitoring sensors on the North-East facades of the existing building Source: UNITN.

EXISTING WALL + ETICS



EXISTING WALL + RENEW-WALL MODULE



**Figure 50.** Surface temperature and thermo-flux sensors to applied of the North-East facades for the monitoring of the Envelope performance. Source: UNITN.

## 6.3 DETAILED DESIGN

---

Detailed Design (DeD) is the phase most commonly used to obtain a contractor for the construction of the building works.

DeD of the Existing Building refers to the selection and sizing of components of the measures defined in DD phase and also provides a level of documentation that clearly defines the design, specification and scheduling of all works and materials necessary to complete the refurbishment design.

The final product of the DeD is the result of a participatory design process. This chapter briefly describes the *procedures and stakeholders involved, the architectural, environmental, social, economic goals* and the *strategies and solutions* pursued.

### 6.3.1 PROCEDURE AND STAKEHOLDERS INVOLVED

The DeD involved the same procedure and stakeholders of the ECD and DD phase. Information, consultation, and collaboration among stakeholders took place through meetings. Participants, dates, locations, and topics discussed are listed in the "Table of Meetings with Stakeholders" (see **Annex 9.3.9\_ Table Meetings STAKEHOLDERS\_REFURBISHMENT**).

### 6.3.2 ARCHITECTURAL, ENVIRONMENTAL, SOCIAL, ECONOMIC GOALS (WHAT, WHY, WHO, HOW)

### 6.3.3 STRATEGIES AND SOLUTIONS

To improve the energy performance, intervention strategies with technical solutions were applied to external envelope and systems of the building. The following solutions were detailed designed:

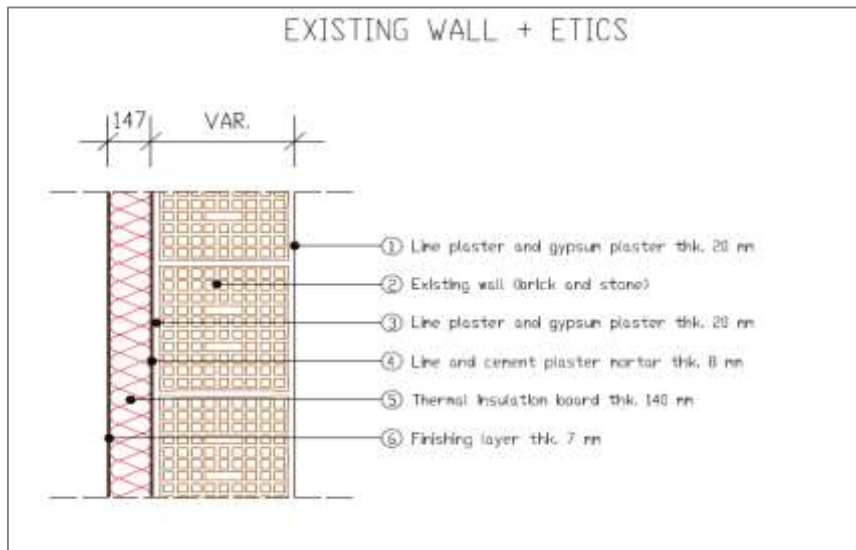
- thermal insulation of the opaque and transparent walls and attic floor and thermal bridges elimination ("towing" intervention on common parts);
- replacement of windows ("towed" intervention on common and private parts);
- replacement of doors ("towed" intervention on private parts);
- installation of photovoltaic panels with storage on the roof ("towed" intervention on common parts);
- replacement of heating plants ("towed" intervention on private parts).

In addition, to improve the architectural quality of the building, has been defined the solutions that can change the building appearance of the building such as the transformation of the balconies with new railings, the color of the windows and its roller shutters and the color of the walls.

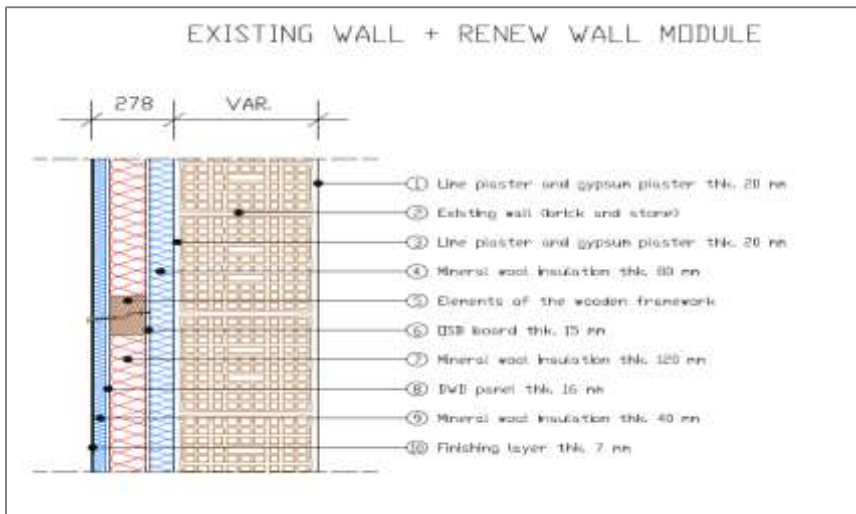
**Figure 51** shows the detailed design of the external thermal insulation of the envelope with the standard solution (ETICS). It applies on the existing walls 14 cm of EPS insulation and 7-mm of finishing layer. The total thickness of the ETICS solution is 147 mm.

**Figure 52** shows the detailed design of the external thermal insulation of the envelope with the industrialized solution of the Renew Wall system with a total thickness of 278 mm. In this prefabricated system there are 3 layers of mineral wool insulation panels with different thicknesses (80mm,120mm and 40mm) that help ensure high performance. The total thickness of this solution is 278 mm.

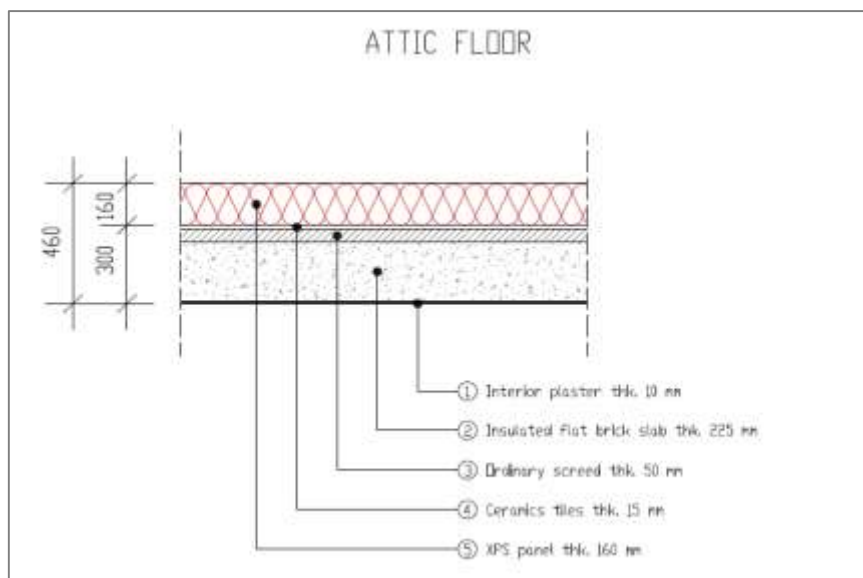
**Figure 53** shows the stratigraphy to thermally insulate the slab between the attic and the top floor inhabited. The stratigraphy includes 160 mm of XPS insulation.



**Figure 51.** Wall stratigraphy with EPS insulation (ETICS). Source: LEVA srl.



**Figure 52.** Wall stratigraphy with Renew Wall system. Source: LEVA srl.

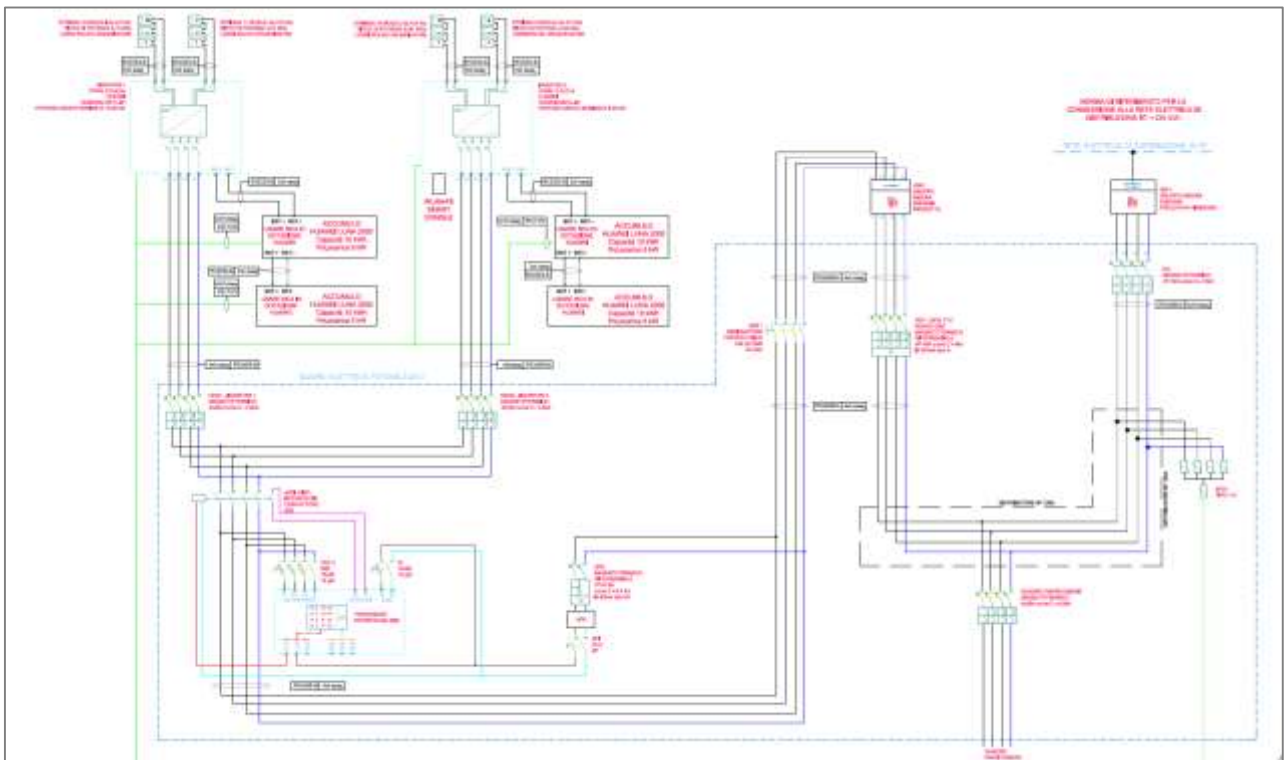


**Figure 53.** Slab stratigraphy with XPS insulation. Source: LEVA srl.

In this phase of the design process, after the survey activities, the feasibility of the insulation of the cellar floor was verified. Unfortunately, it is not possible to isolate the slab between the cellars and inhabited floor due to problems related to height and regulatory constraints.

Windows replacement is characterized by high-performance windows with PVC frame, triple glazing and low-emissivity coatings, solar factor 0.50 and insulated box. All apartments except one replace the windows; only 5 of the 9 apartments replace the entrance door selected with thermal characteristics for climate zone E (according Italian legislation) and Superbonus 110%.

The PV system (**Figure 54**) consists of 48 high-efficiency modules to be installed with point anchors on the pitches of the tiled roof, and more specifically on the south (~37 m<sup>2</sup>) and west (~44 m<sup>2</sup>) pitches with a 17° slope. The peak power of the PV system is 19,68 kWp with 40 kWh. The PV system is connected to a storage system consisting of state-of-the-art batteries.



**Figure 54.** Photovoltaic system diagram. Source: LEVA srl.

With regard to the replacement of the existing heating plants of the 9 housing units, the design proposed a hybrid technology combining condensing gas and air to water heat pump for heating and hot water, or alternatively boilers of last generation.

The expected energy performances have been calculated by LEVA s.r.l. on the basis of the solutions developed in the DeD phase. An energy analysis has been carried out to verify the requirements of the Superbonus 110%; it is the energy report for the winter/summer required by Legislative Decree 192/2005, as amended, commonly known as "ex Legge 10". Considering the energy classes of the Italian context, the analysis highlighted the jump of two energy classes of all the housing units.

**Table 7** refers the results of the energy analysis in terms of global energy performance index value "EP" (primary energy) with the related Energy class for the 9 housing units of the building. In particular, two housing units (PM1 and PM5) reach the energy "A+" class replacing the heating plant with a hybrid system.



**Table 7.** Values of primary energy (EP) and energy classes calculated for the housing units of the existing building. Source: LEVA srl.

Unit	EP [kWh/m2]	Design energy class
1 (PM1)	16.03	A+
2 (PM3)	99.30	C
3 (PM2)	105.03	C
4 (PM4)	96.27	C
5 (PM6)	62.78	C+
6 (PM5)	8.25	A+
7 (PM7)	70.58	C+
8 (PM9)	76.00	C+
9 (PM8)	87.82	C

The works for the Existing Building renovation carried out in the period from August to December 2023. Pictures of the onsite works of the building renovation are in the **Annex 9.3.15\_Construction site\_REFURBISHMENT**, that includes the installation of EPS insulation (see also **Figure 55**), the installation of the Renew Wall panels (see also **Figure 56**), the replacement of windows and doors, the installation of PV panels on the roof, and the replacement of heating plants.



**Figure 55.** Installation of the EPS insulation. Source: LEVA Srl.



*Figure 56. Installation of the Renew Wall panels. Source: UNITN.*

## 6.4 BENCHMARK THE SOLUTION AGAINST ARV KPIS

CPCCs in ARV should strive towards 50% reduction in life cycle embodied GHG emissions compared to ex-ante condition or current practice. To be able to make such comparison, two steps were performed:

- first, the total primary energy of the refurbished state is computed and compared with a benchmark scenario;
- then, the life-cycle embodied GHG emissions (and Cumulative Energy Demand) were estimated through an LCA study.

### 6.4.1 TOTAL PRIMARY ENERGY

In order to compute the total energy primary demand of the building in its refurbished state, an energy simulation has been carried out by using the software TERMUS, which is a semi-stationary energy calculation software validated according to the Italian Standard UNI/TS 11300 “Energy performance of buildings”. It should be stressed that the energy simulations allowed us to have just a theoretical prediction of the actual consumption. Then, the actual primary energy demand could differ from the numerical one, mainly depending on the actual use of the building and on actual weather conditions.

In **Table 8**, the simulated, annual non-renewable primary energy demand ( $EP_{gl,nren}$ ) of the renovated building is reported, computed as the average of the results obtained for the different dwelling weighted on the different areas. In order to check if the planned renovation leads to a reduction in the energy need compared to the pre-renovation level, a reference primary energy has been considered. This value is representative of the average non-renewable primary energy observed in Italian residential buildings built in the same period and same climatic zone of the renovated building. The representative total primary energy and the calculated difference (in kWh/m<sup>2</sup> & percent) can be found in **Table 8**. As we can see from the results, the renovated part of the building achieves the target of 68% reduction in primary energy compared to pre-renovation levels.

**Table 8.** Simulated annual non-renewable primary energy demand  $EP_{gl,nren}$  of the renovated building and of the representative building.

Simulated $EP_{gl,nren}$ [kWh/m <sup>2</sup> ]	Representative $EP_{gl,nren}$ [kWh/m <sup>2</sup> ]	Difference [kWh/m <sup>2</sup> ]	Difference [%]
69.27	219.9	150.63	- 68 %

### 6.4.2 LIFE CYCLE ASSESSMENT AND LIFE CYCLE COST

The LCA calculation is a quantitative assessment of emissions of GHGs, and Cumulative Energy Demand (CED) associated with materials over a lifetime of 50 years, and describes the project's impact on climate change, measured in kgCO<sub>2</sub>-eq and kWh/y, respectively. The results are standardized based on the total heated area of the selected building. The lifecycle modules are organized according to the European standard EN 15978:2011. **Table 9** summarizes the life cycle modules included in the study. In particular, the system boundaries encompass the construction phase (modules A1-A4), component replacements (module B4), operational energy use (module B6), and end-of-life stages (modules C1-C4).

**Table 9.** Life cycle modules considered in this work.

LCA module	Description	Included
A1	Raw material extraction and processing	✓
A2	Transport to the manufacturer	✓
A3	Manufacturing process	✓
A4	Transport to the building site	✓
A5	Installation in the building site	x
B1	Use	x
B2	Maintenance	x

B3	Repair	x
B4	Replacement	✓
B5	Refurbishment	x
B6	Operational energy use	✓
B7	Operational water use	x
C1	Demolition, de-construction	✓
C2	Transport to waste treatment facilities	✓
C3	Waste processing	✓
C4	Disposal	✓
D	Reuse, recovery or recycle potential	x
	Renewable energy production	✓
	Biogenic carbon	✓

Considering the module A4, if transportation wasn't originally integrated into the process used in the modelling, we assumed a transportation distance of 60 km to the construction site.

In order to model the module B4 the following service lives were considered: 35 years for windows and insulation materials, 25 years for wall linings, 10 years for wall coverings, 20 years for services, 25 years for PV power plants and 10 years for batteries.

Module B6 accounts for the impacts linked to the operational energy use for heating and DHW. The data are derived from preliminary energy simulations performed using a semi-stationary energy modelling tool. The scope of these simulations was to realize an energy audit of the building, to fill in the energy certificate or to compile the report required by the Italian legislation for energy renovations (law n.10 of 1991).

The substitution principle is applied to evaluate the benefits achievable in the module D. The research employs a cut-off strategy. In particular, the potential advantages of recycling materials were not fully simulated through their entire recycling lifecycle. The individual benefits of recycling and reusing materials, along with those from exporting renewable energy and biogenic carbon, have been recorded in module D.

Lastly, the materials from pre-existing buildings are considered to have no environmental impacts. Moreover, the model excludes maintenance or end-of-life waste for these materials, focusing instead on waste produced during renovation activities.

Ecoinvent V3.9 was used as the main background database for LCA modelling while local price lists were adopted for cost calculations. Results are aggregated in terms of embodied impacts (modules A1-A4), embodied recurring impacts (module B4), operational impacts (module B6), end-of-life impacts (modules C1-C4) and benefits achievable (module D).

**Figure 57** and **59** illustrate the primary energy needs (kWh/m<sup>2</sup>y) and CO<sub>2</sub> equivalent emissions (kg CO<sub>2</sub>-eq/m<sup>2</sup>y) across various stages of the renovation life cycle, with their proportional contributions to the total showcased in **Figure 58** and **60**. Analysing the Cumulative Energy Demand (CED), it became evident that a significant portion, approximately 84%, of the primary energy usage was due to building operation energy (module B6). The initial construction phases (modules A1-A4) only accounted for 7% of the total. Meanwhile, the energy needs related to end-of-life processes and transportation to the construction site (module A4) were minimal, less than 1% as depicted in Figure 13. Conversely, the impact of module B4 (building component replacements) was notable at 9%, influenced by the fact that each renovation component was either replaced or upgraded. Finally, the CED data reveals that electricity generated by photovoltaic systems can offset about 144% of the non-renewable CED of the renovation life cycle.

When examining the Global Warming Potential (GWP), operational stage emissions constituted 78% of the total, with embodied carbon (initial and recurring) making up 20%. The top three contributors to embodied carbon were the installation of photovoltaic systems and insulation of external walls and attics. This finding relates to the extent of surface area involved and the quantity of materials used.



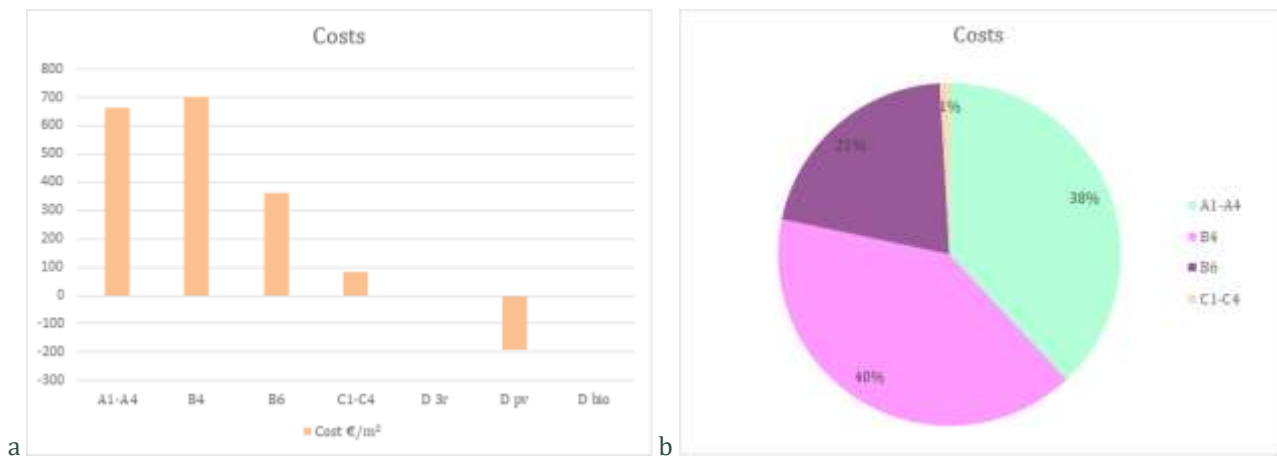
Additionally, the use of carbon-intensive EPS insulation in traditional coats was notable. The recurring embodied carbon significantly influences the overall life cycle GWP, exceeding the impact of initial renovations due to the replacement of components.



a) **Figure 57.** Life cycle cumulative energy demand for the renovation in Povo; b) **Figure 58.** Share of the different life cycle stages in the total CED of the renovation in Povo; c) **Figure 59.** Life cycle global warming potential for the renovation in Povo; d) **Figure 60.** Share of the different life cycle stages in the total GWP of the renovation in Povo (module D is excluded). Source: EURAC.

Concerning the life cycle cost assessment, this showed a different trend, with initial investment and future replacement costs (modules A1-A5) constituting 78% of life cycle costs, as shown in **Figures 61 and 62**. Operational energy consumption (module B6) was the third highest cost factor, accounting for 21%. End-of-life stages contributed 1% to the total renovation cost. Insulating the building envelope was a major cost factor, both in material quantity and labour hours. It should be noted that this result is affected by the recent rise in construction material prices in Italy, as highlighted by authors like Casarin [21] and De Masi et al. [22], caused by the "Superbonus 110%" incentive schemes under the "Relaunch" Law Decree No. 34/2020.

A comparison can be made between the pre-retrofit (ex-ante) and the post-retrofit (low-e) scenario. **Figure 63** showcases the Life Cycle Assessment (LCA) outcomes for the evaluated scenarios. The renovation notably reduced the building's environmental impact by approximately 74%-77%, considering the non-renewable Cumulative Energy Demand (CED) and the Global Warming Potential (GWP). This improvement was achieved without factoring in the additional environmental benefits arising from the exportation of renewable energy.

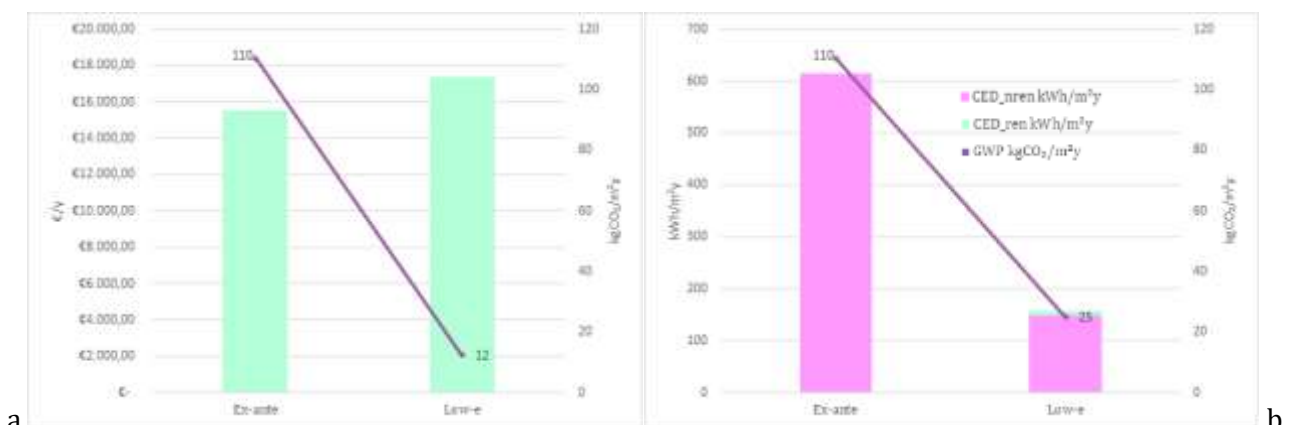


a) **Figure 61.** Life cycle costs for the renovation in Povo; b) **Figure 62.** Share of the different life cycle stages in the total LCC of the renovation in Povo (module D is excluded). Source: EURAC.

However, the life cycle cost analysis, depicted in **Figure 64**, indicates a marginal increase in costs due to the renovation. This increase primarily stems from high initial investment and replacement costs. It should be noted that the uncertainty in these results is significant, influenced by various factors that could either negatively or positively impact the economic viability of the project:

- Static energy prices in the model, susceptible to real-world fluctuations in energy costs.
- Potential unanticipated hikes in construction or renovation expenses due to temporary market dynamics.
- Variations in actual energy usage compared to initial estimates, influenced by changes in occupancy, equipment usage, or user behaviour.
- Degradation in the efficiency of insulation materials or photovoltaic panels over time.

Specifically, an increase in energy prices, which seems probable under current energy policies, could enhance the economic attractiveness of the renovation project. Adverse conditions combined with moderate increases in energy costs may lower the anticipated return on investment for energy renovation initiatives. The current surge in construction material prices has also adversely affected the investment cost of the project. In the context of energy retrofits, other factors such as high discount rates, especially when renovations are financed through loans, can significantly influence life cycle cost performance. These aspects were not included in the simplified Life Cycle Cost (LCC) method used in this study, which does not consider discounting of future cash flows and revenues. Nonetheless, the availability of incentives for energy renovation projects remains a crucial factor in facilitating such interventions in Povo. More information on the application LCA-LCC concerning the Trento Demo can be found in the section 4.3 of D.8.5 of the ARV project.



a) **Figure 63.** CED (lefts axis) and GWP (right axis) for the different renovation scenarios considered. (module D excluded); b) **Figure 64.** LCC (lefts axis) and GWP (right axis) for the different renovation scenarios considered. (module D included). Source: EURAC.

### 6.4.3 INDOOR ENVIRONMENTAL QUALITY

Actions to be implemented in the next year

#### 6.4.3 NOISE DURING RETROFITTING

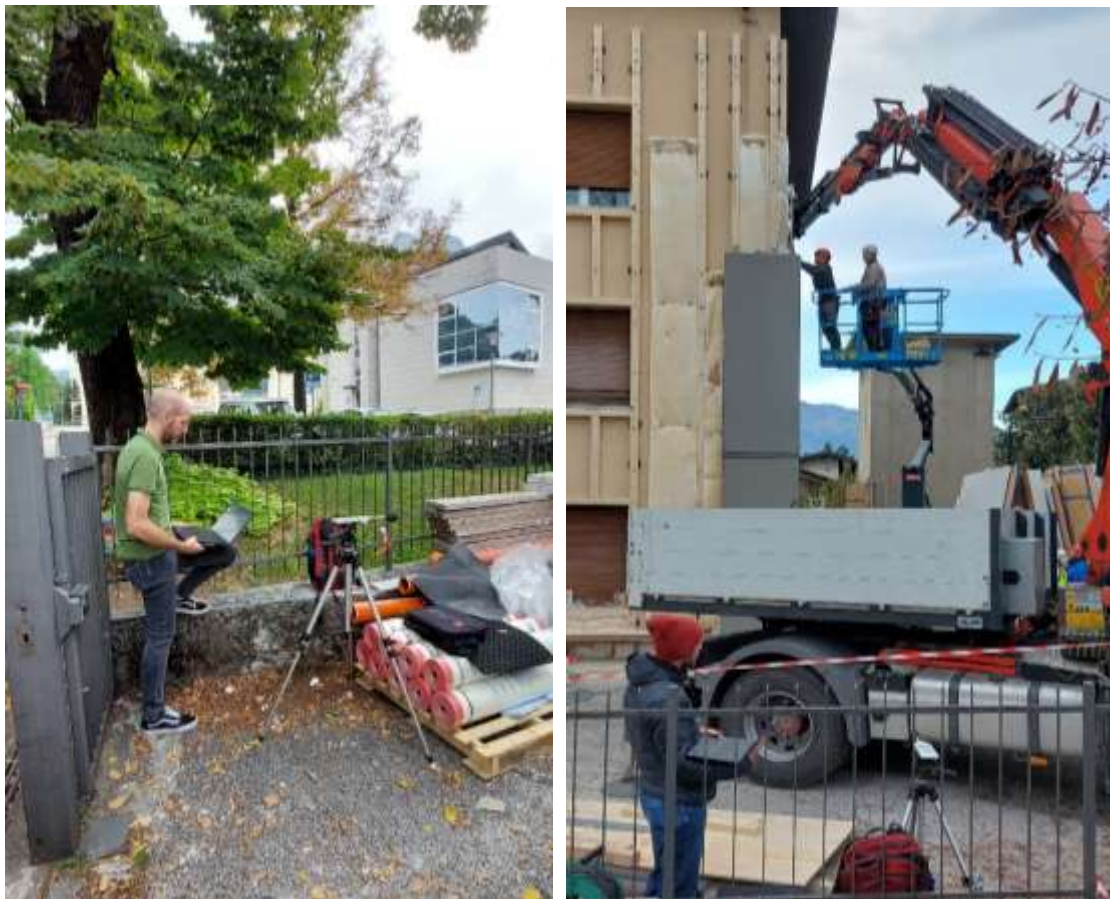
In recent years, sensitivity to noise-induced disturbance has increased significantly. The noise emissions generated by the activities carried out on construction sites are one of the causes of greatest disturbance within indoor living environments.

People living or working in buildings near a construction site have a legitimate need for acoustic comfort, and this implies that noise generators must implement all the necessary strategies to ensure that noise is not only as low as possible, but also as easily tolerated.

The noise impact of a construction site must therefore be studied to assess it, and identify tools and procedures to minimise discomfort and make it acceptable for citizens.

To this end, during the installation of the traditional insulation (ETICS) and of the Renew Wall system concerning the Existing Building, UNITN carried out acoustic tests using a sound level meter (Figure 65), and interviewed the occupants using a questionnaire administered the day after the works.

The results of the surveys are currently being processed.



**Figure 65.** Noise monitoring for construction site of the Existing Buildings using a sound level meter mounted on a tripod at a boundary position and left to measure noise over a specific period of time.

Source: UNITN.

## **6.5 SUMMARY**

---

### **6.5.1 ARCHITECTURAL QUALITIES**

### **6.5.2 SOCIAL QUALITIES**

### **6.5.3 ENVIRONMENTAL SUSTAINABILITY**

### **6.5.4 ECONOMIC FRAMEWORK**

Parts to be implemented in the next year

## **6.6 DESIGN REPLICABILITY AND TRANSFERABILITY IN THE URBAN AREA**

---

### **6.6.1 OPPORTUNITIES**

### **6.6.2 CHALLENGES**

### **6.6.3 STRATEGIES AND SOLUTIONS**

Parts to be implemented in the next year



## 7. INNOVATIONS IN THE DESTRA ADIGE - PIEDICASTELLO DEMO

---

The innovations developed for the project in the Destra Adige Piedicastello are presented in this chapter.

### *INNOVATION #1:*

*A catalogue of Integrated Circular Design solutions for building refurbishment with 50% of energy reduction and positive energy new construction, mainly acting on: building envelopes with active (BAPV/BIPV) and passive elements, nature-based solutions integration, inform Industry 4.0 via digital surveys, comfort improvement (psychological, physiological).*

It has been implemented in the ECD phase of the New Building. Particularly, the main factors it pertains to are Energy, Architectural quality, and Environmental sustainability.

The innovation is a catalogue of integrated circular and sustainable solutions for positive and low carbon footprint buildings which aims to be of help and support to all possible stakeholders (from designers to users), and especially to drive public administration and decision-makers to the proper choice of sustainable solutions for new buildings and refurbishment of existing ones, considering circular design practices integrated into Buildings 4.0 vision. Both physical solutions and digital ones have been considered, categorized as: Urban Green Infrastructure, Blue Infrastructure, Energy Systems, Shading devices, Building technologies, and Digital solutions. Each category is further divided in sub-categories, according to the type of solution considered. Each category answers to a specific climate-related challenge: Energy sustainability, Temperature regulation, Sustainable water management, Health and wellbeing, and synergies among them are highlighted as well.

For each solution, the catalogue provides a brief description, the challenges it responds to, the objectives it can achieve, the performances it can guarantee and the benefits, even if not strictly related to the challenges. Each solution refers to one or more case studies defined as best practices.

The performances of each solution constitute the due process to achieve the specific objective given in a design and planning procedure, driven by enabling processes of the built environment. As such, performances can be measured and controlled by practitioners. Designing through a climate sensitive approach relies on the understanding of the relationship between the built environment and urban climate and on the management of parameters and interactions among them. One of the main innovative aspects of the catalogue is the presence of information sheets on products, building systems and technologies, mainly related to companies in the local production fabric, which can contribute to the implementation of the proposed solutions.

The catalogue presents a range of possible physical and digital solutions that can be applied especially in a SUSTAINABLE BUILDING (RE)DESIGN process, in particular (but not only) in the ECD phase of new and existing buildings. Solutions are presented in general terms and real market products (particularly at a local/regional level) are listed. Depending on local environmental conditions and intended use of the building, pros and cons of each solution concerning environmental challenges are defined, with specific objectives and related performances. Especially designers and public administration technicians can refer to the catalogue so to guide their choice towards a local, circular and efficient (re)design and planning process.

In order to finalize this action, Habitech, in collaboration with the University of Trento, the Polytechnic of Turin and EURAC, has launched a consultation through a questionnaire available at the following link <https://forms.office.com/r/vTLuiHr93T>.

The consultation aims at identifying products, building systems and technologies, mainly related to local companies that can contribute to the implementation of the proposed solutions and that will be included in detailed information sheets within the Catalogue.

In order to promote the involvement of companies, a flyer was prepared (**Figure 66**) that briefly presents the catalogue and lists the possible advantages and opportunities for companies wishing to apply:

- local, national, and international visibility of your product/technology/system
- link to a European Green Deal project;
- promotion, information and training for the construction sector, public and private clients, end users;
- opportunity for synergies between building stakeholders and the world of research;
- active contribution to the challenge of the circular economy and integration into Building 4.0 processes.

The collected data will be analysed for research purposes by the ARV project team and may be made public to enrich the Catalogue information sheets.

**Candida il tuo prodotto nel Catalogo di soluzioni circolari e sostenibili del progetto europeo ARV!**

**Cos'è ARV?**  
 Il progetto europeo ARV (parola norvegese che significa "eredità", ma anche "patrimonio costruito") intende esplorare la possibilità di generare **Comunità Circolari Climatiche e Positive** che si basano sull'interazione e l'integrazione tra gli edifici, gli utenti e i sistemi locali di **energia, mobilità e ICT**, includendo anche gli aspetti socio-ambientali e ponendo in evidenza come elemento fondamentale la circolarità dei processi. Finanziato nell'ambito di **Horizon 2020**, che supporta il Green Deal Europeo, ARV coinvolge sei Paesi: **Norvegia** (coordinatore), **Italia, Spagna, Olanda, Danimarca, Repubblica Ceca**.

**Il sito dimostrativo di Trento - Piedadcastello**  
 Le tematiche del progetto sono approfondite attraverso sei progetti dimostrativi localizzati nei Paesi partecipanti. Il demo italiano è collocato a Trento nella zona di **Piedadcastello - Destra Adige** ed è coordinato da **Eurac Research e Habitech**, con la collaborazione di **Università di Trento, Dolomiti Energia e Politecnico di Torino** e con il supporto esterno di **Provincia autonoma di Trento e Comune di Trento**. Il progetto riguarda la costruzione di un nuovo edificio e il recupero di uno esistente tramite l'utilizzo di soluzioni positive, circolari e nature-based per edifici 4.0, fuoio di pannelli prefabbricati a base legno e impianti da fonti rinnovabili con sistemi innovativi di sonde geotermiche.

**Il Catalogo**  
 Una delle key-innovation del progetto è la realizzazione di un **Catalogo di soluzioni integrate circolari e sostenibili** da adottare per la realizzazione di edifici positivi e a bassa impronta ecologica. Il catalogo fornisce, per ogni soluzione, una breve descrizione, le sfide a cui risponde, gli obiettivi che può raggiungere, le prestazioni che può garantire e i benefici anche non strettamente correlati alle sfide. Ogni soluzione è riferita a uno o più casi studio definiti come *best practice*.

Uno degli aspetti innovativi del catalogo è la presenza di **schede informative riguardanti prodotti, sistemi costruttivi e tecnologie**, principalmente relativi a imprese/aziende del tessuto produttivo locale, che possono contribuire all'attuazione delle soluzioni proposte.

**Quali vantaggi e opportunità per le imprese che intendono partecipare?**

- **Visibilità** locale, nazionale e internazionale del proprio prodotto/tecnologia/sistema
- **Collegamento a progetto europeo** in ambito Green Deal
- **Promozione e (in)formazione** per filiera dell'edilizia, committenza pubblica e privata, utilizzatori finali
- **Opportunità di sinergia** tra stakeholder dell'edilizia e mondo della ricerca
- **Contributo attivo alla sfida** dell'economia circolare e integrazione nei processi dell'edilizia 4.0.

Vuoi essere parte di questo progetto innovativo? **Invia la tua candidatura** compilando il seguente form online: <https://forms.office.com/r/vTLuHr93T>

Il team del progetto ARV ti terrà aggiornato sulla possibilità di inserire la tua tecnologia all'interno del Catalogo.

**ARV** This project has received funding from the European Union's Horizon 2020 research and innovation programme under grant agreement No. 101019123

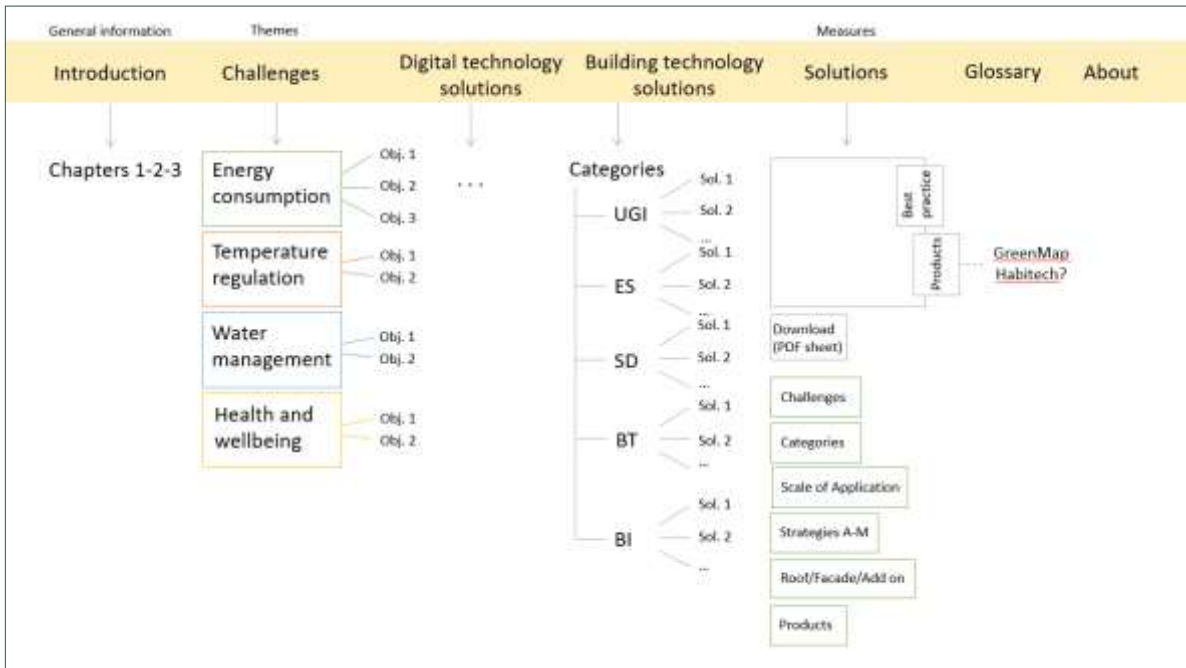
**Figure 66.** Flyer for the involvement of companies contributing to the implementation of catalogue solutions. Source: Habitech

In May 2023, a second version of the catalogue has been issued, where some more solutions for the building envelope have been added.

After the call/flyer for the involvement of companies have been sent to Habitech consortium members, up to Nov 2023, 12 products have been listed in the Catalogue.

In order to allow an easier updating of the Catalogue, the idea is to transform the current static version (basically a pdf file) in a dynamic one, based on a web site format. The general scheme of the website has been developed (**Figure 67**). After a general Introduction of the ARV project and of the catalogue itself, a session with the description of the main challenges and their objective is presented, followed by the Digital technology solutions and the Building technology solutions, ordered following the different categories.

A search by solutions is possible as well, where both Best practices and Products (also linked to existing database, as GreenMap of Habitech) are presented. Finally, a Glossary and a session About are provided.



**Figure 67.** General scheme for the development of the dynamic version of the Catalogue. Source: UNITN

The dynamic catalogue can be implemented continuously either by the master or by the companies themselves that can enter the website by their own with a specific username and password. The catalogue will be of free access and open to the public, so to present always new and updated solutions available on the market.

**INNOVATION #2:**

*Natural and mechanical ventilation concepts for climate responsive buildings.*

It has been implemented in the ECD phase of the New Building. Particularly, the main factors it pertains to are Energy and Architectural quality.

The purpose of the study on Natural and Mechanical Ventilation concepts for climate responsive buildings is to offer an overview on IEQ conditions created by different ventilation types, defining pros and cons of natural ventilation techniques in buildings vs mechanical ones. A framework on scientific evidence of papers comparing NV and MV in terms of comfort and well-being has been provided, in a perspective of performant and sustainable buildings' design (e.g., nZEBs, nPEBs, climate responsive).

The main hypothesis is that ventilation is firstly aimed to provide IEQ, with energy savings as a very important additional aim. For this reason, the following research questions were explored:

1. Which differences are present between IEQ conditions guaranteed by NV and MV?
2. Which ventilation techniques are more suitable at different climates, seasonal and outdoor pollution conditions, according to both IEQ and energy perspectives?
3. Which ventilation techniques are more suitable with different building types and uses?
4. Which are the research gaps in terms of effects of NV and MV on the IEQ, depending on the type of building, the ventilation technique and the comfort domain considered?

The outcomes of the study can be useful for understanding the main research gaps in the field and to guide designers in the best choice to ensure comfort and well-being in nZEB and nPEB design, also with attention to proper ventilation of indoor spaces.

The outcomes of the study can be exploited by policymakers, in order to further expand and update ventilation standards and guidelines considering both energy consumption and indoor well-being. The development of such guidelines is fundamental for engineers, architects and planners, in order to help them in conscious and contemplated choices during the design process. In particular, the study can be applied during the ECD phase of the building (re)design in order to properly define the building shape and devices for ventilation and night cooling techniques towards energy saving and human well-being.

The results of the study were published in the paper entitled “Natural and Mechanical Ventilation Concepts for Indoor Comfort and Well-Being with a Sustainable Design Perspective:

A Systematic Review” in the issue n.12 of the scientific, peer-reviewed, open access journal Buildings (see **Annex 9.3.5**).

### **INNOVATION #3:**

*Architectural and aesthetic integration of BIPV/BAPV/PVT solutions; materials selection; integration between PV, Solar Thermal and CMV systems.*

It has been implemented in the design phase of the New Building. Particularly, the main factors it pertains to are Energy and Architectural quality.

The strategic role of the energy sector in European decarbonisation is fundamental for achieving climate neutrality by 2050. The shift to energy communities has also been supported by new regulatory standards which in some cases also have implications for architecture. One example is the standard Photovoltaics in Buildings EN 50583:2016 which was the first to include the integrated photovoltaic module in a multi-functional construction component, in accordance with the Construction Products Regulation (EU) CPR 305/2011. This new interpretation has assisted with the move from PV to smart BIPV systems as innovative technological components contributing to tackling current decarbonisation challenges [2, 3]. These processes have stimulated the market through R&D to produce new generation smart materials which can generate electricity, extending the surface area of the building envelope used for this purpose. This approach has led to a change of interpretation in how building systems are incorporated into the architectural design, as shown in the case studies analysed in this paper.

The research group at the Politecnico di Torino Department of Architecture and Design (POLITO-DAD) analysed reports and scientific articles published by European research institutions in detail, and major online databases for sharing BIPV best practices were consulted. Interviews were also conducted, as a means for comparison and critical analysis, with BIPV innovation technology researchers from a number of European organisations, such as the NEST<sup>11</sup> research lab in Zurich, SUPSI<sup>12</sup> and EPFL<sup>13</sup>. A comparison of the leading European producers of BIPV modules, such as SwissINSO, AGC Glass and Ertex Solar, has been made to complete the analytical framework. A summary of the sources consulted is presented in **Figure 68**.

As a result of the analysis, 78 BIPV integrated façades in Europe were identified and analysed, of which 67% related to the residential construction sector. First generation (c-Si), second generation (a-Si, CIGS, CIS, CdTe) and third generation (OPV, DSSC) PVs were all considered. It is relevant to show how – as a result of the technological innovation in PV aesthetics, which started in 2010 – 39.4% of the surveyed façades had adopted completely camouflaged solutions or coloured PV cells (**Figure 69**). These first results of the research project were presented within the framework of the international conference

---

<sup>11</sup> Modular research and innovation building NEST (Next Evolution in Sustainable Building Technologies) of Empa and Eawag, Zurich, Switzerland.

<sup>12</sup> University of Applied Sciences and Arts of Southern, Lugano, Switzerland.

<sup>13</sup> Swiss Federal Institute of Technology, Lausanne, Switzerland.



"CONF.ITECH 2022. Technological imagination in the green and digital transition" (Roma, 30/6 1-2/7, 2022). The scientific paper by Guido Callegari, Paolo Simeone, and Eleonora Merolla entitled "Photovoltaic breakthrough in architecture: integration and innovation best practice" is included in the Proceedings to published by Springer International Publishing AG in the next few months.

scientific papers	selected content
1 D'Ambrosio V., Losasso M., Tersigni E (2021) Towards the Energy Transition of the Building Stock with BIPV: Innovations, Gaps and Potential Steps for a Widespread Use of Multifunctional PV Components in the Building Envelope	Product customisation
2 Attoye D. E., Tabet Aoul K. A., Hassan A (2017) A Review on Building Integrated Photovoltaic Façade. Customization Potentials	BIPV façade applications
3 Pelle M., Lucchi E., Maturi L., Astigarraga A., Causone F., (2020) Coloured BIPV Technologies: Methodological and Experimental Assessment for Architecturally Sensitive Areas	Product and manufacturer overview
4 Sánchez E., Izaola L., (2015) Performance of photovoltaics in non-optimal orientations: An experimental study	PV façade benefits
5 Munari M. C., Roecker C., (2019) Criteria and policies to master the visual impact of solar systems in urban environments: The LESO-QSV method	Visual impact of PV system
6 Norwood, Z., Theobaldt, I., Archer, D.E. (2016) Step-by-step deep retrofit and building integrated façade/roof on a 'million program' house	case study of BIPV façade for retrofit
reports	selected content
1 Zanetti I., Bonomo P., Frontini F., Saretta E., van den Donker M.N., Verberne G., Sinapis K, Folkerts W., Vossen F., (2017) Building Integrated Photovoltaics: Product overview for solar buildings skins. Status Report 2017	Customized products overview
2 Corti P., Bonomo P., Frontini F., (2020) Building Integrated Photovoltaics: a practical handbook for solar buildings. Status Report 2020	BIPV case studies
3 IEA SHC (2013) Designing Photovoltaics System for Architectural Integration. Criteria and guidelines for product and system developers, Task 41.A.3/2	Product and project overview
4 Kraubitz, T., Scheibstock, P., Guillen, G. (2018) Plus Energy Buildings and Districts, keystone papers 1 for GIZ's Sino-German Urbanisation Programme	case study of plus energy building with BIPV
5 IEA PVPS (2019) Coloured BIPV: Market, Research and Development, Task 15, Subtask E. 2019	PV Aesthetic features and technology
interview	topic
1 Pietro Florio / JRC, Scientific Research Project Officer	the role of applied research in BIPV technological innovation
2 Alessandro Virtuani / Senior researcher at EPFL & co-founder Officina del Sole	the importance of BIPV for European decarbonisation challenges
3 Pierluigi Bonomo / Researcher- Head of BIPV Advanced Building Skin Team at SUPSI	new formal configurations interpreted by architecture
4 Enrico Ferramondo Marchesi / innovation manager of living lab NEST, Zurigo	collaboration between research, industry and architects to speed up the transfer of BIPV within the market and the architecture
database	
1 solararchitecture.ch 2 bipv.ch 3 solaragentur.ch 4 bipv.eurac.edu/en	

Figure 68. Main analysed sources.

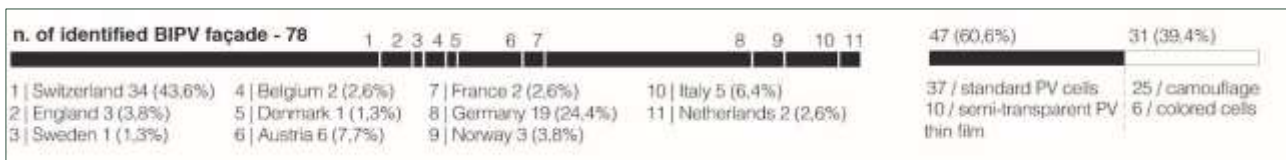


Figure 69. Analysis of the current state-of-the-art of BIPV integrated façades in Europe. Source: original graphics by Callegari G., Simeone P., Merolla E.

The POLITO-DAD research group is centred on developing and designing smart BIPV system building envelope components characterised by prefabrication, recyclability, and modularity.

In the context of the ARV project, these aspects are part of the ecosystem of the Autonomous Province of Trento, where the companies in the building sector are strongly oriented towards the development of industrialized products and off-site solutions for architecture, with particular reference to the engineered wood components sector. Therefore, the aim was to experiment, within the ARV project, with plant-systems integration in an industrialized building envelope system produced in a factory.

Incorporating a prefabricated envelope system and an industrialised product makes it possible to demonstrate the relationships between the various components, including the systems (PV, HVAC, etc.), the wall-window node, and the technologies for predictive monitoring, by analysing the design of the

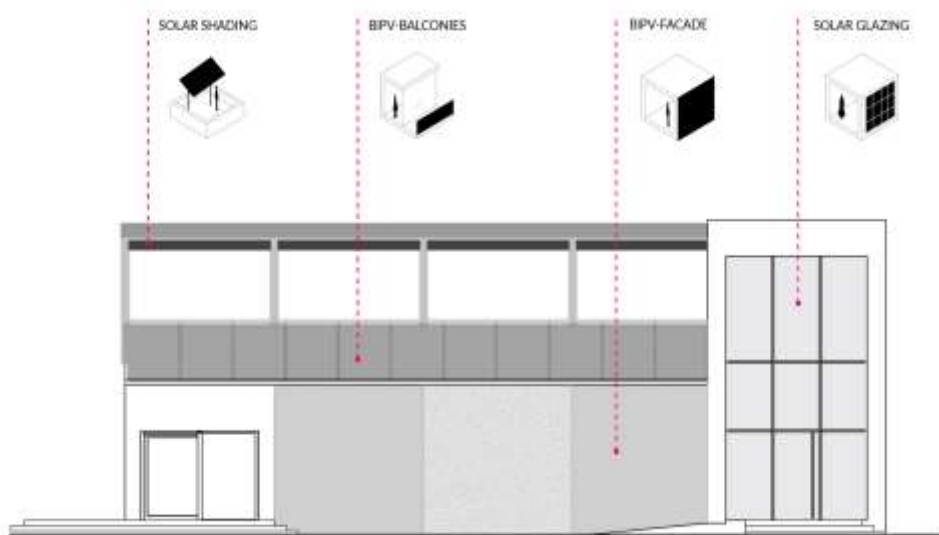
assembly-disassembly processes. Specifically, the innovation refers to a prefabricated PVT (solar photovoltaic thermal technology) module ready to be integrated into the building envelope as an active façade system.

The design of the prefabricated building solution guarantees efficient assembly/disassembly in external walls, easy maintenance, and possible integration of plant systems, thanks to fast and plug-in connections. At the same time, it guarantees air/wind tightness and water resistance, offering considerable adaptability to the various structural configurations of the façade. The PVT module is made using additive manufacturing processes, such as digital fabrication and thermoforming methods. Aesthetically, a unique coloured glass hides the solar technologies without filtering or blocking UV rays assuring both the solar and technological functions.

Preliminary energy analyses have been carried out by the Department of ENERGY (DENERG) of POLITO, through numerical models, in order to evaluate the behaviour of PVT technologies. Several full-scale mock-ups of the module have been produced to analyse the technical solutions and start testing the physical module's behaviour.

In order to experiment various BIPV technologies (**Figure 70**) on the New Building of Demo Project Trento, the POLITO-DAD research group has focused its work on the creation of a BIPV envelope mock-up, currently being monitored at the POLITO with the aim of making a significant contribution to the context of the experimental building in Trento. The technology is currently undergoing validation using a laboratory prototype (TRL4) with the collaboration of POLITO-DENERG.

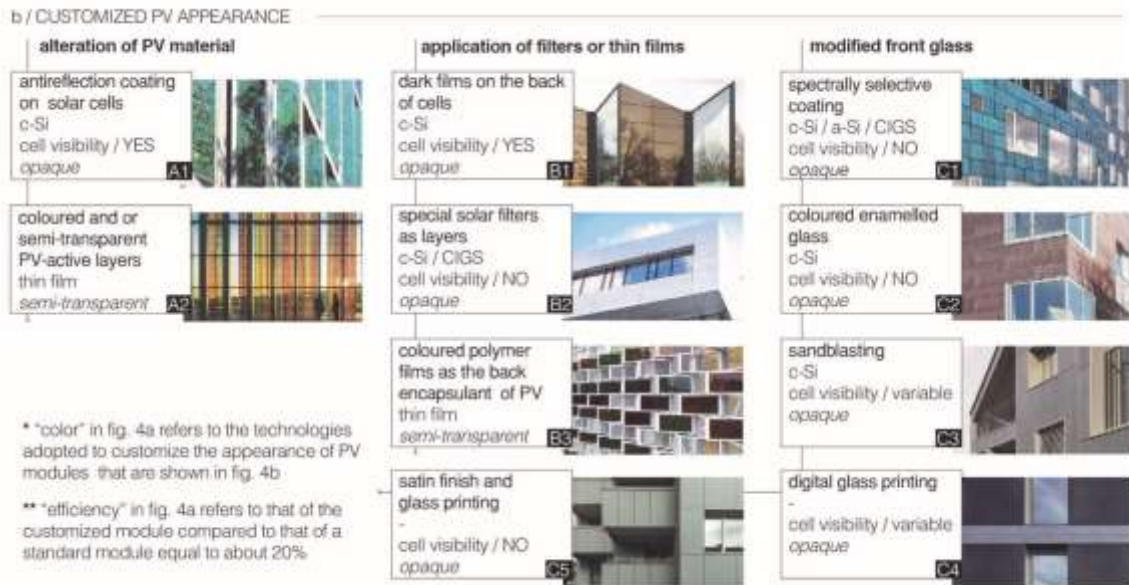
The technology will be integrated into Renew Wall system of Fanti Legnami Srl. The design of a BIPV technological envelope to be produced as an industrialized component in the factory will facilitate the logic of economies of scale in planning the final cost of the product, an aspect that today constitutes a deterrent to experimentation in many European countries. Therefore, the aim was to experiment, within the ARV project, with plant-systems integration in an industrialized building envelope system produced in a factory.



**Figure 70.** Photovoltaic integration forms identified on the envelope of the New Construction of the Demo Project Trento, South facade. Source: original graphics by POLITO-DAD.

In addition to having initiated this envelope project, has been developed more generally a study aimed at advancing design guidelines for the architectural integration of BIPV. The aim of this activity is to explore the ongoing process of integrating technical systems in the vertical building envelope, with particular reference to solar thermal and photovoltaic solutions. The experimentation of new solutions – accompanied in Europe by new standards on integrated building envelopes developed by the scientific community and partnerships between the PV industries and the glass sector – has had important

repercussions aesthetically and architecturally, resulting in a new generation of architectures representative of green deal challenges (**Figure 71**).



**Figure 71.** Products overview. The graphic illustrates the current colouring technologies for PV components and the range of different formal interpretations. Source: Original graphics by by Callegari G., Simeone P., Merolla E. [23].

The design guidelines for the architectural integration of BIPV will be completed in the coming months as a further contribution within the ARV project.

**INNOVATION #4:**

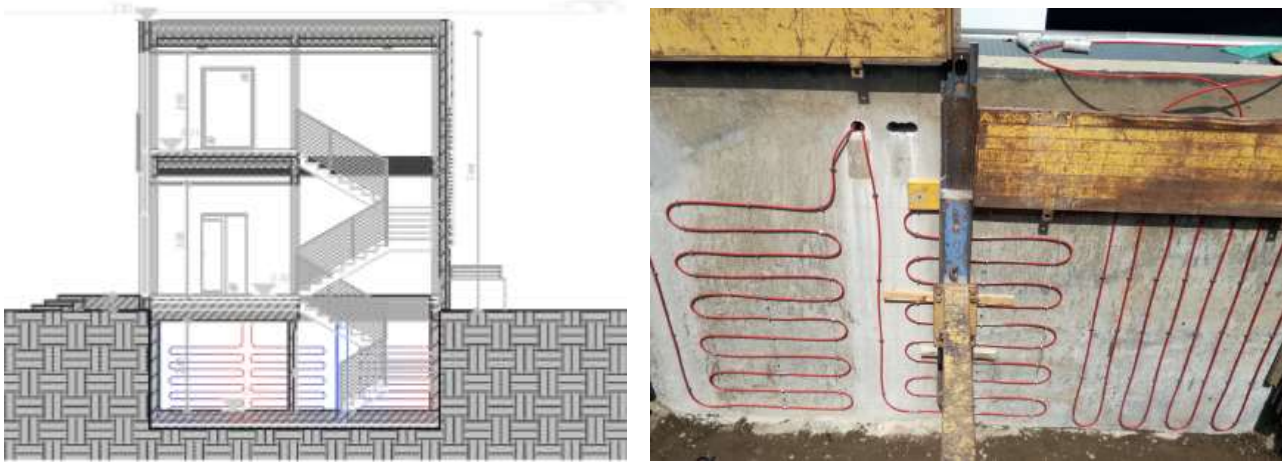
*Heat pumps integration for H&C (connection to NSGE – tunnels, building foundations, roads); passive heating systems integrated in buildings envelopes; active thermal mass, heat storage; active/passive systems integration via Building Automation Systems.*

Considering the new Building (ARV Hub in Piazzale ex-Zuffo), after several meetings with the system engineers and considering that: a) the building will be energetically positive; b) it can rely on several energy sources (geothermal electric, PV and BIPV, VMC), it has been decided to use an innovative multi-source heat pump (HP) to smartly integrate the different source. The main idea is to make available to the reversible HP a stable high-temperature source or low-temperature sink in heating and cooling respectively. For this reason, the choice of source will be studied using different regulation logics in order to maximize the system's performance while meeting the constraints on closing the annual energy balance of the source/sink. The system will be equipped with energy meters, as well as monitoring of the electricity produced by the photovoltaics. Then, a sufficiently large dataset of measurements will be collected to train machine learning models that are subsequently used to test predictive control logics.

In this context, a new energy wall system that broadens the application of the energy geostructures concepts to new construction is in Trento Demo Project proposed. Among the sources of the heat pump, an innovative shallow geothermal system, developed by the research group of the Department of Structural, Geotechnical and Building Engineering (POLITO-DISEG) will be installed (**Figure 72**). This system called "GeothermSkin" is a low enthalpy geothermal technology that uses the earth-contact area of the retaining walls of the building basements to exchange heat with the ground [24]. The system "consists in a hydraulic circuit made up of polymeric pipes fixed to the external surface of the retaining walls. A heat carrier fluid (essentially a water-glycol mix) circulates through them allowing for heat exchange with the ground. Modules can be linked in sequential or parallel combination to a main



collector and pipes can be deployed both in the horizontal and in the vertical direction” [25]. The exchange pipes are connected to supply and return pipes, which, in turn, are connected to the heat pump located in the thermal power plant serving the building.



**Figure 72.** GeothermSkin system conceptual applied to the New Building of the Trento Demo project (left) and installation phases of the GeothermSkin system prototype on an existing structure (right). Source: original graphics and photo by POLITO-DISEG.

This technology can be applied to both new constructions and buildings undergoing refurbishment. For new constructions, the system can be implemented taking advantage of the open excavations during the first stages of the construction. The thermal activation of the building can involve the underground basement walls and the foundation slab of the building. In the case of existing buildings (e.g. for energy retrofitting), excavation work may be needed to expose the wall surface before installation [26].

#### **INNOVATION #5:**

*Analysis of existing models for scenarios elaboration to inform hybrid Energy/Nature-based solutions on building/urban surfaces; innovative materials (new and waste/by-products).*

Considering the use of nature-based solutions on the building surfaces, innovative technologies and innovative materials, four innovative façade solutions have been designed on the South facade of the new building in order to make a comparison by means of an LCA analysis and an extensive monitoring campaign of their performances. In particular, four different solutions are considered:

- 1) Renew Wall panel with plaster finishing and a nature based inner insulating materials (under definitions by the DAD Group of POLITO).
- 2) Renew Wall panel with BIPV opaque coating, including an experimental PVT module for the pre-heating of inner air by means of a natural convective system generated by an absorber positioned in an air camera just behind the BIPV external panel, and connected to the indoor space by two ducts (inlet and outlet).
- 3) Renew Wall with external ventilated façade realised with wooden elements.
- 4) Renew Wall panel with a green wall solution composed by a structures that have rooted plants and feature an irrigation system programmed to meet the garden's needs.

The four walls will be monitored with a thermal flux meter and temperature wall sensors (inside, outside and within the wall) to measure the U value of the wall and performance both in winter and in summer conditions (heat storage, thermal lag, outdoor wall temperature for UHI effect, PVT performance vs MV Systems). An LCA and LCC analysis will be performed in order to define the environmental impacts of the solutions and their total costs.



## 8. BEST DESIGN PRACTICES AND CHALLENGES

---

Generally speaking, during the urban planning and the design stages, the experience may be either positive or negative. Both successes and critical steps or failures are considered sources of lessons learned.

The lessons learned in the first two years of the ARV project with particular reference for the Trento Demo Project are summarised below. Please consider that at this stage of the research project the design process concerning the New Construction and the Existing Building Refurbishment has not been fully developed. So, the following statements are preliminary and based on the experience occurred so far.

- 1) To **design not for people, but with people**. In the early stages of the design process it was important:
  - i) to build a team including people from different departments and organizations with different interests, competencies and backgrounds providing regular meetings (also online) in order to discuss step by step the design implementation;
  - ii) to develop a connection with all the possible stakeholders involved (including the end-user and the local population through citizen associations) with a democratic process, listening to their needs and taking into account their vision of the area also in connection to the history and to the perspectives (past and future);
  - iii) to implement a social engagement with a Living Lab focusing on "Social renovation" and "Energy transition". In fact, the best solutions come when input derive from different perspectives.
- 2) To **introduce the use of KPIs**. The aim includes the setting targets (the desired level of performance) and the tracking progress against those targets. KPIs are an analytical basis for decision making and help focus attention on what matters most. The assessment of some indicators is often subjective and cannot be easily calculated. The use of shared KPIs allows to control all the design phases (from the ECD onward) and to guide the activities of all the actors involved especially considering the technical choices to be done.
- 3) To **integrate** as much as possible the **different designer's competences** between them in order to achieve the best solution balancing technical requirements with costs.
- 4) To **combine different building solutions** also in order to maximise energy coming from RES, considering local potentialities of the site regarding the environmental conditions such as wind and solar radiation. The idea is that there is not only one solution to be applied as the best one, but that several technologies can work together in synergy if duly managed by a BES.
- 5) To **define and validate strategies based on digital procedures** to support renovation processes of the built environment. In particular, for the knowledge and representation of intervention objects, an experimental comparison among the acquisition and processing phases of three different strategies (LiDAR scans, photogrammetry and SLAM scanning) have been conducted. The strategies tested have been evaluated in the light of the accuracy of the results and their suitability for the scope of the project, but also taking into account their affordability and invasiveness. The results of the experimentation include the definition of possible workflows and potential application, aimed to be helpful for several among renovation processes.

## 9. ANNEXES

---

### 9.1 CATALOGUE OF INTEGRATED CIRCULAR DESIGN SOLUTIONS

---

### 9.2 NATURAL AND MECHANICAL VENTILATION CONCEPTS

---

### 9.3 OTHERS

---

9.3.1 Sheets of Destra Adige - Piedicastello district

9.3.2 Table of meetings with stakeholders for the New Construction (ECD)

9.3.3 Online survey

9.3.4 Summary report of the online survey

9.3.5 Paper published on Buildings journal

9.3.6 Preliminary analysis energy demand for the New Construction

9.3.7 Table of meetings with stakeholders for the New Construction (DD, DeD)

9.3.8 Design guidelines for the integration of PV in architectural design

9.3.9 Table of meetings with stakeholders for the Refurbishment (ECD, DD, DeD)

9.3.10 Refurbishment programme

9.3.11 Visual inspection and existing documentation for the Refurbishment

9.3.12 Thermographic survey for the Refurbishment

9.3.13 Geometric survey for the Refurbishment

9.3.14 Installation of sensors for envelope performance

9.3.15 Construction site for Refurbishment



CLIMATE POSITIVE CIRCULAR COMMUNITIES

## **ANNEX**

### **9.1 Catalogue of Integrated Circular Design (ICD) solutions**

**D4.5 DESIGN GUIDELINES OF CLIMATE POSITIVE CIRCULAR COMMUNITY IN TRENTO**

**WP4 SUSTAINABLE BUILDING (RE) DESIGN**

# Catalogue of Integrated Circular Design (ICD) solutions

Authors: UNITN e POLITO

## Index

<b>1. Context of the catalogue.....</b>	
<b>2. Climate-related challenges.....</b>	
2.1 Energy Sustainability .....	
2.2 Temperature regulation .....	
2.3 Sustainable water management .....	
2.4 Health and wellbeing .....	
2.5 Transition to circular system.....	
<b>3. The built environment.....</b>	
3.1 Energy sustainability .....	
3.2 Temperature regulation .....	
3.3 Sustainable water management .....	
3.4 Health and wellbeing .....	
<b>4. The solutions .....</b>	
4.1 Classification of surfaces .....	
4.2 Categorization of solutions .....	
4.3 Types of solutions to implement on buildings' envelopes .....	
4.4 Types of solutions to implement on ground .....	
4.5 Types of digital solutions .....	
<b>5. Towards an integrated framework for Climate Positive Circular Communities.....</b>	
<b>References.....</b>	
<b>Glossary of terms.....</b>	
<b>Legend icons &amp; symbols .....</b>	
<b>Acknowledgements and disclaimer .....</b>	



## 1. Context of the catalogue

The EU aims to be climate-neutral by 2050 – an economy with net-zero greenhouse gas emissions. This objective is at the heart of the European Green Deal and in line with the EU's commitment to global climate action under the Paris Agreement. All parts of society and economic sectors will play a role – from the power sector to industry, mobility, buildings, agriculture and forestry.

The construction sector has had a key role in contributing to climate change and currently accounts for 40 % of Europe's final energy consumption and 36 % of its CO<sub>2</sub> emissions. The European **Green Deal for the construction sector**:

- calls for the sector's potential for energy savings and carbon footprint reduction to be unlocked, by the objective set out in the Energy Performance of Buildings Directive of achieving a highly energy-efficient and decarbonised building stock by 2050;
- stresses that making the energy consumption of buildings more efficient holds substantial potential for further reducing Europe's GHG emissions;
- considers, that the achievement of low-energy buildings, fully supplied by renewable energy, is a sine qua non for the Paris Agreement and an EU agenda for growth, local jobs and improved living conditions for citizens across Europe.

In addition, other plans at the EU level were developed in the European Green Deal, such as **the Circular Economy action plan** (2020) and **Climate Adaptation Strategy** (2021).

From the point of view of Built Environment and Construction industry, the Circular Economy Action Plan has promoted:

- sustainability performance of construction products, including the possible introduction of recycled content requirements for certain products;
- measures to improve the durability and adaptability of built assets;
- revision of material recovery targets set in EU legislation for construction and demolition waste and its material-specific fractions;
- promoting initiatives to reduce soil sealing, rehabilitate abandoned or contaminated brownfields and sustainable use of excavated soils.

The Circular Economy Action Plan contributes to the long-term EU climate neutrality vision for 2050, but at the same time, the EU wants to be a climate-resilient society, fully adapted to the unavoidable impacts of climate change. This means that by 2050, when we aim to have reached climate neutrality, we will have reinforced adaptive capacity and minimized vulnerability to climate impacts, in line with the Paris Agreement and the proposed European Climate Law.

The 'renovation wave' initiative, introduced under the European Green Deal could usefully not only focus on energy savings in buildings but also promote adaptation to the increasing frequency and intensity of various climate hazards. Consideration of climate change impacts is needed in designing urban infrastructure (e.g. sewerage systems) and built environments (homes and workspaces) to ensure their functionality in the future.

To reinforce these policies and to materialize the objectives has been created a **New European Bauhaus** initiative has to connect the European Green Deal to daily lives and living spaces. It calls on all Europeans to imagine and build together a sustainable and inclusive future that is beautiful for our eyes, minds, and souls.

The initiative is:

- a bridge between the world of science and technology, art and culture;
- about leveraging our green and digital challenges to transform our lives for the better;
- an invitation to address complex societal problems together through co-creation.

The New European Bauhaus inspires a movement to facilitate and steer the transformation of our societies along three inseparable values:

- **sustainability, from climate goals to circularity, zero pollution, and biodiversity;**

- **aesthetics, quality of experience and style beyond functionality;**
- inclusion, from valuing diversity to securing accessibility and affordability.

The New European Bauhaus brings citizens, experts, businesses, and institutions together to reimagine sustainable living in Europe and beyond. In addition to creating a platform for experimentation and connection, the initiative supports positive change also by providing access to EU funding for beautiful, sustainable, and inclusive projects.

In this scenario are fundamental all the concepts and urban models developed and tested in the last years to transfer the policies into real action at urban, neighbourhood and building scales. Positive Energy Districts (PED), Sustainable Plus Energy Neighborhoods (SPEN) and Zero Emission Neighborhoods (ZEN) focus strongly on the interaction and integration between the buildings, the users, and the regional energy, mobility and ICT systems. Climate Positive Circular Communities (CPCC) concept proposed in this EU project, adds some characteristics beyond, also including socio-environmental aspects and highlighting circularity as a key aspect.

The present catalogue of integrated circular design solutions aims to collect and systematize the available design measures to respond to the effects of climate change and to reduce greenhouse gas emissions in built environment. At the same time, the catalogue explores the digital solutions that could support policymakers, architects, urban planners and technical practitioners in all the life cycle construction stages and the environmental challenges highlighted for the development of Climate Positive Circular Communities (CPCC).

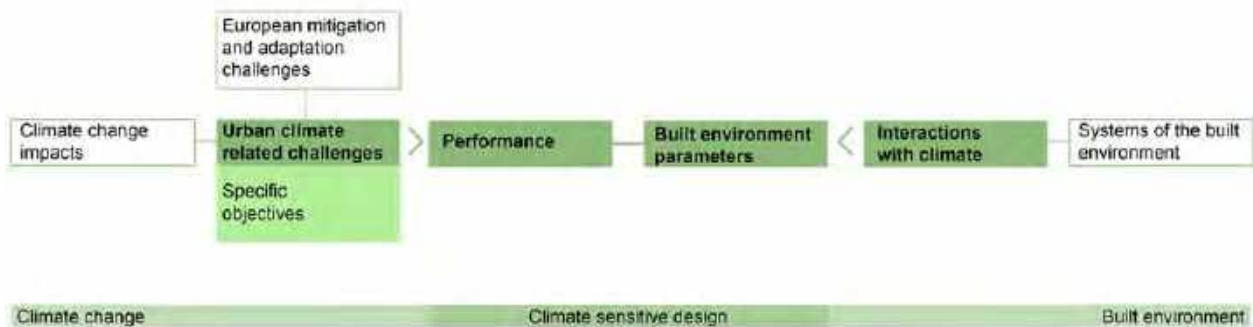
## **2. Climate-related challenges**

In the current scenario of urbanization and urban population growth, cities need to move towards a better and healthier quality of urban life. The increase of built-up areas and energy demand have been exacerbating the causes and the impacts of climate change. On one hand, cities represent one of the major contributors to climate change and CO<sub>2</sub> emissions; on the other hand, they are vulnerable to the impacts of climate change. Temperature increase and extreme events, such as floods, water scarcity and heat waves, are the cause of health risks as well as issues to services and infrastructures. The relationship between cities and climate change have been widely discussed by European and International policies, for example by the SGD 11 of the United Nations and by the European Urban Agenda.

To face such challenges, the built environment should not merely reduce the impacts of new developments, rather contribute to repairing human and natural ecosystems, by shifting from a less bad impact to a positive impact through regenerative design. In this view, strategies of mitigation (i.e. reducing greenhouse emissions) should be integrated with climate adaptation ones (i.e. capacity to recover and creation of a healthy baseline, to facilitate more liveable cities for people). As highlighted by the 2030 Agenda, energy issues of the built environment are connected to its environmental performance and to human centred health and wellbeing considerations. However, current practices lack a systemic approach capable of integrating several functions and issues, and are unable to tackle simultaneously different challenges. Thus, implementing a regenerative approach for urban transformations could constitute a good asset for this purpose, and improve the relationship between humans and the built environment, by creating a framework that considers building energy performances, environmental impacts, resilience to climate change and human needs (Raven et al., 2018).

Considering the main impacts of climate change in urban areas and the reports on the local situation, five main issues have been identified: Energy Sustainability (ES), Temperature Regulation (TR), sustainable Water Management (WM), inhabitant's Health and Wellbeing (HW) and Transition to Circular System (TCS).

The proposed approach is based on *challenges* rather than objectives, allowing flexibility and continuous development of strategies and tactics as well as freedom in the choice of the specific solution. Each challenge is further developed by *specific objectives*. They identify the urban transformation actions that can be implemented to tackle the challenges, according to the location and conditions. The performances constitute the drivers to achieve the specific objectives, driven by enabling processes of the built environment. As such, performances can be measured and controlled by practitioners. Designing through a climate sensitive approach relies on the understanding of the relationship between the built environment and urban climate and on the management of parameters and interactions between them.



## 2.1 Energy sustainability

A great amount of energy in the EU is consumed by the built environment, for electric appliances, heating and cooling systems, causing around 50-60% of the total greenhouse gas emissions and consuming about 75% of global primary energy.

Regenerating the built environment constitutes a key action to limit greenhouse emissions and to contribute to climate change mitigation. The three main actions promoted by European policies in the built environment are: production of local energy from Renewable Energy Sources (RES), retrofitting the built environment to improve energy performances, and reducing emissions by energy saving (European Commission, 2018). Moreover, an important aspect for energy transition is to consider the interactions of the urban environment at the neighbourhood level, rather than the optimization of energy of the single building, as in the concepts of Positive Energy Districts PED (JPI Urban Europe) or Net-Zero Energy Districts (Saheb et al., 2019). The following objectives are necessary measures for the energy transition of the built environment: reduction of the energy demand for the operation of the building by energy efficiency; increase of energy produced locally from RES; reduction or offset of carbon emissions. Specifically, for urban transformations, energy efficiency can be achieved through passive technologies in the buildings, as well as through the use of efficient devices. In the urban environment, the most common RES is solar power, which relies on environmental conditions (i.e. solar radiation) and on the geometry of the built environment. Finally, carbon reduction is mainly addressed indirectly by reducing the need to cool or heat, and directly by strategies of carbon offset, such as reforestation.

## 2.2 Temperature regulation

The relationship between urban climate and humans is complex. Urban outdoor spaces usage is directly related to the outdoor thermal comfort (Nikolopoulou 2007). The outdoor thermal environment is facing three challenges: global warming, urban heat islands and heat waves. Urbanisation, and specifically

densification, led to the phenomenon of Urban Heat Island (UHI), which consists of higher temperatures in the urban areas compared to the surrounding rural ones. Its main causes rely on morphological and physical characteristics of the built environment, as well as anthropogenic factors such as traffic and cooling systems. Moreover, UHI is exacerbated by global warming and heat waves, being a risk for human health and comfort (Oberndorfer et al., 2007). Therefore, to address temperature regulation in the design practices, the focus should be both on reducing the UHI effect and improving local microclimate conditions.

The human body exchanges heat with the surrounding environment through convection, radiation, evaporation and conduction. To determine the heat transfer between the human body and the thermal environment, quantitative factors can be used related to the physical characteristics of the person (such as clothing and activity) as well as physical parameters of the environment. The main parameters to describe the urban thermal environment are humidity, thermal radiation, wind speed and air temperature. Thermal radiation in an open space is normally described through mean radiant temperature ( $T_{mrt}$ ), which is the sum between long-wave and short-wave radiation. Short-wave radiation includes direct, diffuse and reflected solar radiation from the sun; long-wave is the radiation from the sky and solid surfaces, such as buildings, and it is commonly indicated by the surface temperature (Lai et al., 2019).

### **2.3 Sustainable water management**

Integrated water quality and quantity management is becoming an important issue in recent years. Urbanisation and uncontrolled growth of soil sealing increased water demand as well as difficulties to manage stormwater. Moreover, the intensification of extreme rainfall events can be catastrophic to cities, damaging infrastructures and causing loss of lives. Hence, the traditional management of water, based on directing runoff to waterways through the sewer system, has shown difficulties to respond to recent phenomena. In the last years, European and national policies have been promoting diffuse systems of rainwater management which consider water as a resource and are based on localised and diffuse lamination, natural depuration, water reuse and infiltration in the soil (Charlesworth and Booth 2017). Water is therefore not quickly collected into pipes, but infiltrated and detented into surfaces on site. This approach contributes to maintaining hydrological balance as well as improves biodiversity in the urban environment. Being based on the maintenance of hydraulic invariance, sustainable water management can be pursued through land use transformation, by integrating vegetation and pervious surfaces capable of infiltrating, retaining and purifying runoff (Vera et al., 2017). Such solutions, namely Sustainable Urban Drainage Systems (SUDS) aim at managing rainwater to reduce damages from flooding, to improve water quality, to protect the environment and health, to ensure stability of drainage systems (Booth and Colin, 2016). Giving equal emphasis on water quantity and quality, the specific objectives of the Sustainable Water Management (SWM) challenge are to decrease runoff volume, to reduce the risk of flooding, mitigate water scarcity, and improve water quality. SWM can play an important role in guaranteeing a more circular management of water streams in urban areas.

### **2.4 Health and wellbeing**

Several scientists have clarified that climate change and global warming have been impacting human health, affecting morbidity and mortality, especially for urban citizens (Cedeño et al 2018). Actions are therefore needed to mitigate such impacts, guarantee safe and healthy living conditions, support healthier lifestyles and reduce exposure to stressors (Marselle et al., 2019). However, a shift from the “Healthy cities” towards the “Salutogenic cities” is driving the focus towards health promotion (Capolongo et al., 2018). According to the salutogenic orientation, the focus is directed towards health promotion (i.e maintaining health, strengthening health resources and establishing health-promoting environments) rather than towards health protection (i.e preventing potential health risks and diseases) (Rittel et al., 2016). In this framework, the health and wellbeing challenge, therefore, refers to actions aiming to experience good health and quality of



life (Lindström & Eriksson, 2011; Maass et al. 2017). Specifically, urban regeneration strategies can improve social quality of life, livability and health, by making urban spaces more attractive (Taleghani et al., 2018). For this purpose, design practices, at any scale (city, neighbourhoods, buildings), should promote sociality, integration and inclusion as well as wellbeing, health and accessibility. In general, the aim is to promote actions ensuring safe and comfortable conditions, both from a physical and psychological point of view, and a sense of belonging. Healthy cities, as intended by the WHO, in line with the salutogenic principles, focus on the community as a whole rather than on single individuals (WHO 2012).

Cities, communities and neighbourhoods represent settings to improve comfort and quality of life (Biddle and Seymour, 2012), as they refer to identity, social entity, collective action. In particular, they represent: the mix between built environment and natural places shared by people; the collective identities or shared visions that define a sense of community; the social entities within people feeling integrated and that share a collective wellbeing; the resilience and pro-active forms of residents participating in the community life (Vaandrager and Kennedy, 2017). In this view, to tackle the challenge of health and wellbeing, a twofold attention should be carried on quality of life and on the quality of the urban environment.

## **2.5 Transition to circular system**

Built Environment is characterized by many components that in the last years have contributed to increase the impacts anthropic activities on environment processes and on climate global and local dynamics. In particular construction sector in most industrialized countries, has consumed 50% of all materials (Herczeg et al., 2014), determining 36% of the total waste in European Union (Eurostat, 2021) contributing to the 39% of global energy related greenhouse gas emissions (IPCC, 2018) due to the its linear model, characterized by extraction, production, use, and discard of building materials. For example, concrete represents around the 8% of global CO<sub>2</sub> emissions and the second most consumed substance after the water (Scrivener, 2020).

Instead, the construction industry intends as a wide range (construction of buildings, infrastructures, streets, open air spaces) is called to urgent action to reduce the use of primary resources, to reduce waste production, to reduce energy consumption and related greenhouse gas emissions, in the perspective to shift from a linear system to a circular system.

Circular Economy concept was discussed by many authors and practitioners, yet from the second half of previous century. In the last years has gained a public attention thanks to the effort produced by Ellen MacArthur Foundation and by ARUP (2016), that have published a report on the Circular Economy in the Built Environment. As report by ARUP (2016) and adapted from Ellen Mac Arthur Foundation, the two main pillars of Circular Economy thinking are the combination of biological cycle and technical cycle to minimize systematic leakage and negative externalities through the application of six actions aiming to the transition to circular economy system. Regenerate, Share, Optimize, Loop, Virtualize, Exchange can be applied to products, buildings, neighborhoods, cities, regions, or even to entire economies. Virtualization and Exchange are actions that could benefit from the support of digitalization in order to overcome the lack of communication and coordination along the entire process to achieve a coherent implementation of circular strategy in Built Environment.

Digital transformation, as well as Circular Economy is one of the priority area for EU policies development (European Commission, 2021) until 2030. This goal enhances the investments not only for people and businesses but also for climate neutral, circular and resilient economy. As reported in the EU Circular Economy Action Plan (European Commission, 2020), innovation and digitalization can support the transition from linear to circular system, through tracking, tracing, and mapping for example. As reported by Çetin et al. (2021), there is a clear link among digital transformation and Circular Economy in the policy and practices environment in European context.

As argue Campell-Johnston et al. (2019) the implementation of challenges link to Circular Economy at city scale are scarce investigated and studied, as well as the involvement of monitoring systems. The main

challenge for built environment to reduce its impacts in terms of natural resources consumption, energy consumption and greenhouse gas emissions is the transition to circular system. In this perspective, the main objectives necessary to achieve this goal are: circularity of infrastructures and buildings (De Filippi & Carbone, 2021) and circularity of products and materials (De Filippi & Carbone, 2021). The assessment of structures built and demolished or the quantification of abandoned structures in built environment are fundamentals to support the transition of infrastructures and buildings. The analysis of potential re-use and recycling of materials, the inventory of exterior buildings and infrastructures materials and the mapping of properties for demolition are key performances able to satisfy the transition to circular system of materials and products of Built Environment.

### **3. The built environment**

The present paragraph focuses on the relationship between the climate-related challenges and the built environment. It relies on the definition of systems of interactions and *enabling processes*, which are properties of the urban components interacting with urban climate. Defining the enabling processes allows the definition of measurable *performances* to address the specific objectives through urban transformations. The built environment is seen with a multiscale perspective, defined by the interactions and dynamics between natural systems, inhabitants and urban components. Buildings, streets and open spaces are not individual objects, but the parts of a system, in which for example, the envelopes are the diaphragm between indoor and outdoor. As a matter of facts, the properties of the materials used for the building envelopes and outdoor spaces play a bifold role in the thermal response and environmental impact of the built environment: they affect the energy demand to guarantee indoor comfort, and they have an impact on the urban microclimate, affecting both outdoor and indoor comfort. The effectiveness of solutions on the climate-related challenges is different and depends on several factors, such as the location, the type of soil, and urban compactness (Garshasbi et al., 2020, Natanian and Auer, 2020). For this reason, the choice of the specific solutions depends on the area of study

#### **3.1 Energy sustainability**

Given the bifold role of the built environment, energy sustainability can be reached directly, through actions on the buildings aiming at reducing carbon emissions and energy consumption, as well as indirectly through actions in the urban environment improving the local microclimate and mitigating overheating. The latter will be explained in the Temperature Regulation challenge, therefore, it will not be considered in this section. The former depends on the materials used for the built environment and on the energy systems provided. To reduce the energy demand of the building stock, both passive and active strategies can be adopted: the improvement of the building's thermal response, to limit the use of energy, and the production of energy from renewable energy sources. A series of norms and standards (e.g. Living Building Challenge, WELL) as well as research frameworks (e.g. Zero Energy Buildings, Zero Energy Neighbourhoods, Positive Energy Districts) have been developed to foster the reduction of energy demand both for new and retrofitted buildings. The thermal response of the building can be controlled by passive strategies using building design to collect sun's heat, limit heat loss, reducing the need for heating, and to improve indoor comfort by ventilation, reducing the need for cooling.

To limit the proposed solutions to urban surfaces, the production of renewable energy can be addressed by the use of solar and photovoltaic panels, producing thermal and electrical energy. Such solutions can be applied to existing surfaces (BAPV) as well as integrated in the buildings' envelopes (BIPV). The solar power

generation depends on the location and on the amount of exposed surfaces not shaded by surrounding elements.

In parallel to the Zero Energy objectives, the limitation of carbon emissions is envisaged, considering operational and embodied carbon emissions of the built environment. Indeed, standards and research frameworks (e.g. Carbon neutral, Low carbon) have been addressing the issue by extending the reduction of GHG emissions associated with operational use, raw material extraction, manufacturing and processing, transportation, and installation of materials. In this case, carbon emissions can be reduced by a responsible selection of carbon sequestering materials, and by offsetting associated emissions.

Specific objectives	Performances	Enabling processes	Example
Reduction of energy demand	Energy efficiency for cooling	Thermal response (Thermal transmittance, reduction of solar radiation, natural ventilation, air permeability, dissipation)	Trombe wall
	Energy efficiency for heating	Thermal response (direct solar radiation, reduction of heat loss, air tightness)	Wintergarden
Minimising carbon impact	Low carbon material use	Carbon sequestration	Insulation
	Greening		Urban forests
Energy production from RES	Energy from RES on site	Global solar irradiation	BIPV

### 3.2 Temperature regulation

The built environment can be categorised as four systems interacting with urban climate: urban geometry, vegetation, water bodies and surfaces. The physical parameters used to describe the thermal environment are air temperature, thermal radiation, wind speed and humidity. They are independent from each other, but they can be integrated to calculate equivalent temperature, which is a parameter used to evaluate outdoor thermal comfort. The Temperature Regulation challenge can be tackled by intervening on ventilation, shading, albedo, use of greening and evapotranspiration. Changing such characteristics can reduce surface and air temperature, improve outdoor thermal comfort and block solar radiation, thus reducing the UHI effect and improving local microclimate.

Urban geometry is the tridimensional shape and layout of the built environment and urban fabric. The effects of urban geometry on the thermal environment are the modification of radiative and convective heat exchange. The reduction of solar radiation, more long-wave radiation from the buildings, and less wind speed

are the results of high and dense urban geometries. This parameter is normally defined by the sky view factor (SVF) for open spaces and blocks, and by the height-to-width ratio (H/W) and orientation for streets.

Green infrastructure, defined as the network of green spaces in the built environment, such as green walls, parks, trees along the streets, contributes to climate resilience, health and wellbeing of the inhabitants (Demuzere et al., 2014). In addition, vegetation in urban areas improves the quality of urban life.

The primary effects of vegetation on the urban thermal environment are block of radiation (shading), reduction of wind speed and air temperature. By reflection and absorption, trees can remove a great amount of short-wave solar radiation. Moreover, due to transpiration, vegetation reduces long-wave radiation, and therefore surface temperature. Trees increase the roughness of urban surface, reducing urban airflow. However, the reduction of airflow is different from the one caused by geometry, due to the porosity of trees. Vegetation reduces directly the temperature of the surrounding air by evapotranspiration (Oke 2002) and indirectly by shading, and it increases humidity by evapotranspiration. Such effects contribute to the improvement of thermal comfort.

Blue infrastructures, meant as the system covered and uncovered waterways in urban areas, contribute to outdoor thermal comfort. Water reduces the air temperature of the surrounding areas by evapotranspiration and increase of wind speed (Kleerekoper et al., 2012).

Urban surfaces influence UHI by absorbing solar heat (Santamouris, 2013). Their effect can be positive if the materials have high solar radiation reflectivity or if they are pervious. Surfaces with high albedo reflect solar radiation reducing surface temperature as well as air temperature. Despite the positive effect on surface and air temperature, many studies showed an increase of discomfort due to the reflection of solar radiation on the human body. The effects of pervious surfaces can be associated with the ones of green infrastructures, but with different degrees of effects.

Specific objectives	Performances	Enabling processes	Example
Improve local microclimate	Improve Outdoor Thermal Comfort (OTC)	Convection Radiation Evapotranspiration Conduction	Pocket gardens
	Shadow effect		Cool roofs
Mitigate UHI	Reduce surface temperature and air temperature (UHI intensity)		Trees along the streets

### 3.3 Sustainable water management

The measures related to the Sustainable Water Management challenge include hard constructions such as porous pavements and rainwater harvesting, and soft measures using nature-based solutions (e.g. green roofs, constructed wetlands, swales). The enabling processes of the water cycle, describing the behaviour of water entering the urban systems as precipitation, are conveyance, infiltration, detention, retention, evapotranspiration, and treatment (Langergraber et al 2021). The parameters influencing these processes



are permeability, water storage capacity and greening. For example, the use of pervious surfaces re-establishes more natural water balances, reduces runoff peaks and volumes and facilitates infiltration, retention and evapotranspiration. The application of urban greening contributes to groundwater recharge through infiltration processes and to water holding capacity of natural land upstream of urban areas. Sustainable water management strategies can be fostered by using greenery, water storage and soil filtration, allowing temporary water retention, storage and reuse of rainwater, and improvement of water quality. To reduce runoff, Sustainable Urban Drainage Systems are measures implemented at different scales (i.e. surface water management train): prevention (land use planning), source control, site control and regional control (Woods Ballard et al. 2015)

The systems of the built environment interacting with the water streams are: green infrastructure, hard surfaces, blue infrastructures and devices (e.g. rainwater harvesting and water butts). To achieve the specific objectives related to the SWM challenge, the built environment should provide the following performances: water retention, water treatment and recovery and reuse. The performances are enabled by different physical, biological and chemical processes or by reusing and recovering water. Such processes to restore and maintain the water cycle are: conveyance (i.e. water transportation), infiltration (i.e. water flow through the ground surface into soil), detention (i.e. temporary storage of precipitation), retention (i.e. permanent storage of precipitation), evapotranspiration (i.e. water transferred from the soil to the atmosphere by evaporation and plant transpiration). The processes for water treatment (change of physical and chemical properties), recovery and reuse are: sedimentation (i.e. settling and depositing suspended matter by gravity), filtration (i.e. passing a liquid through filter medium), uptake by plants (i.e. transfer of substances from the environment to plant), biodegradation (i.e. biochemical transformation of substances), photo-degradation (i.e. process of degradation of substances exposed to sunlight ultraviolet radiation), sorption (i.e. adsorption and absorption) and reuse (Langergraber et al 2021).

Specific objectives	Performances	Enabling processes	Example
Runoff mitigation	Water retention	Conveyance	Rainwater harvesting Bioswales
		Infiltration	Pervious pavement Infiltration strips
		Detention	Water squares Rainwater harvesting Intensive green roof
		Retention	Retention pond
		Evapotranspiration	Vegetated pavement Intensive green roof
Water scarcity mitigation	Water storage and reuse	Reuse	Water butt Green facade
Improve water quality	Water treatment	Sedimentation	Rain garden
		Filtration	Vegetated pavement Wetland

		Uptake by plants	Vegetated pavement Intensive green roof
		Biodegradation	Treatment wetland
		Photo-degradation	Wet retention pond

### 3.4 Health and wellbeing

As mentioned above, according to the salutogenic orientation and to the conceptual definition of community, urban transformations can address health and wellbeing of the inhabitants. The WHO recognizes the influences that indoor and outdoor living conditions have on public health (WHO): many physical characteristics of cities can play an important role on how people perceive the place and how people live the space. Firstly, neighbourhoods should be the places in which people identify with and for which they feel a sense of belonging. Similarly, the concept of sense of community, related to the experience rather than to the physical attributes or structure, is a significant factor for one's health (Mc Knight and Block 2010). In this regard, access to nature and places where to practise community life (e.g. community gardens, playgrounds) are associated with satisfaction. However, the effects that the solutions have on health might be different according to several conditions, such as dimension, condition of the green areas or satisfaction about the living environment. Secondly, communities represent collective identities (Vaandrager and Kennedy 2017), sharing an interest or sets of circumstances. Thirdly, neighbourhood cohesion defines the social entity of a neighbourhood and refers to the creation of collective wellbeing of a community and to the reduction of conflicts (Robinson 2005). The evidence, in general, is that people with stronger social connections tend to be stronger and healthier (Marmot et al. 2010). As social capital is essential for salutogenic communities, creating spaces for connections between individuals with different social identity is linked to wellbeing. Fourthly, community resilience is the ability of individuals and communities to cope with challenges and has a key role in health promotion. Pro-action, with its various forms of participation by individuals, brings people together and increases their role in taking decisions for their living environment.

In a salutogenic view, communities and neighbourhoods improve their health through generalised resistance resources (i.e. sense of belonging, sense of community, cohesion) to tackle the everyday stressors (Vaandrager and Kennerdy, 2017). To support communities' health and wellbeing, the built environment and public spaces can have a positive impact, through easy access to green space, community gardens, places where to meet and being active together. Moreover, walkability - meant as the intention to make roads and transport routes less stressful - contributes to health and wellbeing. The link between biodiversity and health (physical and mental) has been widely recognized (WHO & CBD, 2015, Marselle et al., 2019) and several practices have been exploring nature-based solutions and green and blue infrastructures to combine adaptation to climate change and human health. Such examples can also contribute to the provision of ecosystem services, such as air quality, and resilience to extreme events (Vaandrager and Kennerdy, 2017). Besides these practices, traditional risk reduction strategies remain important and can be addressed by providing shade and shelter in open areas.

Specific objectives	Performances	Enabling processes	Example
Improve comfort and life quality	Green space	Contact with nature	Green facades
Improve quality of the urban space	Space for socialisation	Sense of community	Pocket gardens
	Air quality	Risk reduction	Urban forests
	Walkability	Sense of belonging	Infiltration strips

The effectiveness of solutions on the climate-related challenges is different and depends on several factors, such as the location, the type of soil, and urban compactness (Garshasbi et al., 2020, Natanian and Auer, 2020). For this reason, the choice of the specific solutions depends on the area of study.

#### 4. The solutions

Urban surfaces have a key role to tackle the climate-related challenges and they influence quality of life as well as environmental conditions (Croce and Vettorato, 2021). For example, soil sealing influences the microclimate conditions and the infiltration capacity, increasing surface temperature and run off. Moreover, artificial surfaces contribute to the reduction of green areas, limiting walkability and spaces for socialization. Given their role in contributing to climate adaptation and mitigation, urban surfaces have received increasing attention in the last years. In this view, strategies of desealing have been promoted in open spaces, as well as retrofitting buildings with green roofs. The contribution of urban surfaces is not only limited to addressing climate change, as they provide functions related to resilience and sustainability, such as habitats and biodiversity preservation, food security, and freshwater availability (Croce and Vettorato, 2021). However, most of the studies are mainly sectorial. For example, they focus on single solutions (e.g. Pisello, 2017) or on single purposes, such as mitigation (e.g. Taleghani et al., 2018). Some recent studies investigate scenarios combining adaptation strategies and mitigation techniques (e.g. Garshasbi et al., 2020), or integrating different challenges related to buildings' energy performances (e.g. Natanian and Auer, 2020). Moreover, other studies propose processes to assess an integrated approach through digital tools, such as Naboni et al. 2019 and Mauree et al. 2019. However, such studies focus on the relationship between energy performances and outdoor temperatures, excluding the impacts of solutions on water management. The catalogue of solutions proposed in this study aims to overcome such limitations, by highlighting which solutions are available and which climate-related benefits they provide. In this view, the suggested solutions consider the urban components as a diaphragm, giving attention to the twofold effects of urban components on the indoor and the outdoor environment.

As promoted by the SDGs and JPI, urban transformations should shift from mono-disciplinary perspectives to holistic approaches enhancing relationships between natural systems, built environment and inhabitants. Such a shift entails a network between several disciplines related to planning and design and interdisciplinary system thinking. To control an integrated approach, framing common goals is essential to develop climate positive circular communities, and parametric design methods can facilitate the optimization of solutions. Indeed, strategies of adaptation and mitigation can have incompatibilities due to different temporal and spatial scales, the involvement of different stakeholders, and the complexities in the measurement and assessment of adaptation policies. This could lead to conflicts or trade-offs that need to be coordinated by a

common vision, for example the physical space requested by the implementation of nature-based solutions against the concept of densification. However, this conflict can be solved by the promotion of multifunctional surfaces. Moreover, many surface solutions for buildings and open spaces can strengthen the synergies between challenges. For example, nature-based solutions provide temperature reduction as well as carbon sequestration; passive technologies in the buildings improve indoor comfort, reducing energy needs. Recognizing the conflicts and synergies can facilitate the implementation of a holistic approach. For this purpose, the catalogue of solutions aims to highlight which solutions are available and which climate-related benefits they provide. Given the complexity of urban surfaces, in this study we present surface solutions to be applied to the external part of the envelopes and some outdoor solutions.

#### 4.1 Classification of surfaces

The types of urban surfaces available for transformations are both on ground and buildings' envelopes. Ground surfaces include linear elements (e.g. streets) and open spaces (e.g. parking lots), while buildings' surfaces are divided between roofs, facades and additional tridimensional elements.

Type of surface	Classification
Envelopes	Roof
	Facade
	Add-on
Ground	Street
	Open space

*Classification of the built environment surfaces*

#### 4.2 Categorization of solutions

The collected solutions have been categorised as follows: Urban Green Infrastructure, Blue Infrastructure, Energy Systems, Shading devices, Building technologies. Each category is further divided in sub-categories, according to the type of solution.

##### Urban Green Infrastructure (UGI)

UGI provides many ecosystem services (e.g. balancing water flows, providing thermal comfort), contributing to ecosystem resilience and bio-physical, social, psychological benefits (Demuzere et al., 2014). It constitutes an infrastructure of built systems and green spaces, including large-scale elements such as wetlands, forests, parks, and small-scale elements such as green roofs and green facades.

##### Blue Infrastructure (BI)

BI provides benefits in sustainable water management as well as in cooling, through evaporation. It includes: natural water surfaces, such as rivers and lakes; artificial surfaces, such as canals; techniques like spaying and water curtains, which can be applied to ground surfaces as well as to buildings (Croce and Vettorato, 2021).

##### Energy systems (ES)

ES include systems in urban areas locally generating energy from RES, to meet energy requirements (heating, cooling, electricity, hot water). Clean energy in built-up areas is mostly produced by active solar systems, applied in buildings' surfaces or on-ground, as well as by grid systems that connect multiple buildings.



### Shading devices (S)

S include solutions to protect from direct solar radiation, adapting to the rise of temperature and reducing the buildings' energy needs. Shading devices solutions can be applied to buildings surfaces, as well as to open spaces.

### Building Technologies (BT)

BT refer to the adaptive technologies, which rely on passive design to improve building energy efficiency and, indirectly, outdoor thermal regulation. These solutions include the techniques applied to buildings' envelopes to encourage natural ventilation and maximize direct solar gains.

Code	Category	Sub category
UGI	Urban Green Infrastructure	Wet Green-Building Productive Functional Recreative
BI	Blue Infrastructure	Devices Water surfaces Evaporative
ES	Energy systems	Solar active Grids
S	Shading devices	
BT	Building Technologies	Reflective materials Passive Technologies Innovative facades Pervious surfaces

*Categorization of solutions*

### 4.3 Types of solutions to implement on buildings' envelopes

The solutions suitable for the building envelopes are defined and categorized considering the above mentioned categories (described in 4.2) and the synergies of the climate-related challenges (section 3).

The solutions belonging to the UGI category can be integrated into the building envelope, both in vertical and horizontal elements. For example, green roofs can be applied to both flat and sloped roofs. According to the thickness of the growing medium, the green roof can be intensive, extensive and semi-intensive. Vertical greening systems can also be classified into living walls and green walls according to the growing techniques. Green elements of the buildings provide benefits both at the city and at the building scale, as they improve the thermal behaviour of the building and contribute to reducing temperature, mitigating the UHI effect, sustainable stormwater management and improving air quality. Moreover, by increasing the green spaces in the urban areas, they contribute to the health and wellbeing of the inhabitants and biodiversity.

BT include those materials or paintings that improve the building's behaviour, by reducing absorption of solar radiation or maintaining lower temperatures. Reflective materials, known as cool materials, have high solar reflectivity and infrared emissivity reducing surface temperature. Cool materials are generally applied to roofs to avoid glare issues through membranes, coating, paintings, tiles, but they can be used also in the facades. Cooling technologies, besides contributing to temperature regulation, contribute to the reduction of greenhouse gas emissions, by lowering the need of cooling. Moreover, passive technologies are part of BT solutions as they improve the building behaviour, for example by increasing the thermal mass of the wall. Finally, innovative facades technologies can be responsive and reactive to external conditions.

Belonging to ES, active solar systems (solar thermal and photovoltaics) can be applied to the surfaces of buildings, both on the roofs and on the facades. They can be either applied on the external surfaces or integrated as a cladding material.

Type of surface	Category	Solutions	Climate-related challenge addressed			
			ES	TR	SWM	HW
Roofs	UGI	Green roof	X	X	X	X
	BT	Cool roof	X	X		
	BT	Ventilated roof	X			
	ES	Solar thermal panels	X			
	ES	Yellow roof	X			
Facades	BT	Thermal insulation	X			
	UGI	Green wall	X	X	X	X
	UGI	Green facade	X	X	X	X
	BT	Cool wall	X	X		
	BT	Trombe wall	X			
	BT	Glass with solar control	X			
	BT	Adaptive skin	X			
	S	Sunshade	X			
	BT	Phase changing materials	X			
	BT	Ventilated facade	X			
	BT	Double skin	X			
	BT	Natural ventilation	X			
	BT	Night cooling	X			
	ES	BIPV/BAPV	X			
	ES	Solar panels	X			
Add-on	UGI	Productive façade system	X	X	X	X
	UGI	Vertical farming	X		X	X
	BT	Wintergarden	X			X

#### 4.4 Types of solutions to implement on ground

The ground-based solutions are defined and categorized considering the categories described in section 4.2 and the synergies of the climate-related challenges in section 3.

As part of UGI, nature based solutions can be used in ground surfaces as recreational areas, such as pocket gardens, in public or private spaces, as linear elements along the streets, such as infiltration strips or tree lines. Some green spaces can be created for a specific function, such as wetlands or rain gardens, but they can be designed as multifunctional elements, creating spaces for socialisation. Urban greenery provides several functions to the urban areas: they create shade, contribute to temperature regulation through evapotranspiration, improve air quality, reduce greenhouse gases emissions and reduce runoff. Moreover, they provide social benefits contributing to health and wellbeing of the users and improve urban biodiversity. Water solutions are divided between water surfaces, evaporative techniques and water devices. Water surfaces are natural water bodies (e.g. lakes, rivers) and artificial ones (e.g. fountains, artificial lakes). Evaporative techniques are mainly used to improve microclimate conditions, as through spraying and water curtains they improve outdoor thermal comfort. In addition, water devices, such as water storage systems, contribute to the management of the water cycle. Blue infrastructure solutions contribute to improving human thermal comfort through evapotranspiration and sustainable stormwater management. Moreover, as for green elements, water solutions also provide social benefits. The surface solutions using nature-based solutions to manage the water cycle are commonly referred as Sustainable Urban Drainage Systems (SUDS). They have been receiving more attention as, besides contributing to the water management objectives, they have benefits in carbon sequestration, urban cooling, human health and wellbeing (Charlesworth 2010).

BT such as cool materials as they generally include light colour layers applied on asphalt can be used to cover open spaces. Although solar reflectance reduces surface temperature, it can cause uncomfortable thermal conditions or glare issues. Pervious surfaces are widely used to contribute to the reduction of surface temperature through evaporation and to the reduction of water runoff. Moreover, by contributing to the mitigation of UHI, cool solutions potentially reduce directly and indirectly greenhouse emissions.

ES can be applied to open spaces, for example through the installation of PV pavements and roads. Moreover, urban furniture, such as acoustic barriers of the roads, street lighting or bus shelters can include photovoltaic technologies. The deployment of renewable energy systems in the cities is one of the key strategies to meet carbon neutrality.

Type of surface	Category	Solutions	Climate-related challenge addressed			
			ES	TR	SWM	HW
Open spaces	BT	Pervious pavements	X	X	X	
	BT	Cool pavements	X	X		
	UGI	Pocket gardens		X	X	X
	UGI	Bioretention areas		X	X	X
	UGI	Phytodepuration		X	X	

# **SOLUTIONS ROOF**







A green roof is a roof of a building partially or completely covered by vegetation. It includes several layers: vegetation, growing medium, filter layer, drainage layer, protection membrane, waterproof membrane, insulation, vapour barrier, a layer with a slope of 2% to drain the excessive rainwater and the slab. They can be classified as intensive green roof characterised by a wide variety of plants (shrubs, bushes and small trees) and a greater load on the roof structure; extensive green roof characterised by limited plants variety (hardy, drought tolerant, succulents, herbs or grasses), less total weight and the limited access, usually just for maintenance.

## Challenges

## Objectives

## Performances



Energy sustainability



Energy demand



Carbon impact



Energy produced from RES



Energy from RES on site



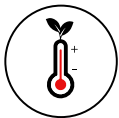
Low carbon material use



Greening



Energy efficiency



Temperature regulation



Local microclimate



UHI



Temperature surface/air



Outdoor thermal comfort



Shadow effect



Water management



Run off mitigation



Water scarcity



Water quality



Water retention



Water storage and reuse



Water treatment



Health and wellbeing



Comfort and life quality



Urban space quality



Green space



Space for socialization



Air quality



Walkability

## Other benefits



Indoor thermal comfort



Biodiversity



Noise pollution



Lifespan



Food production



Thermal insulation

## Regulations & Standards

UNI 11235

## Strategies



## Scale of application



## Space usage

Monofunctional  
Multifunctional

## S.D.G.

P 13.2 S 11.0  
P 13.3 S 15.3

## Disadvantages

Extra maintenance  
Extra weight load

# Energy consumption

# Temperature regulation



## Greening

The green roof system can decrease the carbon footprint through green roof layers, therefore can increase the energy saving. With appropriate plant and soil layers, different extensive green roofs could improve the carbon sequestration rate from 4.77 kg C eq. m<sup>-2</sup>yr<sup>-1</sup> to 7.11 kg C eq. m<sup>-2</sup> yr<sup>-1</sup>. *Case study:* the extensive green roof of the Berlin-Brandenburg Airport (Germany). The green roof is composed of different plants such as sedum floriferum Weihenstephaner Gold, Sedum album and Allium schoenoprasum. It was monitored for a full annual cycle. The results show that the green roof is a carbon sink on an annual basis with an uptake rate of - 313 g CO<sub>2</sub> m<sup>-2</sup>, equivalent to - 85 g C m<sup>-2</sup> [1].



## Temperature surface/air

One of the most important effects created by a green roof is the reduction of the surface temperature and the attenuation of temperature fluctuations, due to the plant shading, insulation guaranteed by the thickness of the substrate and evapotranspiration that depends on the foliage's size.

*Case study:* the green roof of the Regional Council building located in Ancona (Italy, cfa zone). A comparison between green roof and conventional roof has been conducted. The results show that for the green roof the heat flux is considerably reduced. The external surface temperature in July changes from 30.10 °C to 24.99 °C (under foliage) and in August, it changes from 31.72 °C (reference roof) to 24.89°C (under foliage) [3].



## Energy efficiency

The green roof system can indirectly reduce the building's energy consumption. Several studies show that all green roofs are more energy efficient than black roofs in all climates. Considering just the cfb zone, extensive green roofs can reach 84% of energy efficiency in an insulated roof, while they reach 100% with no insulation in the cooling season. During the heating season, they reach just 8% when the roof is insulated. For semi-intensive green roofs, the energy efficiency is just 7-8% either in the heating and cooling season and with an insulated roof. Finally, with an intensive green roof, the energy efficiency reaches 6-10% both in the heating and cooling season and with an insulated roof [2].



## Outdoor thermal comfort

Several studies show that green roofs can highly improve the outdoor thermal comfort by reducing the albedo and increasing shadow effect and evapotranspiration. In addition, some other parameters such as the orientation, the wind speed, the humidity and solar radiation should be considered.

*Case study:* the requalification of the district of Turin (Italy) with the use of green-roof technologies. The results show that the OTC evaluated using air temperature increases with the presence of plants. The increase of 15% in green areas implies a decrease in land-surface temperature (LST) of 2.7 °C. Finally, there is a significant relationship between LST and the building coverage ratio (BCR) of 34%, and a negative correlation between LST and NDVI (- 43%) [4].



## Shadow effect

The presence of foliage creates a shadow on the soil, which reduces the incident solar irradiation, therefore decreasing temperature and heat gain. The size of leaves is significant: benefits increase as the leaves increase.

*Case study:* green roof of the Regional Council building located in Ancona (Italy, cfa zone). A comparison between the green roof and the conventional roof has been conducted. It demonstrates the benefits of foliage in summertime. The results show that the monthly average of global horizontal radiation in July is 252.76 W/m<sup>2</sup>, while the radiation in the green roof is 38.29 W/m<sup>2</sup>. The values are positive also in August, in which the monthly average of global horizontal radiation is 281.08 W/m<sup>2</sup> and 29.87 W/m<sup>2</sup> in the green roof [3].

## References

- [1] J. Heusinger and S. Weber, *Extensive green roof CO<sub>2</sub> exchange and its seasonal variation quantified by eddy covariance measurements*, Science of The Total Environment 607–608 (31 December 2017) 623-632, <https://doi.org/10.1016/j.scitotenv.2017.07.052>
- [2] M. Manso, I. Teotónio, C. Matos Silva and C. Oliveira Cruz, *Green roof and green walls benefits and costs: a review of quantitative evidence*, Renewable and Sustainable Energy Reviews Volume 135 (January 2021) 110111, <https://doi.org/10.1016/j.rser.2020.110111>
- [3] R. Fioretti, A. Palla, L. G. Lanza and P. Principi, *Green roof energy and water related performance in the Mediterranean climate*, Building and Environment 45 Issue 8 (August 2010) 1890-1904, <https://doi.org/10.1016/j.buildenv.2010.03.001>
- [4] G. Mutani and V. Todeschi, *The Effects of Green Roofs on Outdoor Thermal Comfort*, Urban Heat Island Mitigation and Energy Savings, Atmosphere 2020, 11(2), 123; <https://doi.org/10.3390/atmos11020123>
- [5] C. A. Lepczyk, M. F. J. Aronson, K. L. Evans, M. A. Goddard, S. B. Lerman and J. S. MacIvor, *Biodiversity in the City: Fundamental Questions for Understanding the Ecology of Urban Green Spaces for Biodiversity Conservation*, BioScience 67 - Issue 9 (September 2017) Pages 799–807, <https://doi.org/10.1093/biosci/bix079>

# Water management



## Water retention

Green roofs can contribute to the reduction of stormwater runoff due to their capacity to retain water. The benefit of stormwater management depends on the roof age, slope, substrate thickness, composition, pore volume and degree of saturation, plant selection and type of drainage layer. According to several studies, extensive green roofs reduce, stormwater runoff at least 33% and a maximum by 81% (57% average). Concerning intensive green roofs, the average stormwater runoff retention is 79%, which represents a 22% higher than the water retention capacity of extensive green roofs. To the difference depends on the substrate depth [2].



## Water storage and reuse

The greywater can be collected by the drainage layer of the green roof and can be stored in a tank linked to the secondary pipeline. This pipeline is connected to a deposit with filtering water and a pump bringing water to upper levels. This process is necessary, because the greywater could contain concentration of nutrients, solid particles, microbes, organic and inorganic pollutants.

Local greywater recycling can contribute to save 9%-46% water of the household and could be used for many domestic uses such as for bathrooms, showers, laundries, washbasins and irrigation [2].



## Water treatment

According to several studies, green roofs improves the quality of water using their capacity to reduce the amount of dust, pollutants and nutrients that would be sent to the sewer system and the receiving stream. The green roof can retain up to 92% of Cb, 97% Cu, 99% Pb, and 96% Zn. In addition, green roofs retain nutrients with an average retention of 80% NO<sub>3</sub> and 68% PO<sub>4</sub> [2].

# Health and wellbeing



## Green space

Some studies show that urban green spaces, including green roofs, promote mental and physical health, providing psychological relaxation and stress alleviation. Health and wellbeing benefits derives from simply viewing a green space, even if not accessible [1].

It's shown that green roofs could be used for increasing urban green space in cities and promoting landscape connectivity. In addition, they have been recognized by ecologists as opportunities to contribute to urban wildlife. Parameters such as the size, height, and design contribute to the types and numbers of species frequenting green roofs. The height could be more restrictive; for example, any taxa able to reach the top of a building could have difficulty getting down, or sometimes taller buildings experience increased exposure to wind and solar radiation, further limiting their value as habitat [5].



## Space for socialization

Several studies show that the green roofs attract people and try to connect each other for urban agriculture. People can use green roofs to produce different vegetables and make the society self-resilient for food production. In addition, the results also indicated that with proper selection of vegetable types except pepper plants and proper management, extensive green roof can be helpful for food production [6].



## Quality of air

It's shown that green roofs can reduce the high levels of air pollution produced by many human activities, which are harmful to human health.

Several studies show that the extensive green roof, compared to a conventional roof, could have a higher average removal capacity of O<sub>3</sub> (1,96 g/m<sup>2</sup>/year about 20%), PM<sub>10</sub> (1,47 g/m<sup>2</sup>/year about 79%) and NO<sub>2</sub> (1,03 g/m<sup>2</sup>/year about 29%), but also for SO<sub>2</sub> (0,41 g/m<sup>2</sup>/year about 37%) and CO<sub>2</sub> (0,41 g/m<sup>2</sup>/year) [2].





# Green roof: best practice

## Project name

"Antonio Brancati"  
Middle School - School, college, University

## Climate zone

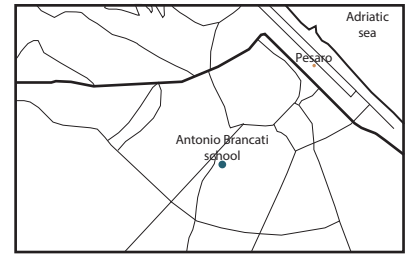
Csb - Coastal Mediterranean,  
Mild with cool, dry summer.

## Construction year

2018

## Location

Pesaro, Marche, Italy



— River  
— Highway  
— Roads

## Integrated system

Solar photovoltaic panels

## Certification

LEED Platinum

## Health & Comfort

The indoor comfort is guaranteed by the mechanical filtered ventilation climate system that allows the air exchange of 5 volumes per hour; some thermal sensors that control and regulate the temperature and the several tests (made) enhance the acoustic comfort.

## Energy consumption

Heating: 15.54 kWh/m<sup>2</sup>/year;  
Hot water: 0.89 kWh/m<sup>2</sup>/year;  
Cooling: 9.57 kWh/m<sup>2</sup>/year;  
Ventilation: 18.84 kWh/m<sup>2</sup>/year;  
Lighting: 15.58 kWh/m<sup>2</sup>/year;  
Lift: 0.25 kWh/m<sup>2</sup>/year  
Renewable energy production: 57,00 %



## GHG Cradle to Grave

579,70 KgCO<sub>2</sub> /m<sup>2</sup>

## Building quality

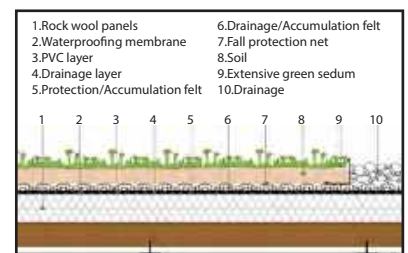
Building flexibility  
Comfort (visual, thermal, acoustic)



## How it works

Green roofs can be built with several materials and combinations of different technologies. Typically, the layers that characterize and define the performances of the roof are: plants, substrate and drainage/storage layer.

The order of the layers should guarantee that the drainage/storage layer collects the water from stormwater and from the plants without affecting the structure. In addition, all the layers improve thermal insulation, solar absorption control and accumulation/release of moisture.



## Description

In 2017, the city of Pesaro started the project of reuse of an old military site replacing three old army barracks built in 1950 with a new middle-school. The municipality launched a pilot project with the aim of improving energy efficiency, sustainability, responsibility, circular economy and other social considerations. The project focuses on the optimisation of circularity, the usage of sustainable building material and technologies, saving raw materials, product lifecycle, waste management, adaptability, durability, water efficiency, the creation of the best indoor environmental conditions for the students and teachers. The building structure is made by a reinforced concrete and timber structure for the roof, to reduce the environmental impact. In addition, this example of mainstreaming circular practices is harmonious within the context and creates a friendly new space for all the citizens, due to the tone-in-tone colours of the facade and the green roof. The green roof has Mediterranean plants with low water need to moderate the impact of high temperatures, capture storm water, abate pollution and act as carbon sinks.

Source: <https://www.construction21.org/case-studies/h/antonio-brancati-middle-school.html>, | Photo credit: -

A cool roof is characterised by a coating with high solar reflectance and high thermal emittance. Cool roofs are a solution to reduce the absorption of solar radiation, minimizing the temperature of external surfaces and heat loads caused by solar irradiation. These properties contribute to avoid overheating in buildings and urban areas and to disperse energy by irradiation, as well as to maintain low temperatures inside the building.



## Challenges

## Objectives

## Performances



Energy sustainability



Energy demand



Carbon impact



Energy produced from RES



Energy from RES on site



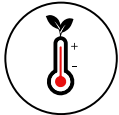
Low carbon material use



Greening



Energy efficiency



Temperature regulation



Local microclimate



UHI



Temperature surface/air



Outdoor thermal comfort



Shadow effect



Water management



Run off mitigation



Water scarcity



Water quality



Water retention



Water storage and reuse



Water treatment



Health and wellbeing



Comfort and life quality



Urban space quality



Green space



Space for socialization



Air quality



Walkability

## Other benefits



Indoor thermal comfort



Lifespan



Cooling costs



Easy to repair



Flexibility



Weather protection

## Regulations & Standards

UNI EN ISO 13786, UNI 10375 and UNI 11442

## Strategies



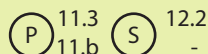
## Scale of application



## Space usage

Monofunctional  
Multifunctional

## S.D.G.



## Disadvantages

Limited application  
Susceptible to mold

# Energy consumption

# Temperature regulation



## Low carbon material use

A cool roof can highly reduce the carbon footprint in poorly insulated roofs in locations with high solar radiation and high ambient temperatures throughout the year.

*Case study:* a retrofit of a single storey building in Palermo (Italy, Csa zone). It is composed of a living room, a kitchen, a study and three bedrooms, with a total floor area of 100m<sup>2</sup>. The cool paint adopted for the roof is a waterborne liquid with 0.84 initial solar reflectance, 0.90 thermal emittance and initial solar reflectance index of 106. The paint is made by polymer, solvent, filler, titanium dioxide pigment, zinc dioxide additive and plasticizer. The simulation results show that the CO<sub>2</sub> emissions factor from electricity is 0.4109 kgCO<sub>2</sub>/m<sup>2</sup>/year and the CO<sub>2</sub> emissions saving is 0.96 kgCO<sub>2</sub>/m<sup>2</sup>/year. The LCA method, highlights that the production of polymer and pigment lifecycle phases are the main responsible for carbon impact [1].



## Temperature surface/air

Cool roofs can contribute to alleviating overheating/UHI in contexts with high solar radiation. To optimise the building performance, some parameters should be considered, such as albedo values between 0.6 - 0.7, air change rate of 2ACH, climate zone, orientation.

*Case study:* Open office area and three office rooms located on the top floor of a four-storey building in Brunel University (London, UK). The roof is composed of 0.15m thick concrete slab with 0.04 m of insulation layer, a thin layer of asphalt and a layer of cool material. The offices have a central heating system and a natural ventilation system. The results show that the cool roof can reduce the surface temperature of 2°C in the middle of the day, and it can reduce the air temperature with an average of 2-3°C in the middle of the day. By increasing the insulation layer, the cooling potential decreases because of the reduction of heat transfer [3].



## Energy efficiency

Several studies show that cool roofs considerably contribute to the reduction of energy demand for cooling and peak power requirements. The efficiency of this solution depends on climate zone, orientation, and the albedo value.

*Case study:* the municipality building of Acharnes in Greece (Csa zone). The municipality seat was built in 1998 and contains offices and the department itself in several floors. It is covered by grey cool tiles with an emissivity factor equal to 0.89. The building has oil fired boilers for heating, while heat pumps are used for cooling. As expected, the results show that the total annual energy saving for cooling and heating is 20.1 MWh (about 8.9%), while the total annual energy saving for cooling only is 22.2 MWh (about 17%) [2].



## Outdoor thermal comfort

The performance of cool roofs depends on the use of the building and the insulation adopted: if the insulation is thicker, the performance is reduced.

*Case study:* part of a four-storey building in the Saint Elio district in Poitiers (France). The terrace roof is made of steel cladding, a layer of mineral wool, a layer of asphalt and a double layer elastomeric self-protection. The results show a significant reduction by more than 10°C of outdoor surface temperature. It's shown that the cool roof has a strong impact on high temperatures due to the insulation layer. It means that during summertime, the cool roof guarantees a reduction of the heat island effect that allows to improve the thermal comfort outdoors [4].

## References

- [1] E. Shittu, V. Stojceska, P. Gratton, M. Kolokotroni, *Environmental impact of cool roof paint: case-study of house retrofit in two hot islands*, Energy and Buildings 217 (15 June 2020) 110007, <https://doi.org/10.1016/j.enbuild.2020.110007>
- [2] D.-D. Kolokotsa, G. Giannariakis, K. Gobakis, G. Giannarakis, A. Synnefa and M. Santamouris, *Cool roofs and cool pavements application in Acharnes, Greece*, Sustainable Cities and Society 37 (February 2018) 466-474, <https://doi.org/10.1016/j.scs.2017.11.035>
- [3] M. Kolokotroni, B. L. Gowreesunker and R. Giridharan, *Cool roof technology in London: An experimental and modelling study*, Energy and Buildings 67 (December 2013) 658-667, <https://doi.org/10.1016/j.enbuild.2011.07.011>
- [4] E. Bozonnet, M. Doya and F. Allard, *Cool roofs impact on building thermal response: A French case study*, Energy and building 43 – issue 11 (November 2011) 3006-3012, <https://doi.org/10.1016/j.enbuild.2011.07.017>



# Cool roof: best practice

## Project name

La Tuxa - Residential Building

## Climate zone

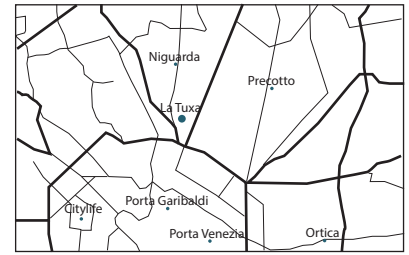
Cfb - Subtropical highland climate

## Construction year

2012

## Location

Milan, Italy



## Integrated system

Solar thermal panels  
Sunshade

## Certification

Klimahouse Gold  
Cened A+

## Health & Comfort

Quality of user's life and urban environment are improved by high energy efficiency solutions and by the cool roof preventing overheating.

## Primary energy

8,00 kWh/m<sup>2</sup>/year



## Sustainability

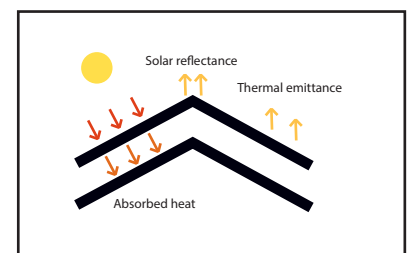
The building is characterised by rock wool external coat, mechanical ventilation system, low temperature radiant panels, the production of DHW by solar panels (more than 50%), and a rainwater recovery system used to irrigate the condominium outdoor garden and feed the toilet cisterns. All these elements make the building more sustainable. In addition, the cradle-to-grave approach shows a carbon emission of 13,00 KgCO<sub>2</sub>/m<sup>2</sup>.



## How it works

Cool materials should follow the specific features described by the ASTM E 1980 norm. It defines the solar reflectance index (SRI) as the capability of a surface to not overheat. It considers the solar radiation and the emissivity, expressed in percentage. If the surface cover is white the solar radiation equals 0.8, the emissivity equals 0.9 and the SRI is 100%; if the coverage surface is black the solar radiation is 0.05, the emissivity is 0.9 and the SRI is 0%.

The ideal coverage has solar radiation higher than 0.8, emissivity higher than 0.9, consequently the SRI is higher than 100%.



## Description

La Tuxa is located in Milan, between the so-called "Isola" and "Garibaldi" neighbourhood, it is one of the first Italian examples of residential buildings having almost zero consumption. It was designed following the purposes of energy saving, energy efficiency, environmental sustainability and indoor thermal comfort. It is composed of six floors with a total of eleven medium-size apartments. The structure is made of reinforced concrete covered by the external coat. The windows and the doors are made of wood-aluminium with the transmittance value equal to 0.8 W/m<sup>2</sup>K. In addition, some other solutions were adopted to achieve high energy efficiency such as summer shading design with a system of external slats (raffstore), controlled mechanical ventilation with the 88% of heat recovery, and cool roof. The cool roof is made of a white bituminous membrane reflective layer called Derbibrite Nt produced by Derbigum. Its 100% Solar Reflectance Index (SRI) guaranteed LEED credits for the reduction of the urban heat island effect.

Source: <https://www.construction21.org/case-studies/it/residential-building-la-tuxa.html>, [http://s3.amazonaws.com/europaconcorsi/project\\_documents/3469191/RIVISTA\\_PROGETTO\\_ENERGIA\\_76\\_-\\_SETTEMBRE\\_2012.pdf](http://s3.amazonaws.com/europaconcorsi/project_documents/3469191/RIVISTA_PROGETTO_ENERGIA_76_-_SETTEMBRE_2012.pdf), | Photo credit: -

# Ventilated roof



The ventilated roof systems are two slabs delimiting a duct through which air flows. This air gap/air flow reduces the heat transfer across the roof into the building. Ventilated roofs can be either passive, with stack effect driving the air flow, or active, with fan induced ventilation. In addition, the air flow can be laminar or turbulent depending on the size of the duct. The typical stratigraphy of a ventilated roof is composed of roof covering, air gap, insulation, waterproof sheath, and slab. If the system works properly the heat load is reduced by 30% and the users benefit of improved indoor comfort and of significant energy savings.

## Challenges



Energy sustainability



Temperature regulation



Water management



Health and wellbeing

## Objectives



Energy demand



Carbon impact



Energy produced from RES



Energy from RES on site



Local microclimate



UHI



Run off mitigation



Water scarcity



Water quality



Water retention



Water storage and reuse



Water treatment



Comfort and life quality



Urban space quality



Green space



Space for socialization



Air quality



Walkability

## Other benefits



Indoor thermal comfort



Air pollution



Cooling costs



Cooling effect



Const temperature



Mold - condensation

## Regulations & Standards

UNI 9460, UNI 8178 and UNI 8627

## Strategies



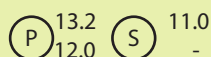
## Scale of application



## Space usage

Monofunctional  
Multifunctional

## S.D.G.



## Disadvantages

Reduction of acoustic indoor comfort  
Reduction of height cause



# Energy consumption



## Low carbon material use

The ventilated roof is a good solution to reduce the carbon footprint and to save energy. Some parameters that influence the performances are the thickness of air gap, the used materials and the climate zone.

*Case study:* a detached single floor house located in Catalonia (Spain). It is characterised by rectangular geometry, ground floor area of 100m<sup>2</sup> with standard accessibility to the construction site. The more common typologies of roofs have been analysed, but the focus is on the ventilated roof. It is composed of slab with 3% of slope, mineral wool insulation layer, bitumen membrane with polyester felt reinforcement, cement mortar regularisation layer, and external ceramic flooring tiles pavement. Adopting the LCA method, the results show that, the CO<sub>2</sub> emitted by a ventilated roof is equal to 86.61 CO<sub>2</sub>/m<sup>2</sup>.

This value is lower compared to some other solutions such as green roof (143 -145 CO<sub>2</sub>/m<sup>2</sup>), grey roof (127-130 CO<sub>2</sub>/m<sup>2</sup>) [1].

Another interesting case [3].

## Energy efficiency

Several studies show the ventilated roof is one of the most effective strategies to reduce energy consumption.

*Case study:* the building "Bent to the Sun" in The District of Tomorrow (TDoT) located on the European Science and Business Park Avantis in Heerlen/Aachen (in between the Netherlands and Germany). The BIPV roof includes 24PV modules, which are placed in 4 segments of 6 modules each. Each segment has a different air gap or hasn't any air gap. The natural ventilation duct adopted is of 13cm with an inclination of 12.5cm. The results show that in the segment chosen, the annual energy performance is 1216 kWh in the non-ventilated situation and 1249 kWh for the ventilated. Comparing the two results, it's notable that the PV performance has a difference of 2.7% on a yearly basis on the same location [2].



## References

- [1] M. J. Carretero Ayuso and J. García Sanz-Calcedo, *Comparison between building roof construction system based on the LCA*, Pontificia Universidad Católica de Chile. Escuela de Construcción Civil 2018, <http://hdl.handle.net/10662/10462>
- [2] M. J. Ritzen, Z. A. E. P. Vroon, R. Rovers and C. P. W. Geurts, *Comparative performance assessment of a non-ventilated and ventilated BIPV rooftop configurations in the Netherlands*, Solar Energy Volume 146 (April 2017) Pages 389-400, <https://doi.org/10.1016/j.solener.2017.02.042>
- [3] L. A. Molas Gazquez, F. Fernández Hernández and J. M. Cejudo López, *A Comparison of Traditional and Contemporary Social Houses in Catamarca (Argentina). Comfort Conditions and Life Cycle Assessment*, Sustainable Cities and Society Volume 82 (July 2022) 103891, <https://doi.org/10.1016/j.scs.2022.103891>



# Ventilated roof: best practice

## Project name

La casa del sole -  
Terraced Individual housing

## Construction year

2012

## Integrated system

Solar photovoltaic panels  
Solar thermal panels

## Health & Comfort

The use of low temperature floor heating and the South-South/West exposure of windows to get warm in winter and cold in summer, greatly improve the quality of users' life.

## Sustainability

The installation of 9m<sup>2</sup> of vacuum solar panels on the roof provides 90% of the ACS and 18% of the heating; the photovoltaic installation makes the dwelling self-sufficient, and more sustainable. In addition, the surplus of electricity produced at peak time constitutes a hub of electricity production.

## How it works

The potential of this system is the natural air cavity that separates the roof covering from the underlying insulation layers. It allows the activation of "upward convective motions" which subtract most of the heat/main? loads that would be transmitted to the other layers. This system guarantees moisture release without compromising the thermal insulation capacity of the roof. There are many different types of ventilated roof, such as: insulated-ventilated roof with double air cavity, insulated-ventilated roof with ventilation of protective undercoat, and insulated-ventilated roof on non-habitable attic with ventilation of the attic environment.

## Description

The residence Casotto - Goffo, known as "casa del sole", received a total renovation of the plants and of 90% of the structural parts. The compound is divided into two units: the first one is the house organised only on the ground floor; the second one is the apartment composed of three floors. Specifically, to improve the residence's performance, solar and PV panels were installed on the roof, a new masonry was built, the wooden ventilated roof was completely refurbished with an exposure to the south 30°. The ventilated roof is characterised by a galvanised sheet, air gap, wood fiber insulation panels, supporting structure in fir wood and bitumen membranes. At the end of recovering, the house was tested with thermographic tests and blower test and proving that its energy class changed from 260 kWh/m<sup>2</sup> to 39 kWh/m<sup>2</sup>.

## Climate zone

Csa - Hot - summer Mediterranean climate

## Location

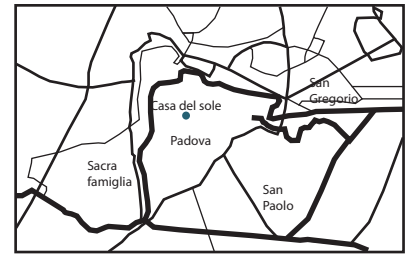
Padua, Veneto, Italy

## Certification

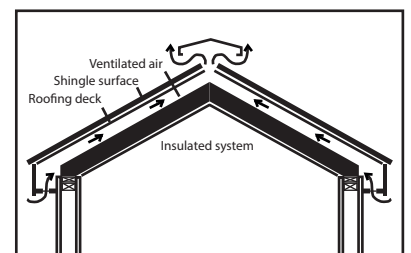
Class B

## Energy consumption

39,00 kWh/m<sup>2</sup>/year  
Renewable energy production: 60,00%



— River  
— Highway  
— Roads



A solar collector absorbs solar irradiation energy and converts it into thermal energy. The heat is transferred by its working fluid (air, oil or water) to the solar applications. Usually, the heat is used to either provide domestic hot water/heating, or to charge a thermal energy storage tank from which the heat can be drawn for later use. According to the position of storage, the system can be based on natural circulation that uses gravity force or forced circulation that needs some other devices to work properly. New technologies allow the solar thermal panels to be used in several applications and to increase energy efficiency.



## Challenges



Energy sustainability



Temperature regulation



Water management



Health and wellbeing

Other benefits

## Objectives



Energy demand



Carbon impact



Energy produced from RES



Energy from RES on site



Local microclimate



UHI



Run off mitigation



Water scarcity



Water quality



Comfort and life quality



Urban space quality



Integration



Lifespan



Storage



Easy to repair



Flexibility



Weather protection

## Performances



Low carbon material use



Greening



Energy efficiency



Temperature surface/air



Outdoor thermal comfort



Shadow effect



Water retention



Water storage and reuse



Water treatment



Green space



Space for socialization



Air quality



Walkability

## Regulations & Standards

UNI EN 12977, UNI 12975 and ISO 9806



Space usage

Monofunctional  
Multifunctional

## Strategies



S.D.G.

P 13.2 S 7.1  
12.0 11.0

## Scale of application



Building



Neighborhood



City



Disadvantages

High land-use  
Weather-dependent

# Energy consumption



## Energy from RES on site

Solar thermal panels can contribute to reach the European energy targets for 2030 and 2050.

*Case study:* it has been shown that an installation of 1200 m<sup>2</sup> of solar thermal in Milan can produce 836 MWh<sub>th</sub> of thermal energy. It's a significant result compared to other Italian cities, such as Naples or Rome. The reason of the better efficiency is related to the use of district heating [1].



## Low carbon material use

The carbon emission of solar thermal panel can be evaluated through cradle-to-grave LCA analysis and can provide different results according to the materials used and the local climate.

*Case study:* LCA comparison of unglazed panels (composed by a strip of polypropylene, 313 mm in width and variable in length) and glazed panels (consists of an external case in aluminium which contains two sheets of rockwool insulation, a sheet of absorber in copper and a serpentine pipe in copper alloy). The results show that the GWP is 1670.92kg CO<sub>2</sub>-eq for the glazed panels and 105.06 kg CO<sub>2</sub>-eq for the unglazed panels. The panels were tested in three different locations (Rome, Madrid and Munich) with traditional and electric boilers, to evaluate the influence of local climate [2].



## Energy efficiency

Several studies show that the solar thermal panels strongly reduce the energy consumption for DHW production. Some parameters influencing their efficiency are the orientation, building volume and geometry, and climate zone.

*Case study:* one-floor apartment located in Košice (Slovakia, Dfb zone), was adopted. It is characterised by floor area of 53 m<sup>2</sup>, heat load of 5 kW, and a specific annual energy supply equal to 163.585 W/m<sup>3</sup>. Twelve combinations of solar thermal panels and other devices were analysed with software and were compared with real cases. The results show that, using the software simulation, the energy demand for DHW is always 2040.65 kWh/year. Conversely, in real-time, this value is 725-792 kWh/ year. Specifically, the best value for DHW energy supply was from a wood-fired boiler installation with 725.17 kWh/year [3].

## References

- [1] B. Nastasi and U. Di Matteo, *Solar energy technologies in Sustainable Energy Action Plans of Italian big cities*, Energy Procedia 101 (2016) 1064 – 1071, <https://doi.org/10.1016/j.egypro.2016.11.136>
- [2] G. Comodi, M. Bevilacqua, F. Caresana, C. Paciarotti, L. Pelagalli and P. Venella, *Life cycle assessment and energy-CO<sub>2</sub>-economic payback analyses of renewable domestic hot water systems with unglazed and glazed solar thermal panels*, Applied Energy 164 (15 February 2016) 944-955, <https://doi.org/10.1016/j.apenergy.2015.08.036>
- [3] J. Košičan, M. A. Pardo Picazo, S. Vilčeková and D. Košičanová, *Life Cycle Assessment and Economic Energy Efficiency of a Solar Thermal Installation in a Family House*, Sustainability 221, 13(4), 2305, <https://doi.org/10.3390/su13042305>



# Solar thermal panels: best practice

## Project name

Casa Borghesan - Corti -  
Terraced Individual housing

## Construction year

2009

## Integrated system

Solar photovoltaic

## Health & Comfort

The installation of Controlled Mechanical Ventilation and Heat Recovery, combined the external thermal coating allow the building to be more comfortable for the users.

## Sustainability

Sustainability was a key aspect of the project. All materials of the original artefact have been recovered and reused. In addition, the recycled materials were combined with new ones, such as wood fiber and thermal plaster to protect and insulate the building.

GHG before use: 128,00 KgCO<sub>2</sub>/m<sup>2</sup>

## How it works

Solar thermal panels can be divided into: not concentrating collectors - in which the collector area intercepting solar radiation is the same as the absorber area (i.e. flat-plate collector); and concentrating collectors in which the area intercepting solar radiation is greater, sometimes hundreds of times greater, than the absorber area (i.e. parabolic trough collector).

Typically, the system is composed by the collectors that capture the sun's energy by heating a fluid contained within reinforced glass pipes. The pump and controller ensure that the transfer fluid circulates between the collectors and the water cylinder efficiently.

## Description

The original building was built in 1927 and shows all the typical features of the Liberty style. Due to the high discomfort in wintertime and the over-consumption for heating, the house needs interventions. A specific approach was developed to combine energy and structural retrofitting. For this purpose, the original structure of the roof was preserved and combined with the installation of controlled mechanical ventilation and heat recovery. In addition, PV panels and solar thermal panels were applied to satisfy the electricity demand and the hot water demand. To improve water management and to avoid moisture problems, an excavation perimeter was done. In addition, to ensure the isolation, a XPS panel of 12 cm was adopted for the underground level, a layer of wooden fiber for the front (without ornaments), and an inner layer of wooden fiber combined with thermal plaster was used for the floor.

## Climate zone

Cfa - Humid subtropical climate

## Location

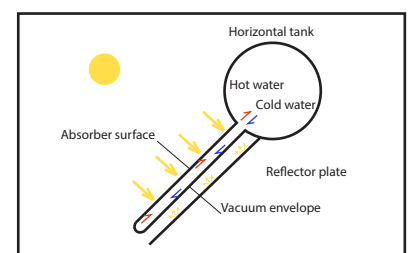
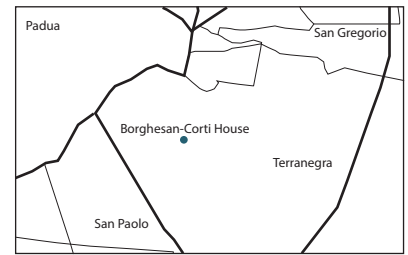
Padua, Veneto, Italy

## Certification

Class B+

## Primary energy

38.00 kWhpe/m<sup>2</sup>/year  
Renewable energy production: 65.49 %







# Yellow roof



The Photovoltaic (PV) system is made by a group of solar modules that work together to produce electricity connected to a structure with inverters, charge regulators and batteries. PV solar technology can be used as a standalone system or as a grid-connected installation. PV technology converts light into electricity directly using solar cells without gas emissions or noise. Most of them are made with silicon because they have the most efficiency ranges 12-17% and these can be monocrystalline or polycrystalline. Other kinds of PV cells are thin film cells made from very thin layers of photosensitive materials placed on backing such as glass, steel or plastic.

## Challenges

## Objectives

## Performances



Energy sustainability



Energy demand



Carbon impact



Energy produced from RES



Energy from RES on site



Low carbon material use



Greening



Energy efficiency



Temperature regulation



Local microclimate



UHI



Temperature surface/air



Outdoor thermal comfort



Shadow effect



Water management



Run off mitigation



Water scarcity



Water quality



Water retention



Water storage and reuse



Water treatment



Health and wellbeing



Comfort and life quality



Urban space quality



Green space



Space for socialization



Air quality



Walkability

## Other benefits



Easy to repair



Lifespan



Flexibility



Cooling costs



Weather protection



UV rays

## Regulations & Standards

IEE, IEC and D.L. n.17 of 01/03/2022

## Strategies



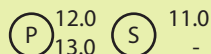
## Scale of application



## Space usage

Monofunctional  
Multifunctional

## S.D.G.



## Disadvantages

Weather dependent  
Lack of a system of energy storage

# Energy consumption



## Energy from RES on site

Photovoltaic panels could produce enough energy to make the building self-sufficient if installed in zones with high solar radiance and with suitable inclination angle.

*Case study:* elementary school of Serres located in Serres (Macedonia, cfa zone). It is characterised by an insulated envelope, half openings with double glazing, half with single glazing and a metallic frame with no insulation. The building with these features presents a primary energy consumption of 250.7kWh/m<sup>2</sup> and energy performance ranked as E. To improve the building performance small photovoltaic (PV) stations with 2,1 kWp power were installed on the roofs. The results show that PVs can reduce the 8.23% energy consumption [1].

passive measures, such as external thermal insulation, new windows and doors with double glazing and metallic insulated frame, shading overhangs above south orientation openings, and the installation of electricity and thermal energy production from RES. The results show that, after the application of the passive solutions, the percentage of electricity consumption reduction was 77,65% with a PV installed power equal to 5,0 kWp. In addition, the primary energy consumption was reduced to 92.07 kWh/m<sup>2</sup> and the new energy performance is ranked as B [1].



## Low carbon material use

Life cycle assessment (LCA) method can be applied to evaluate the energy consumption in the manufacturing and construction of PV electricity generation plants, CO<sub>2</sub> emissions caused by PV power generation and the energy pay-back time (EPBT). Several studies show that the accumulated primary energy consumption for the construction of the photovoltaic power plants ranges from 13,000 to 21,000 kWh/kWp. The life cycle CO<sub>2</sub> emissions is 3.360 kg-CO<sub>2</sub>/kWp for the amorphous technology. The emissions also depends on the type of PV panel: (i.e. mono-crystalline or poly-crystalline). In order to define a general value of?, two examples have been considered. Muneer et al. (ANNO) show that the GHG emission of a mono-crystalline PV in the UK is 44.0 g-CO<sub>2</sub>/kWh. Battisti and Corrado (ANNO) demonstrate that, the GHG emissions for a poly-crystalline panel in Italy is 26,4 g-CO<sub>2</sub>/kWh [2].



## Energy efficiency

Several studies show that photovoltaic panels strongly reduce energy consumption, if they are installed in some conditions such as in hot climates, with the correct orientation and inclination angle.

*Case study:* elementary school located in Polykastro (Thessaloniki, Greece, cfa zone). It is characterised by no envelope insulation and not insulated openings with single glazing and metallic frame. The building with these features presents a primary energy consumption of 628.5 kWh/m<sup>2</sup> and energy performance ranked as G. The building was retrofitted adopting some

## References

- [1] Dimitris Al. Katsaprakakis, George Zidianakis , *Upgrading Energy Efficiency For School Buildings In Greece*, Procedia Environmental Sciences 38 (2017) 248 – 55, <https://doi.org/10.1016/j.proenv.2017.03.067>
- [2] A.F. Sherwani, J.A. Usmani, Varun, *Life cycle assessment of solar PV based electricity generation systems: A review*, Renewable and Sustainable Energy Reviews 14 - Issue 1(January 2010) 540-544, <https://doi.org/10.1016/j.rser.2009.08.003>



# Yellow roof: best practice

## Project name

New four classrooms (extension) - school, college, university

## Construction year

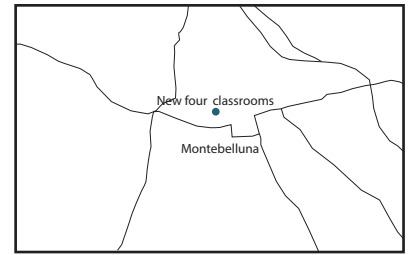
2007

## Climate zone

Cfa - Humid subtropical climate

## Location

Montebelluna, Veneto, Italy



— River  
— Highway  
— Roads

## Integrated system

Thermal insulation coating  
Venetian blinds

## Certification

Class A

## Health & Comfort

The simple control system for air quality and the South-South/West exposure of windows, greatly improve the quality of users' life.

## Energy consumption

20,00 kWhpe/m<sup>2</sup>/year  
Renewable energy production: 115,00%



## Sustainability

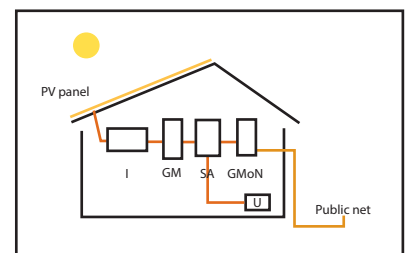
To reduce energy consumptions, some strategies were adopted such as the XPS insulation, the air-to-air heat pumps, and solar panels. In addition, the direct sunlight gain provides about 46% of the heat demand. All these strategies make the building more sustainable and almost self-sufficient.



## How it works

The PV cells of panels located on the roof capture the energy from the sunlight. This energy creates electrical charges that allows electricity to flow which converts the direct current (DV) into alternating current (AC). The flow continues its path from the invert to the generator that counts the quantity of electricity generated and is the amount directed to the devices and plugs. The users consume the generated electricity and, if the energy produced is more than requested, it can be introduced in the energy grid and sold to the energy provider. Alternatively, it could be stored in batteries.

(I: inverter, GM: generator meter, SA: solar accumulator, GMoN: generator meter of net, U: users)



## Description

The city of Montebelluna requested to build an extension of 4 new classrooms of a secondary school reduce energy consumptions. The structure of the building is composed of reinforced concrete columns and Predalles floor plates; in addition, all window frames are made of wood with safety glass, cavity filled with argon gas and low emission surfaces. The project focused on structural reinforcement, the provision of improved indoor comfort using renewable energies, energy efficiency and low energy consumptions with low budget solutions. The great advantage of this building are the switchboards that can monitor produced electricity from PV panels, as well as electrical consumptions operating heat pumps, fans for ventilation and artificial lighting. The solar panels placed on the roof can provide the electricity for the lighting, ventilation (air exchange). The production of electricity is equivalent to 5400 kWh/year, while its consumption amounts to 4785 kWh/year. The building consumes very little energy, and it produces a surplus of 600 kWh of electricity per year.

Source: <https://www.construction21.org/case-studies/it/nuova-costruzione-4-aule-scuola-media-ampliamento-en.html>, | Photo credit: -

**SOLUTIONS  
FACADES**







# Thermal insulation

Thermal insulation is a flexible technology that can be collocated on the outer or inner wall, for new construction or for retrofitting interventions. It can be a cavity wall insulation or an interlayer of the wall. Insulation products are classified into three groups - mineral fibre, cellular plastic, and plant/animal derived. The first category includes rock, slag and glass wool. The second category are oil-derived - rigid polyurethane, phenolic, expanded/ extruded polystyrene - available as loose fill, rigid sheets, and foam. The last category includes cellulose fibre, sheep wool, cotton, and flax, available as fibre, batts, or compressed board.



## Challenges

## Objectives

## Performances



Energy sustainability



Energy demand



Carbon impact



Energy produced from RES



Energy from RES on site



Low carbon material use



Greening



Energy efficiency



Temperature regulation



Local microclimate



UHI



Temperature surface/air



Outdoor thermal comfort



Shadow effect



Water management



Run off mitigation



Water scarcity



Water quality



Water retention



Water storage and reuse



Water treatment



Health and wellbeing



Comfort and life quality



Urban space quality



Green space



Space for socialization



Air quality



Walkability

## Other benefits



Indoor thermal comfort



Flexibility



Noise pollution



Cooling costs



Fire resistant



Low-cost solution

## Regulations & Standards

ISO 6781, ISO 9869-1 and ISO 9869-2

## Strategies



## Scale of application



## Space usage

Monofunctional  
Multifunctional

## S.D.G.



## Disadvantages

Mold and condensation problems  
Exposed to atmospheric agents

# Energy consumption

---



## **Low carbon material use**

Thermal insulation reduces energy consumption, consequently limiting the buildings' environmental impact. In addition, the comparison between other building materials and thermal insulation shows that the environmental effect of thermal insulation is small.

*Case study:* fifteen insulating materials different in thickness, density and thermal conductivity have been tested using an exterior building envelope, in Ljubljana (Slovenia). The goal of the study was to compare the environmental impact of selected materials using the 'cradle-to-gate' LCA method. The results show that for an envelope of 400m<sup>2</sup> and a thermal conductivity of 0,20 W/m<sup>2</sup>K, wood-based, rock-based insulations, and cellulose recycled cause minimal environmental impact ranging on average from 0.062 to 1.156 kg of CO<sub>2</sub>-eq. In contrast, thermal insulations with high carbon footprint, such as VIP and XPS, cause the higher environmental impact of 16.6 and 13.4 t CO<sub>2</sub>-eq, respectively [1].



## **Energy efficiency**

Studies show that the environmental effects of thermal insulation materials in comparison with other building materials are small, while the energy savings they produce are significantly high.

*Case study:* a virtual model of a two-storey residential single-house, located near the city of L'Aquila (Italy). The model has the same buildings' characteristics: north-south orientation, geometry, internal gains, reinforced concrete with EPS insulation as bearing structure, and prefabricated wood-cement blocks with high thermal performance for the structure. The model has been studied through simulations with EnergyPlus. The results show that the best combination, made by air boiler and air handling unit, has an energy consumption of 974.7 kWh/y, resulting in 67% of energy saved. The worst-case scenario is the use of an air-to-water heat pump that consumes 4401.4 kWh/y [2].

## **References**

- [1] R. Kunič, *Carbon footprint of thermal insulation materials in building envelopes*, Energy Efficiency 10 (17 June 2017) pages 1511–1528, <https://doi.org/10.1007/s12053-017-9536-1>
- [2] T. Rubeis, I. Nardi, D. Ambrosini, D. Paoletti, *Is a self-sufficient building energy efficient? Lesson learned from a case study in Mediterranean climate*, Applied Energy 218 (15 May 2018) Pages 131–145, <https://doi.org/10.1016/j.apenergy.2018.02.166>



# Thermal insulation: best practice

## Project name

Passivhaus Marlegno -  
Terraced Individual housing

## Climate zone

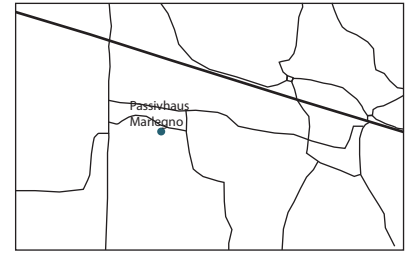
Csa - Hot-summer Mediterranean climate

## Construction year

2015

## Location

Bolgare, Lombardy, Italy



— River  
— Highway  
— Roads

## Integrated system

Solar photovoltaic

## Primary energy

98,00 kWhpe/m<sup>2</sup>/year

## Health & Comfort

Energy efficiency, use of solar shade and thermal insulation guarantee indoor thermal comfort, improving the quality of users' life.

## Environmental Quality

- indoor air quality and health
- comfort (visual, thermal, acoustics)
- renewable energies
- building end of life management
- energy efficiency



## Sustainability

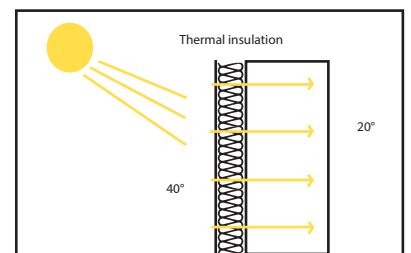
The entire house is made of sustainable materials. The innovative construction system called TAVEGO allows to assemble wooden walls and wooden beams without the use of adhesives. This methodology takes full advantage of the ecological characteristics of a natural material such as wood, reducing carbon emissions and making the interior spaces healthier.



## How it works

Thermal insulation is a method to prevent thermal energy transfer from one space to another. Typically, the heat flow has three different mechanisms of transmission - conduction, convection, radiation- and it changes from warmer to cooler areas until there is no longer a temperature difference. The most common insulation materials work by slowing conductive and convective heat flow.

The thermal resistance (R-value) represents the resistance of the material to the heat flow. This value depends on the type of thickness, density, temperature, moisture of the layer. The commercial material with the highest thermal resistance is the expanded polystyrene (EPS).



## Description

Passivhaus Marlegno is a single two-floor villa completely integrated into the urban surroundings. It was designed following the standards of the Passivhaus Institut: high thermal insulation, air tightness, reduction of thermal bridges, high-performance windows, solar gains and VMC with heat recovery. The house has load bearing walls and wooden boards floor assembled without glue. The buildings' stratigraphy has a U value of 0.083 W/m<sup>2</sup>k guaranteed by a natural stone wool coat 30 cm thick; the openings are carefully designed to acquire an appropriate solar gain in winter and adequately shielded with sunshade to prevent overheating in summer. In addition, an integrated home automation system controls the management of consumption, heating and cooling, lighting and solar shading.



# Green wall



Living walls can support several varieties of plant species growing along the vertical surface reaching higher areas and adapting to different types of buildings. Their systems are composed of pre-vegetated panels, vertical modules or planted blankets that are fixed vertically to a structural wall or frame. There are two main types of living walls: Continuous system and Modular system. The continuous system is composed of synthetic fabric, growing media, plants, and they are supported on a framework. The modular system is composed of containers which hold the growing media, regular irrigation system and fertilisation system that use gravity.

## Challenges

## Objectives

## Performances



Energy sustainability



Energy demand



Carbon impact



Energy produced from RES



Energy from RES on site



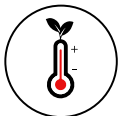
Low carbon material use



Greening



Energy efficiency



Temperature regulation



Local microclimate



UHI



Temperature surface/air



Outdoor thermal comfort



Shadow effect



Water management



Run off mitigation



Water scarcity



Water quality



Water retention



Water storage and reuse



Water treatment



Health and wellbeing



Comfort and life quality



Urban space quality



Green space



Space for socialization



Air quality



Walkability

Other benefits



Indoor thermal comfort



Biodiversity



Lifespan



Food production



Noise pollution



Artistic expression

## Regulations & Standards

UNI 11235

## Strategies



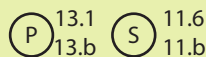
## Scale of application



## Space usage

Monofunctional  
Multifunctional

## S.D.G.



## Disadvantages

Not easy to repair  
Not lightweight system

# Energy consumption

# Temperature regulation

## Greening



Several studies show that the green wall offers multiple benefits, one of the most important is its ability to capture the CO<sub>2</sub> emissions. This ability depends on the location, orientation, typology and thickness of the layers that compose the wall. *Case study:* 98m<sup>2</sup> of green wall on a south-oriented building facade in Siena (Italy, cfa zone). The herbaceous species selected for the CO<sub>2</sub> sequestration simulation are six species of perennial herbaceous plants - *Sedum spurium*, *Salvia nemorosa*, *Rosmarinus officinalis*, *Geranium sanguineum*, *Carex brunnea* and *Fatsia japonica* - and one perennial grass - *Zoysia matrella* -. The dynamic model's results show that the entire wall can retain a carbon dioxide flow of 13.41-97.03 kg CO<sub>2</sub>eq per year. Specifically, the *S. Nemorosa* was responsible for the highest CO<sub>2</sub> sequestration in terms of long - lasting accumulation, equal to 1640.27 kgCO<sub>2</sub>eq. Generally, the simulations demonstrate that the best species in terms of CO<sub>2</sub> accumulation is *C. Brunnea*, while the best species in terms of highest CO<sub>2</sub> retained is *R. officinalis* [1].

## Energy efficiency



Several studies show how important the presence of the green walls is in terms of energy performances. This ability depends on the orientation, the geometry, the typology of the wall as the thickness and the kind of layers. *Case study:* a 3m x 3m house with the green wall (GW) on the south and west facades located in Puigverd de Lleida (Portugal, csa zone). The element is characterised by a square pot made up of 3mm recycled polyethylene, 8cm of coconut fibre as substrate, 24 small plants and 4 micro irrigation tubes. The aim is to compare the energy performances of a GW, green façade and an uncovered façade. The results show that during the summer period, the GW can save energy in a range of 20%-60%, conversely the GF can save energy in a range of 5%-35%. During the wintertime, the energy saved by GW is in between 3% and 6%, conversely the GF can save at maximum 2% of energy [2].

## Temperature surface/air



Green walls can considerably reduce the UHI effect which leads to an increase of air temperature in urban areas up to 2°C–5°C compared to less populated areas. This result is influenced by the orientation of the wall, geometry, and typology and thickness of layers.

*Case study:* a south-west oriented 3 m x 3 m green wall prototype is installed in the headquarters of the IUAV University of Venice (Italy). The system is characterised by the presence of an aluminium structure, a PVC panel installed on it, and a vertical turf grass. The results show that when comparing bare wall and green wall the temperature difference during the day reaches values up to 16°C, during the night, the temperature difference is about 6 °C. In addition, during cloudy days the surface temperature of the bare wall is higher than the green wall of 1 °C [3].

## Outdoor thermal comfort



Several studies show that due to density of foliage, the obstacles, the geometry, the orientation, typology of plants, and thickness of layers, green walls could improve the outdoor thermal comfort. *Case study:* the central business district (CBD) in Melbourne (Australia). Just scenario D and E characterised by 50% of green walls and 100% of green walls were considered. The results show that in scenarios E/D the reduction of air temperature ranged between 6-10°C, and the relative humidity ranged between 0-1.8%. In addition, the PET index is between 33.2 and 59.0, it shows that the green walls could slightly improve the outdoor thermal comfort [4].

## Shadow effect



The foliage is characterised by leaf area index (LAI) that is the key parameter to define the foliar density and consequently the thermal behaviour of VGS. It depends on the typology of plants, the orientation building and the climate zone.

*Case study:* a steel modular existing double-skin greening system located near to Lleida (Spain, bsk zone). It is composed of *Glycine* climber plants and its light transmission factor has the value in between 0.04 in July to 0.37 in April, during the season with the foliage fully developed. In addition, the transmission capacity of four different plant species is well adapted such as *Ivy* Honeysuckle, *Virginia creeper* and *Clematis*. The results show that the light transmission factor values of 0.15 for *Virginia creeper*, 0.18 for *Honeysuckle*, 0.14 for *Clematis* and 0.20 for *Ivy* plants [5].

## References

- [1] M. Marchi, R. M. Pulselli, N. Marchettini, F. M. Pulselli and S. Bastianoni, *Carbon dioxide sequestration model of a vertical greenery system*, *Ecological Modelling* 306 (24 June 2015) 46-56, <https://doi.org/10.1016/j.ecolmodel.2014.08.013>
- [2] J. Coma, G. Pérez, A. Gracia, S. Burés, M. Urrestarazu and L. F. Cabeza, *Vertical greenery systems for energy savings in buildings: A comparative study between green walls and green facades*, *Building and Environment* Volume 111 (January 2017) Pages 228-237, <https://doi.org/10.1016/j.buildenv.2016.11.014>
- [3] U. Mazzali F. Peron, P. Romagnoni, R. M. Pulselli and S. Bastianoni, *Experimental investigation on the energy performance of Living Walls in a temperate climate*, *Building and Environment* 64 (June 2013) 57-66, <https://doi.org/10.1016/j.buildenv.2013.03.005>
- [4] F. Balany, N. Muttil, S. Muthukumar, M. Sing Wong and A. W. M. Ng, *Studying the effect of the Effect of Blue-Green Infrastructure on microclimate and human thermal comfort in Melbourne's CBD*, *Sustainability* 2022,14(15), 9057, <https://doi.org/10.3390/su14159057>
- [5] G. Pérez, J. Coma, S. Sol, and L. F. Cabeza, *Green facade for energy savings in buildings: The influence of leaf area index and facade orientation on the shadow effect*, *Applied Energy* 187 (February 2017) 424-437, <https://doi.org/10.1016/j.apenergy.2016.11.055>



# Water management



## Water retention

Several studies show that the green vertical system can greatly benefit the urban environment by delaying water peak flows. This capability depends on typology and thickness of system, orientation and material used.

*Case study:* GVs with expanded cork in the climatic chamber. Two tests were performed – fully confined tests and partially confined tests – using expanded cork agglomerates different in height, thickness, and density. The experiment was conducted with three kinds of density – standard, medium and high – and with four flushes hypnotised. The results of the second test show that in the first flush the medium density specimens retain 20.4 kg/m<sup>3</sup>, but only 8.62 kg/m<sup>3</sup> in the following flushes. Generally, thinner specimens have smaller retention capacity than the thicker specimens [6].



## Water treatment

Several studies show that greening systems provide many benefits such as greywater treatment. This property depends on the typology and thickness of layers, the typology of plants, and the orientation of the facade.

*Case study:* a living wall located in Mannheim (Germany). The south-oriented facade is characterised by a substrate container of 25 cm composed of polyethylene (PE) plate and a mixture of expanded clay aggregate (66.6%) and biochar (33.3%), and air gap of 5 cm. The foliage has the albedo equal to 0.3, with a transmittance index equal to 0.2 and the area density equal to 6 m<sup>2</sup>/m. The simulation results show the greywater flow rate in the substrate is 75 L/d [7].

# Health and wellbeing



## Green space

Several studies show that people benefit from the vertical greening system without consciously using it.

*Case study:* Quirónsalud Sagrado Corazón Hospital (QSCH) is located in Sevilla (Spain, csa zone). In 2012, a living wall of 40 m<sup>2</sup>, a felt system with pockets in which the plant root balls are inserted, was installed on the external facade facing the hall. Twenty-six pre-coded questions divided in 4 categories (personal data, attitude towards green elements, Self-Reported Psychological Well-Being Gai and 'contingent valuation') and the options for responses have been submitted to 555 people. From the interviews the following results have been obtained. When viewing the LW, 82% of participants feel happy and calm, 87.7% of participants feel more positive emotions or reactions, around 60% of them feel serenity or welfare and 31% happiness. Finally, 30% of the respondents showed negative (mainly allergies) or no reactions, and only 3.8% expressed indifference or negative feelings in all the items. 'Calm' and 'happiness' were the answers preferred, followed by 'pleasant' and 'stimulating' [8].



## Space for socialization

The green wall are not directly used to create a space for socialization, because they are not accessible. However, the green wall, associated with some other urban furniture, can create a comfortable space where people can meet. This space can use the advantages related to the green wall and at the same time can promote the interactions.

*Case study:* Breathe O<sub>2</sub> living art installation was made in the USA in 2014. The installation is made up of more than 3500 annual, perennials and tropical plants with a large leaf-pattern that represent Michigan native trees. The installation is 22 feet tall and 150 feet large [9].



## Quality of air

The green wall is one of the best solutions that could improve air quality. Some plants, depending on their form and dimension, can capture the air pollutant and consume CO<sub>2</sub> to develop their vital function, and introduce O<sub>2</sub> in the air.

*Case study:* According to the review of Manso et al. (2021), green walls can also contribute to air pollutants removal as much as 11.7%–40% of NO<sub>2</sub>, and 42%–60% of PM<sub>10</sub>, 40% O<sub>3</sub>, 3.5% SO<sub>2</sub>, 1.34% CO<sub>2</sub> and also 1.34% PM<sub>2.5</sub> [10].

[6] A. Cortês, J. Almeida, J. Brito and A. Tadeu, *Water retention and drainage capability of expanded cork agglomerate boards intended for application in green vertical systems*, Construction and Building Materials 224 (November 2019) Pages 439-446,

<https://doi.org/10.1016/j.conbuildmat.2019.07.030>

[7] H. Alsaad, M. Hartmann and C. Voelker, *The effect of a living wall system designed for greywater treatment on the hygrothermal performance of the facade*, Energy and Buildings 255 (15 January 2022) 111711, <https://doi.org/10.1016/j.enbuild.2021.111711>

[8] L. Pérez-Urrestarazu, A. Blasco-Romero, R. Fernández-Cañero, *Media and social impact valuation of a living wall: The case study of the Sagrado Corazon hospital in Seville (Spain)*, Urban Forestry & Urban Greening 24 (May 2017) 141-148,

<https://doi.org/10.1016/j.ufug.2017.04.002>

[10] M. Manso, I. Teotónio, C. Matos, S. Carlos and O. Cruz, *Green roof and green wall benefits and costs: A review of the quantitative evidence*, Renewable and Sustainable Energy Reviews 35 (January 2021) 110111, <https://doi.org/10.1016/j.rser.2020.110111>

[9] WEBSITE - LiveWall, <https://livewall.com/benefits/#artex>, Access 24/10/2022



# Green wall: best practice

## Project name

Fiordaliso shopping center -  
Commercial building

## Climate zone

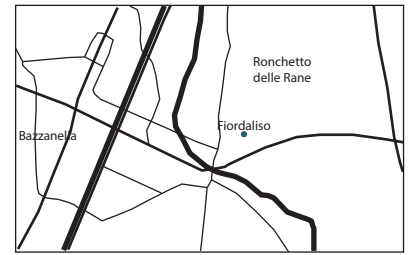
Cfa - Humid subtropical climate

## Construction year

2012

## Location

(Rozzano) Milan, Lombardy, Italy



## Integrated system

Cool roof

## Certification

BREEAM-In-Use given by BRE

## Health & Comfort

The building guarantees thermal, visual, and acoustic comfort. In addition, some "green cleaning" interventions have been adopted, to improve the accessibility for people with disability.

## Energy consumption

-



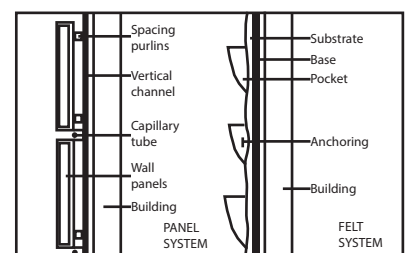
## Sustainability

In this project, the cool roof and the green wall avoid the absorbance of solar radiation, limiting summer overheating and winter heat losses. In addition, the green elements, make the building more sustainable.



## How it works

The green wall Living walls differ from green facades in being able to support vegetation that is rooted in an attached substrate to the wall itself, rather than being rooted at the base of the wall. The typical green wall is composed by a waterproof membrane against the facade to protect it, framework structure, layers of synthetic fabric with pockets filled with growing media and plants. Basically, each kind of medium-small plants compatible with local climate could be used. Another important aspect is the irrigation system. The most efficient plant is the internal drip green wall irrigation watering system that recaptures and re-circulates water throughout the plants in the Green Wall. It pumps the water to the top and flows from plant to plant to the bottom, guaranteeing adequate quantity of water for all the walls. The green wall can have several configurations using different technologies such as panel system, felt system, modular system.



## Description

The green wall is an alternating combination of evergreen and flowering plants, which allows the viewer to follow the change of seasons consequently to see the chromatic metamorphosis, changing from bright green to white to intense red. With a surface of 1.262 square meters, the vertical garden is the largest living wall in the world. The wall is composed of 44.000 plants of 200 different species such as Festuca tenuifolia, Delosperma cooperi, Campanule, etc. The selection considered several factors such as the local climate, the wall integration in the surrounding green system, the resistance to the one-year test in the nursery, and the capability of the plants. The water retention capacity of the soil, can hold water up to ten times its weight, guaranteeing water supply even at high temperatures. Moreover, micro-droplets, bring considerable savings. In addition, the green wall protects the building from solar radiation in summer and avoids heat losses in winter, therefore has a strong impact on the energy balance. This element allows the reduction of CO<sub>2</sub> emissions, improvement of air quality, improvement of visual impact, and it works as a noise barrier.

Source: <https://una.city/> and <https://www.youinit.it/progetti/>, | Photo credit: -



# Green facade

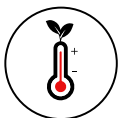


Green facades are a system in which climbing plants (one or two) or cascading groundcover growing up an existing vertical surface. Green facades are mainly rooted at the base of these structures, in the ground, in intermediate planters or even on rooftops. They can be anchored to existing walls or built as free-standing structures, usually cable and wire rope net system, metal mesh system and modular trellis panels. They are classified into two main categories: direct and indirect greening system. In addition, the indirect green facades function as “double skin facades”, creating an air gap between the building surface and the vegetation.

## Challenges



Energy sustainability



Temperature regulation



Water management



Health and wellbeing

Other benefits

## Objectives



Energy demand



Carbon impact



Energy produced from RES



Energy from RES on site



Local microclimate



UHI



Run off mitigation



Water scarcity



Water quality



Water retention



Comfort and life quality



Urban space quality



Green space



Indoor thermal comfort



Biodiversity



Cooling effect



Air pollution



Noise pollution



Carbon sequestration

## Performances



Low carbon material use



Greening



Energy efficiency



Temperature surface/air



Outdoor thermal comfort



Shadow effect



Water storage and reuse



Water treatment



Space for socialization



Air quality



Walkability

## Regulations & Standards

## Strategies

## Scale of application



Building



Neighborhood



City

## Space usage

Monofunctional  
Multifunctional

## S.D.G.

P 13.1 13.b S 11.6 11.b

## Disadvantages

More expensive  
More intensive maintenance

# Energy consumption

# Temperature regulation



## Low carbon material use

It's known that the green vertical systems play an important role in a sustainable urban environment, therefore the entire greening solution should be designed to pursue the sustainable aims.

*Case study:* the indirect green facade system with constructive un-vegetated technical solutions as PVC ( $GF_{PVC}$ ), nylon cables ( $GF_N$ ) and wood ( $GF_W$ ), were compared. The experimental data of the green facade prototype characterised by a steel frame and *Rhynchospermum Jasminoides* vegetation and located at the University of Bari, were collected. The results of the carbon footprint of the green facade prototype ( $GF_S$ ) show that only the  $GF_W$  has a low impact close to 20 kg CO<sub>2</sub> eq, followed by the  $GF_S$  with a GWP<sub>100</sub> value equal to 32 kg CO<sub>2</sub> eq. Conversely the  $GF_{PVC}$  has the highest environmental impact equal to 50 kg CO<sub>2</sub> eq [1].



## Greening

It's known that the green facade is less complex, in terms of components and systems, compared to a green wall. Proportionally, the environmental impact is reduced by about 5%.

*Case study:* three experimental cubicles characterised by three different facade - green facade, green wall and bare wall - located in Puigverd (Spain, csa), were considered. The aim is to compare the potential environmental impacts of the three cubicles, using the LCA method. The results obtained by the study of manufacturing, operational and maintenance stages show that the green facade impact is 616,17 kg CO<sub>2</sub> eq. That is lower than the green wall impact equals to 646,18 kg CO<sub>2</sub> eq [2].



## Energy efficiency

Several studies show that green facade could help buildings to save energy, their foliage could create the shadow effect that in summer protects from the solar radiation and in winter provides thermal insulation.

*Case study:* a Boston ivy double-screen green facade located in Puigverd de Lleida (Spain, csa zone) was adopted. The aim is to understand how the changing of the foliage can reduce the energy consumption during the year, according to different orientations. The results show that, during cooling periods, the energy saving reaches up to 54% reductions in early summer and 30% during late summer when the foliage is degraded. On the other hand, during autumn and winter, the green facade leads to a 5.4% increase in the daily energy consumption for heating [3].



## Temperature surface/air

Green facade can be used in passive design of buildings to reduce the UHI effect. In addition, this system could offer several benefits such as the reduction of solar absorbance and of the heat load and the improvement of thermal insulation.

*Case study:* two experimental green facades located in Valenzano (Bari, Italy, csa zone) were tested. The aim is to evaluate the thermal effect of the two facade characterised by two kinds of plants: *Pandorea jasminoides* and *Rhynchospermum jasminoides*. The results show that during the summertime, the external air temperature measured on the south oriented green facades is around 1-2° on cloudy days and around 7-8° on sunny days. During the wintertime, the temperature of the green wall is in a range of 1-2° higher. Lower than the respective temperatures of the uncovered wall up to 9.0 °C [4].



## Outdoor thermal comfort

Several studies show that a green facade could help to reduce the UHI effect and to improve the outdoor thermal comfort because of its low absorptivity and its thermal capacity.

*Case study:* green facade located in Madrid (Spain, Bsk zone), was adopted. The aim is to analyse the effects of these elements in the urban microclimate and to understand how the urban comfort could be improved. The results show that, adopting a green facade, the temperature decreases by 0.13°C, the wind speed decreases by 0.25 m/s and the relative humidity values generally can be increased during the summer and improve human comfort [5].



## Shadow effect

It's known that a well designed green vertical system can improve the indoor thermal comfort during the entire year. Naturally, the performance of the green facade depends on the orientation, the geometry, and the kind of vegetation.

*Case study:* four modular and south oriented trellises were prepared to accommodate a container garden in Puigverd de Lleida (Spain, Csa zone). The aim is to compare the growth of four different climbing - ivy, honeysuckle, virginia creeper and clematis -, as well as their ability to provide shadow. The results show that the plants best developed in height were ivy and honeysuckle, but they left some areas with lower density of foliage. For each plant the light transmission factor has been calculated for Ivy is 0.20, clematis 0.41, Honeysuckle 0.18 and Virginia creeper 0.15 [6].

## References

- [1] I. Blanco, G. Vox, E. Schettini, G. Russo, *Assessment of the environmental loads of green façades in buildings: a comparison with un-vegetated exterior walls*, Journal of Environmental Management Volume 294 (15 September 2021) 112927, <https://doi.org/10.1016/j.jenvman.2021.112927>
- [2] G. Pérez, M. Chafer, J. Coma, L. F. Cabeza, *A comparative LCA between green walls and green facades in the mediterrian continental climate*, Energy & Buildings 249 (2021) 111236, <https://doi.org/10.1016/j.enbuild.2021.111236>
- [3] G. Pérez, J. Coma, M. Chàfer, L. F. Cabeza, *Seasonal influence of leaf area index (LAI) on the energy performance of a green facade*, Building and Environment 207 – part B (January 2022) 108497, <https://doi.org/10.1016/j.buildenv.2021.108497>
- [4] G. Voxlleana, B. E. Schettini, *Green facades to control wall surface temperature in buildings*, Building and Environment 129 (1 February 2018) Pages 154-166, <https://doi.org/10.1016/j.buildenv.2017.12.002>
- [5] F. Olivieri, P. Vidal, R. Guerra, M. Chanampa, J. García, C. Bedoya, *Green Facades for Urban Comfort Improvement Implementation in a extreme Continental Mediterranean climate*, PLEA2012 - 28th Conference Perú 7-9 November 2012, <https://oa.upm.es/22812/>

# Water management



## Water retention

Several studies show that the green facades gave a strong water retention capability. This strength depends on different parameters such as the leaf area index, foliage profile, depth and typology of soil, evapotranspiration rate and drainage layer.

*Case study:* two vertical green facades were located on the south facing brick wall of a detached residential property in the UK. The first facade is fully foliated and the second one is predominantly twiggy, but both are about 3 m high, 0.5 m deep and 1.2 m wide, supported by wooden frames. The results show that, after 12 weeks of measurement and 27 events, the potential precipitation interception for the facades with distinct morphological features are different. For the fully-foliated facade the typical interception range is 54–94% and a delay of precipitation event of 30 min, conversely for the twiggy facade the interception range is 10–55% and the delay of precipitation event is about 15 min [7].



# Health and wellbeing

## Green space

Several studies show that the physical and visual direct contact with greenery can highly decrease stress, violent behaviour, and fear. On the other hand they can increase the resistance to illness, patience and enhance public spaces, and add identity to a building.

*Case study:* 24 photographs of four different houses with various types of vegetation were created and a questionnaire was designed and submitted to 188 people in the UK. The multiple-choice answers were divided in 4 groups as Preference, Beauty, Affective Quality and Restoration. The results show that the houses with vegetation were more preferred. The most rated was ivy, followed by meadow, with Sedum, turf and brown vegetation. The same experiment was submitted again in the South-East of England. The results confirmed the classification obtained in the first experiment [8].

## Quality of air

The usage of a vertical green façade could reduce the particulate matter capturing the air pollution and giving back oxygen. The main parameters that determine the amount of capturing are humidity, meteorological conditions, precipitation and the foliage density.

*Case study:* the experiment was carried out in Hanover (Germany). The aim is to determine the PM content on the leaf surface using the gravimetric method. The results show that in wintertime, the total amount of PM deposited on the leaves of *Hedera helix* varied between  $161 \pm 8 \mu\text{g cm}^{-2}$  and  $158 \pm 28 \mu\text{g cm}^{-2}$ . In addition, the comparison with other vegetation shows that *hedera helix* has the lowest capacity for  $\text{PM}_{10}$  capture that is equal to  $0.1613 \pm 0.0138 \text{ mg cm}^{-2}$ , and for  $\text{PM}_{2.5}$  capture that is equal to  $0.1557 \pm 0.0078 \text{ mg cm}^{-2}$ [9].



- [6] G. Pérez, L. Rincón, A. Vila, J. M. González, L. F. Cabeza, *Behaviour of green facades in Mediterranean Continental climate*, Energy Conversion and Management 52 – Issue 4 (April 2011) Pages 1861-1867, <https://doi.org/10.1016/j.enconman.2010.11.008>
- [7] A. Tiwary, K. Godsmark, J. Smethurst, *Field evaluation of precipitation interception potential of green facades*, Ecological Engineering 122 (15 October 2018) Pages 69-75, <https://doi.org/10.1016/j.ecoleng.2018.07.026>
- [8] E. V.White, B. Gatersleben, *Greenery on residential buildings: Does it affect preferences and perceptions of beauty?*, Journal of Environmental Psychology 31- Issue 1 (2011) 89-98, <https://doi.org/10.1016/j.jenvp.2010.11.002>
- [9] C. He, K. Qiu, A. Alahmad, R. Pott, *Particulate matter capturing capacity of roadside evergreen vegetation during the winter season*, Urban Forestry & Urban Greening 48 (February 2020) 126510, <https://doi.org/10.1016/j.ufug.2019.126510>





# Green facade: best practice

## Project name

Le Albere district – Residential,  
Commercial, educational buildings

## Climate zone

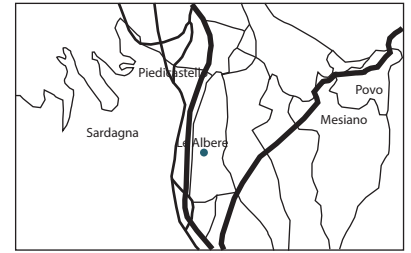
Cfb - Subtropical highland climate

## Construction year

2014

## Location

Trento, Trentino, Italy



## Integrated system

Solar PV  
Sunshade  
Geothermal plant

## Certification

Level B of CasaClima and LEED Gold

## Health & Comfort

The natural shade effect helps to prevent overheating in summer and improve the quality of users' life.

## Energy consumption

40-50 kWh/m<sup>2</sup>/year  
0,6 Megawatt/year

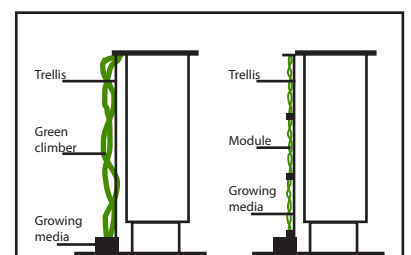


## Sustainability

In this project, the most commonly used material is the wood. This material combined with the usage of some other natural-based solutions such as the green facade or the passive systems as the sunshade, create an eco-friendly and sustainable district.

## How it works

They are classified into two main categories: direct and indirect greening systems. In the first system, common ivy is used due to the adhesive property that can allow the plants to be attached directly to the wall. In addition, the plant roots are either placed in the ground or in planter boxes. In the second system all types of plants could be used, due to the presence of the additional supporting structure systems. This component allows the plants to develop their growth along the wall. As in the first case, the rooting space is either placed in the ground or in planter boxes which may either be placed at the bottom of the facade or at multiple intervals along the wall. According to the height that they want to reach, vegetation and system are chosen. For example, Common ivy (*Hedera helix*) or three-leaved creepers (*Parthenocissus*) are used for self-bonders with a growing height up to 30 m. Using several types of system means creating different facades, specifically four types of facade vegetation can be discerned: Bonders, self-bonders using clinging roots.



## Description

Le Albere district is on a surface of 11 hectares, and it is composed of 300 passive apartments, 30.000 square meters of offices, shops, squares, roads, pedestrian, and bicycle paths. The district is bordered on the south by the library and to the north by the natural science Museum. The aim of the project is to develop an eco-friendly, sustainable and high-efficient space using innovative strategies as the green facade. This natural solution is made by a structure consisting of steel elements in tension on which two types of ivy climb (one evergreen and one deciduous leaf). These elements are delimited by the planters containing the roots at the base and by a handrail at the top. The entire system acts as a parapet located close to the large-glazed window. These parapets solve the aesthetic problems and energetic problems partially. In addition, each apartment is equipped with photovoltaic systems and coloured roller blinds that allow the improvement of indoor thermal comfort, energy saving and adequate privacy.

Source: M. Marcantoni and M. L. Dinacci, LE ALBERE: il quartiere green di Renzo Piano, IASA Edizioni 2011, Trento, | Photo credit: -



# Cool wall

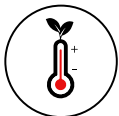


The cool facade refers to exterior walls that reflect the infra-red portion of the sun's rays, keeping the exterior surface cooler and allowing less heat to be transferred into the building interior. The albedo stemming from the use of either light-coloured paints or "cool colours," and high thermal emittance. The exteriors of many buildings are painted by a variety of lighter and darker colours that use reflective "cool" pigments, regardless of the underlying material used in construction, other types of siding, may be pre-painted or pigmented in the factory. In most cases they use paints, but in few other cases synthetic waterproofing membranes are used.

## Challenges



Energy sustainability



Temperature regulation



Water management



Health and wellbeing

Other benefits

## Objectives



Energy demand



Carbon impact



Energy produced from RES



Energy from RES on site



Low carbon material use



Greening



Energy efficiency



Local microclimate



UHI



Temperature surface/air



Outdoor thermal comfort



Shadow effect



Run off mitigation



Water scarcity



Water quality



Water retention



Water storage and reuse



Water treatment



Comfort and life quality



Urban space quality



Green space



Space for socialization



Air quality



Walkability



Indoor thermal comfort



Flexibility



Cooling costs



Lifespan



Weather protection

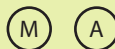


Easy to repair

## Regulations & Standards

ASHRAE 90.1 and ASHRAE 189.1

## Strategies



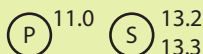
## Scale of application



## Space usage

Monofunctional  
Multifunctional

## S.D.G.



## Disadvantages

Inadequate for colder climates  
Get dirty easily

# Energy consumption

# Temperature regulation



## Low carbon material use

Increasing wall albedo contributes to energy saving and carbon footprint reduction. To implement this strategy, cool walls should be combined with wall geometry, wall orientation, and climate.

*Case study:* three different buildings - new, older (for 1980 buildings), and oldest (for pre -1980 buildings) - located in California (USA, different climate zones). The prototypes were simulated with wood-frame walls and attic roof and concrete foundation. The simulations for the single-family home, medium and large office building, and stand-alone retail store were conducted. The results show that the cool walls can reduce annual pollutant (CO<sub>2</sub>e, NO<sub>x</sub>, SO<sub>2</sub>) emissions by -1.5 -24% in single-family homes, 0.3-3.8% in medium office buildings, and 0.0-10% in stand-alone retail stores [1].



## Energy efficiency

Cool materials could improve the building energy performances and reduce cooling use up to 20%. The improvement depends on the climate zone and the insulation level.

*Case study:* the simulation is made on a 3-storey block located in three different cities Milan, Rome and Palermo (Italy, different climate zone). The building contains 6 apartments, each of them is characterised by a net floor area of 80.41 m<sup>2</sup>, windows area of 10.50 m<sup>2</sup>, internal height of 2.7 m and it is divided into two thermal zones: day and night. Two building envelope configurations were implemented: insulated and not insulated. The results show that the cooling savings is 1.5 kWh/m<sup>2</sup> for insulated buildings and 1.0 kWh/m<sup>2</sup> for the not insulated one, in Rome and Milan. In Palermo, cooling savings are around 2.0 kWh/m<sup>2</sup> for both configurations. For heating, the penalties are lower than 5% in Milan and Rome for both configurations, around 7%-9% in Palermo [2].



## Temperature surface/air

The application of innovative cool paintings on the external surface of walls combined with the right orientation, significantly reduces wall surface temperature.

*Case study:* a comparison between a fully instrumented test-room and a case scenario in Perugia (Italy). The test-room is characterised by an opening ratio of 0.41 due to the rectangular window in the South facade and a rectangular armoured door in the North facade. In addition, the cool painting among the facade consists of white non-organic painting, composed of potassium silicate and resin. The results show that the cool facade painting can reduce the external surface temperature up to 9.9 °C, 8.7 °C, 13.8 °C, and 11.4 °C for the South, North, East, and West wall, respectively [3].



## Outdoor thermal comfort

Increasing the albedo of walls, combined with other strategies such as urban canyon geometry, is a strategy to reduce the urban heat island effect.

*Case study:* a typical residential area with three storey terraced houses in London (UK). The area includes street canyons with different orientations and a width of 16 m, and buildings altitude 10 m. The aim is to investigate the multiple impacts of reflective materials on outdoor thermal comfort. The results show that increasing the facades reflectance reduces the Mean Radiant Temperature, and it improves the Physiological Equivalent Temperature up to 0.5 °C. Conversely, the reduction of the facade reflectance reduces the PET temperatures up to 1.6 °C, while the reduction in MRT is up to 3.3 °C. In case of low reflectance of the facade, the outdoor thermal comfort is improved [4].

## References

- [1] P. J. Rosado and R. Levinson, *Potential benefits of cool walls on residential and commercial buildings across California and the United States: Conserving energy, saving money, and reducing emission of greenhouse gases and air pollutants*, Energy and Buildings 199 (15 September 2019) Pages 588-607, <https://doi.org/10.1016/j.enbuild.2019.02.028>
- [2] M. Zinzi, *Characterisation and assessment of near infrared reflective paintings for building facade applications*, Energy and Buildings 114 (15 February 2016) Pages 206-213, <https://doi.org/10.1016/j.enbuild.2015.05.048>
- [3] A. L. Pisello, V. L. Castaldo, C. Piselli, C. Fabiani, F. Cotana, *Thermal performance of coupled cool roof and cool facade: Experimental monitoring and analytical optimization procedure*, Energy and Buildings 157 (15 December 2017) Pages 35-52, <https://doi.org/10.1016/j.enbuild.2017.04.054>
- [4] A. Salvati, M. Kolokotroni, A. Kotopouleas, R. Watkins, R. Giridharan, M. Nikolopoulou, *Impact of reflective materials on urban canyon albedo, outdoor and indoor microclimates*, Building and Environment 207-B (January 2022) 108459, <https://doi.org/10.1016/j.buildenv.2021.108459>



# Cool wall: best practice

## Project name

Residential isolated tower building

## Climate zone

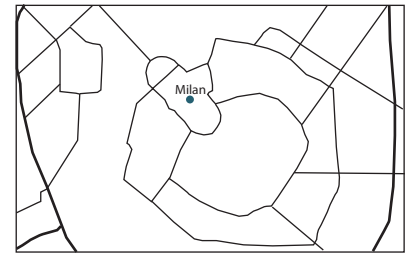
Cfa - Humid subtropical climate

## Construction year

2012 - 2016

## Location

Milan, Lombardy, Italy



## Integrated system

Thermal insulation

## Energy needs

11% non-retrofitted case  
5% retrofitted case

## Temperature surface

A white aged ETICS (insulation layer) can be 6 °C hotter than when new, considering a typical hot summer day in Milan.

With aging, for the non-insulated wall, the temperature surface changes from 32 °C to 38 °C, while for the wall with ETICS the variation is from 33 °C to 40 °C, implying an increase in the magnitude of thermal stress-strain cycles.

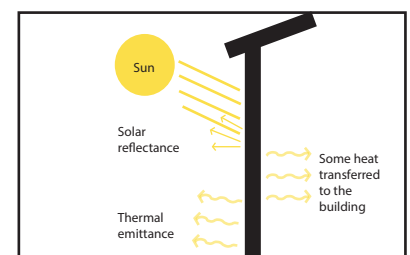
## Energy efficiency

Difference in cooling load of 0.16 kWh m<sup>-2</sup> y<sup>-1</sup> for the insulated case and 0.08 kWh m<sup>-2</sup> y<sup>-1</sup> for the uninsulated case. A small reduction of the initial heating need, of 4% and 2% for the non-retrofitted and retrofitted buildings, respectively.



## How it works

The wall is covered by a cool material that allows the building to not overheat. The cool material should have some specific features: in particular, the ASTM E 1980 norm defines the solar reflectance index (SRI) as the capability of a surface to not overheat. It considers the solar radiation and the emissivity and it is expressed in percentage. If the coverage surface is white the solar radiation equals 0.8, the emissivity equals 0.9 and the SRI is 100%; if the coverage surface is black the solar radiation is 0.05, the emissivity is 0.9 and the SRI is 0%. The best coverage has solar radiation higher than 0.8, emissivity higher than 0.9, consequently the SRI is higher than 100%. Compared to a ceiling that usually has a percentage of reflectance of 80% - 90%, the wall can reflect the solar radiation at maximum 60%.



## Description

The principle of a cool wall was adopted to a facade of building in Milan, from April 2012 to April 2016. The purpose is to evaluate the solar reflectance and thermal emittance before and after aging of two finish coating natural exposed. Two standard finish coats beige and white with  $\rho_s$  equal to 0.46 and 0.75 respectively, have been selected from the market. It's shown that the finish coat lost in average 0.02-0.03  $\rho_s$  with different according to the exposure north-south. After 48 months, the losses were 0.08 for the white finish coat and 0.20 for the beige one. To determine the impact of weathering and soiling of cool walls on the building hygrothermal and energy performance, a ten-storey isolated tower building has been chosen. This is characterised by 30m of height, and 20.3 m x 20.3 m in plan, with a total net floor area of 3307 m<sup>2</sup>. Two cases have been studied: non retrofitted case and retrofitted case with a insulation layer.



# Cool wall: best practice

## Project name

Palazzo Santander - offices building

## Climate zone

Cfb - Subtropical highland climate

## Construction year

2018

## Location

Turin, Piemonte, Italy



## Integrated system

Ventilation system,  
Internal thermal insulation,  
Geothermal probs.

## Certification

GBC Historic building

## Health & Comfort

The air conditioning system was verified by a questionnaire during the first year of employment, in order to improve the comfort quality of users.

## Energy efficiency

The building saves 24% of energy compared to the reference building and it uses 100% of renewable sources.

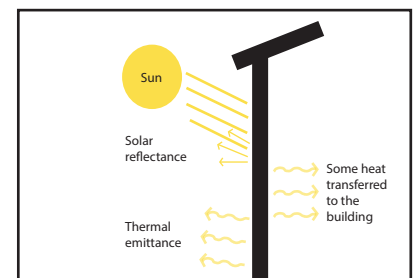


## Sustainability

The eco-friendly building is characterised by an internal green courtyard with cool pavements studied to reduce the UHI effect, a dual network connected to the rainwater collection to reduce the water needs. In addition, LED lighting and inner thermal coat were adopted, to enhance the visual and thermal comfort. Some precautions for environmental sustainability as the recycling of 100% of construction site waste and the usage of materials with EPD, were adopted.

## How it works

The wall is covered by a cool material that allows the building to not overheat. The cool material should have some specific features: in particular, the ASTM E 1980 norm defines the solar reflectance index (SRI) as the capability of a surface to not overheat. It considers the solar radiation and the emissivity and it is expressed in percentage. If the coverage surface is white the solar radiation equals 0.8, the emissivity equals 0.9 and the SRI is 100%; if the coverage surface is black the solar radiation is 0.05, the emissivity is 0.9 and the SRI is 0%. The best coverage has solar radiation higher than 0.8, emissivity higher than 0.9, consequently the SRI is higher than 100%. Compared to a ceiling that usually has a percentage of reflectance of 80% - 90%, the wall can reflect the solar radiation at maximum 60% .



## Description

The building is in the ex Isvor area, and it is the first Fiat production site since the early twentieth century. For his historical value, is protected by the superintendence of cultural heritage. The results of the historical value, energy and structural investigations represent the basis for the subsequent design. The building is composed of three floors and 600mq, and it can host around 500 people. The entire building is virtually connected vertically by a green element, while the relationship with the context is enhanced by the corner on the ground floor where the reception and the main entrance are located. The main feature is the light colour of the building that combined with all the internal strategies adopted, guarantee the high level of reflectance. This factor is extremely important in terms of heat gain loss and consequently it will be reflected on the energy consumption and indoor thermal comfort.





# Trombe wall



The Trombe walls are a type of technology derived by a combination of thermal mass and glazing elements to collect and store solar radiation. Trombe walls are made up of a material as bricks or concrete that are characterised by high thermal mass, usually coated with a dark colour paint to achieve higher solar absorptivity. In addition, an air cavity is necessary, which can be very narrow or large enough to be habitable, to allow air movement between the glazing and the wall. This system could be improved using double glazing with low-e coating or installing a solar thermal system on the effective emissivity surface.

## Challenges



Energy sustainability



Temperature regulation



Water management



Health and wellbeing

## Objectives



Energy demand



Carbon impact



Energy produced from RES



Energy from RES on site



Local microclimate



UHI



Run off mitigation



Water scarcity



Water quality



Comfort and life quality



Urban space quality



Indoor thermal comfort



Flexibility



Cooling effect



Noise pollution



Heat gain



Weather protection

## Performances



Low carbon material use



Greening



Energy efficiency



Temperature surface/air



Outdoor thermal comfort



Shadow effect



Water retention



Water storage and reuse



Water treatment



Green space



Space for socialization



Air quality



Walkability

## Regulations & Standards

-

## Strategies



## Scale of application



Building



Neighborhood



City



## Space usage

Monofunctional  
Multifunctional



## S.D.G.



13.0



-

-



## Disadvantages

Less natural daylight  
Weather dependent

# Energy consumption

---



## **Low carbon material use**

Several studies show that the traditional Trombe wall is made up of materials such as concrete and aluminium framing, characterised by a strong environmental impact that could be easily reduced using different materials and thickness.

*Case study:* a Trombe wall in a solar residential building prototype in Ancona (Italy, cfa zone). The Trombe wall system installed on the southern side, is made up of a 40 cm concrete with plaster, a single glazed window and external-aluminium frame. The aim is to calculate the carbon footprint using the LCA method. The results show that the Trombe wall has a carbon impact equal to 1562.90 kg CO<sub>2</sub> eq. in the pre-use phase, plus a 1061.40 kg CO<sub>2</sub> eq. contribution of use-phase, for a total of 2624.31 kg CO<sub>2</sub> eq. CO<sub>2</sub> emissions. The experiment shows that, by changing the material, the carbon footprint can be reduced up to a maximum equal to -1105.00 kg CO<sub>2</sub> eq. (-71%) for the pre-use phase, -576.00 kg CO<sub>2</sub> eq. (-54%) for the use phase and -1445.28 kg CO<sub>2</sub> eq. for the entire process [1].



## **Energy efficiency**

The Trombe wall improves energy efficiency, by capturing solar radiation and using it for space heating. The absorbance improves with adequate wall design, in terms of geometry, orientation, location and materials.

*Case study:* two single-family houses located in Lyon (France). The two houses are characterised by an average elevation of 240 m, ten rooms, and just one of them has the Trombe wall. A comparison between the building with the Trombe wall and the building without one, was done. The results show that the Trombe wall could guarantee primary operating energy savings up to 21%, and it could save more proportionally to the thicker core layer of clay brick that is able to accumulate more solar ray's heat [2].

## **References**

- [1] F. Stazi, A. Mastrucci, P. Munafò, *Life cycle assessment approach for the optimization of sustainable building envelopes: An application on solar wall systems*, Building and Environment 58 (December 2012) Pages 278-288, <https://doi.org/10.1016/j.buildenv.2012.08.003>
- [2] M. Bojić, K. Johannes, F. Kuznik, *Optimizing energy and environmental performance of passive Trombe wall*, Energy and Buildings 70 (February 2014) Pages 279-286, <https://doi.org/10.1016/j.enbuild.2013.11.062>



# Trombe Wall: best practice

## Project name

Residential two - storey family house

## Climate zone

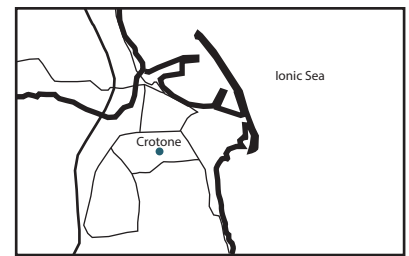
Csa - Hot-summer Mediterranean climate

## Construction year

2022

## Location

Crotone, Calabria, Italy



## Carbon emission

The system allows to save 185 kg of emitted CO<sub>2</sub>.

## Certification

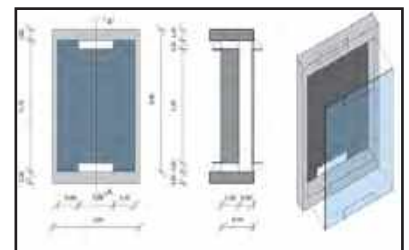
-

## Payback time

The investment costs can be recovered in less than 6 years, independently from the electric energy inflation rate, assuming an air-conditioning system driven by an air-air heat pump.

## Energy consumption

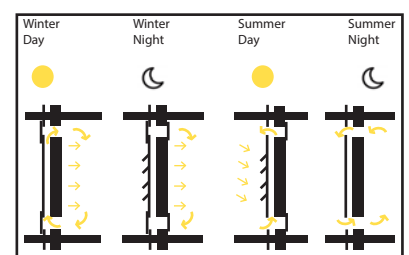
430 kWh (-10.5%) for heating  
316 kWh (-9.5%) for cooling



## How it works

Sunlight passes through the glass panel in front of the wall, then the air in the gap between the wall and the glass is heated through conduction. Finally, the air can pass through the top vent into the home, heating the house via convection. At the same time, cold air is drawn in through the bottom vent to be heated by the sun and rise up again. This creates a cycle of warm air flow.

Throughout the day, the wall will continuously absorb heat, then, at night when temperatures drop, it will release the heat absorbed by the concrete wall, providing a comfortably warm internal space overnight.



## Description

The residential two-storey family house is developed on two floors with an eight of 3 m each. The ground floor contains the hall, kitchen, living room, bathroom, and the second floor contains 3 bedrooms and two bathrooms, for a total floor area of 125 m<sup>2</sup>. The south-facing vertical walls are available for hosting Trombe Walls. It is composed of: externally, a double-pane system (with U<sub>g</sub> of 2.471 W/m<sup>2</sup>K and U<sub>w</sub> of 2.013 W/m<sup>2</sup>K) equipped with vents, and, internally, by the existing dark-coloured painted external wall. In addition, air vents guarantee thermo-circulation between the air gap and the indoor environment. The entire system has modular features for an easy installation. Simulations were carried out to determine the heating and cooling energy needs of the building and the achieved thermal performances, both in winter and summer.



# Glass with solar control



Solar control glass is an hi-product characterised by a special coating designed to reflect and filter the sun's rays, allowing natural daylight into the room, but without uncomfortable visual glare. The indoor space stays bright and much cooler than it would be in the case of normal glass. To render switchable solar control glazing, two types of materials are placed between two glass or plastic sheets. The first material is an electrochromic material and the second one is a thermotropic material such as hydrogels. Solar control is often specified for large-glazed areas, facades, conservatories, windows, skylights and roofs.

## Challenges



Energy sustainability



Temperature regulation



Water management



Health and wellbeing

Other benefits

## Objectives



Energy demand



Carbon impact



Energy produced from RES



Energy from RES on site



Local microclimate



UHI



Run off mitigation



Water scarcity



Water quality



Comfort and life quality



Urban space quality



Indoor thermal comfort



Glare



Cooling costs



Heat gain



Easy to repair



Daylight

## Performances



Low carbon material use



Greening



Energy efficiency



Temperature surface/air



Outdoor thermal comfort



Shadow effect



Water retention



Water storage and reuse



Water treatment



Green space



Space for socialization



Air quality



Walkability

## Regulations & Standards

EN 1096 and EN 17074



Space usage

Monofunctional  
Multifunctional

## Strategies



S.D.G.

P - S 11.0  
S 13.0

## Scale of application



Building



Neighborhood



City



Disadvantages

Overheating  
Not suitable in cool climates

# Energy consumption



## **Low carbon material use**

Several studies show that solar control film could be economically advantageous and could reduce the carbon footprint to 2 times less than a new window.

*Case study:* a typical office located in Lisbon (Portugal, Csb zone). It is characterised by a floor area of 17 400 m<sup>2</sup>, a glazing area of 1732 m<sup>2</sup>, and three main areas - halls, security and conference rooms and office spaces -. The purpose is to assess the environmental impact of three different Solar Control Film (SCFs) as retrofitting solutions and to compare these solutions with the replacement of the window with new one. The SCFs are different, for example SCF A is a reflective film with silver colour and a thickness of 0.050 mm as SCF B and C that are respectively tinted-yellow and not coloured. The results show that the carbon footprint normalised per m<sup>2</sup> of floor area in a period of 40 years in average is 4.73 kgCO<sub>2</sub>eq (SCF A has an emission of 4.26 kgCO<sub>2</sub>eq, SCF B has an emission of 5.20 kgCO<sub>2</sub>eq, SCF C has an emission of 4.73 kgCO<sub>2</sub>eq). In terms of carbon footprint, the new window, produces 35.93 kgCO<sub>2</sub>eq/m<sup>2</sup>/40 y, almost eight times higher than the average of the three films [1].



## **Energy efficiency**

The intelligent use of controlled EC glass and the orientation could optimise the comfort and considerably reduce energy demand in existing buildings through retrofitting interventions.

*Case study:* three independent single-room blocks located in the Faculty of Arts and Humanities' building of University of Coimbra (Portugal, csb zone). The test-cell models were based on the typical characteristics of school buildings of the 1950s, characterised by square layout, exterior walls 60cm thick, and windows placed at 1m from the floor and centred on the facade. Single and double glass with static optical properties and double EC glass were considered in the simulations. The results show that by adopting EC glass, in the cooling season the energy difference is 144.33 kWh in the east facade, 110.29 kWh in the south facade and 209.02 kWh in the west facade. Different values were carried out in the heating season: in the east facade the energy difference is 95.95 kWh, in the south facade is equal to 136.57 kWh and in the west facade is 152.08 kWh [2].

## **References**

[1] J. Pereira, C. Camacho Rivero, M. Glória Gomes, A. Moret Rodrigues and M. Marrero, *Energy, environmental and economic analysis of windows' retrofit with solar control films: A case study in Mediterranean climate*, Energy Volume 233(15 October 2021) 121083, <https://doi.org/10.1016/j.energy.2021.121083>

[2] P. Tavares, H. Bernardo, A. Gaspar, A. Martins, *Control criteria of electrochromic glasses for energy savings in mediterranean buildings refurbishment*, Solar Energy Volume 134 (September 2016) 236-250, <https://doi.org/10.1016/j.solener.2016.04.022>





# Glass with solar control: best practice

## Project name

The Sign

## Climate zone

Cfb - Subtropical highland climate

## Construction year

2021

## Location

Milan, Lombardy, Italy



## Integrated system

UTA  
photovoltaic solar system

## Certification

LEED 2009

## Health & Comfort

CO<sub>2</sub> sensors are provided in spaces with a high percentage of crowding. Automatic room temperature regulation systems thermal areas served by winter air conditioning systems are used in some of the rooms.

## Building materials

During the design phase, priority was given to the use of regional materials, with a very low content of volatile organic compounds and wood from certified forest.



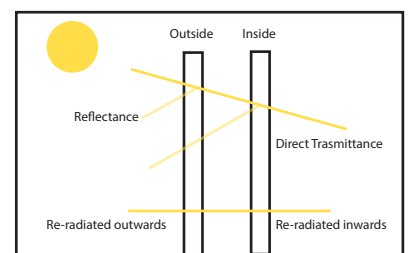
## Sustainability

The usage of local material combined to the glass with solar control reduce the carbon emissions in the phase of transportation and in terms of energy consumption. These two strategies combined to other system allows to reduce the global environmental impact of the building.



## How it works

Glass with solar control prevents a significant amount of sun's radiation thanks to three important features. The first one is the reflectance that is the proportion of solar radiation reflected into the atmosphere; the second feature is the direct, and the last is the absorptance. It is important to keep in mind that as the G Factor of the glazing is reduced, the visible reflection from the exterior of the glazing may increase and the glass can become tinted. Whilst there are many solar control-coatings available and the most popular is a 70/35 Solar control coating which reduces the G factor of the glass unit to 35% while maintaining the units light transmission at 70%. Solar control glass is not necessarily coloured or mirrored glass, although such finishes can be applied for aesthetic purposes if desired.



## Description

The sign, located in the south-east area of Milan, is a building of the 1950s. The project transforms Vedani Foundry in a new business district. The innovative project is characterised by three buildings united by a strongly contemporary and captivating facade, a series of golden flaps that alternate with the transparencies of glass. Since external shielding is not provided, the glazed windows ensure the reduction of 70% of the solar irradiation incident. The selective toughened glass Energy 72/38 from AGC's Energy range of magnetronic coatings, ensures the maximum level of natural light inside buildings and the minimum amount of heat. This product offers an excellent selection and a totally neutral appearance and, combined with other AGC products, it is an extremely versatile product able to guarantee maximum comfort.



# Adaptive skin



The adaptive skin is a building envelope that could be internal or external, without distinction between walls and roof. The term “adaptive” refers to a system with interactive behaviour. It constantly changes towards changing environmental conditions to enhance indoor comfort, glare protection, light deflection, heat and energy management, Indoor Air Quality (IAQ) and to reduce the carbon emissions. New generations of envelopes are emerging dynamic, autoreactive, responsive envelopes and kinetic characterised by different features, some types of facades may influence the performance of the load-bearing structure and its internal forces.

## Challenges



Energy sustainability



Temperature regulation



Water management



Health and wellbeing

## Objectives



Energy demand



Carbon impact



Energy produced from RES



Energy from RES on site



Local microclimate



UHI



Run off mitigation



Water scarcity



Water quality



Comfort and life quality



Urban space quality



Indoor thermal comfort



Lifespan



Easy to repair



Glare



Privacy



Noise pollution

## Performances



Low carbon material use



Greening



Energy efficiency



Temperature surface/air



Outdoor thermal comfort



Shadow effect



Water retention



Water storage and reuse



Water treatment



Green space



Space for socialization



Air quality



Walkability

## Regulations & Standards

UNI EN 13830

## Strategies



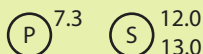
## Scale of application



## Space usage

Monofunctional  
Multifunctional

## S.D.G.



## Disadvantages

May negatively affect the view  
Reduction of usable space

# Energy consumption

---



## **Low carbon material use**

Several studies show that using adequate strategies such as adaptive skins, the carbon emission could be reduced by 50%-60%. Adaptive skin could be made of recycled material or with elements that could produce energy. The CO<sub>2</sub> saved depends on electricity mix, the facade orientation and the typology of the facade.

*Case study:* adaptive solar facade (ASF) at ETH house of natural resources living lab in Zurich (Switzerland). The facade consists of 45 dynamic PV modules composed of PV modules, actuator, and cantilever. The used cradle-to-grave approach contains the values of production, operation, and disposal of ASF. The results show that this kind of ASF gives a final emission of 3037 kgCO<sub>2</sub>-eq. Considering the energy savings produced by ASF the final emission decreases up to -8318 kgCO<sub>2</sub>-eq [1].



## **Energy efficiency**

Several studies show that the adaptive facade reduces solar gain and energy consumptions, with minimal reduction in visual comfort for users.

*Case study:* a rectangular building model located in a Cfb climatic zone, was used. The model contains six zones, in between a floor and external roof, with glazing north-south facades and west biomimetic facade. The simulations were performed assuming a different HVAC system that works in specific time slots and several functions. A comparison between the model with and without bioclimatic facade was performed. The results obtained show that, using a bioclimatic façade allows 46% of energy saving in the year. For the heating system the energy saved is 4,7 W/m<sup>2</sup> and for the cooling system the energy saved is 19 W/m<sup>2</sup>. The simulations conducted across building types show that the Aged Care model can reduce energy up to 67.1% compared to the reference case, the Education type indicates a reduction of 42.6% compared with the original, and for Office study a 46.2% reduction is obtained [2].

## **References**

- [1] L. Blandini, W. Haase, S. Weidner, M. Böhm, T. Burghardt, D. Roth, O. Sawodny and W. Sobek, *D1244: Design and Construction of the First Adaptive High-Rise Experimental Building*, Front. Built Environ., (06 June 2022), <https://doi.org/10.3389/fbuil.2022.814911>
- [2] M. Webb, *Biomimetic building facades demonstrate potential to reduce energy consumption for different building typologies in different climate zones*, Environ Policy 24, (18 August 2021) 493–518, <https://doi.org/10.1007/s10098-021-02183-z>



# Adaptive skin : best practice

## Project name

Kuggen - office building

## Climate zone

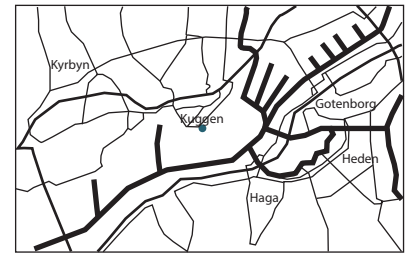
Cfb - Subtropical highland climate

## Construction year

2011

## Location

Gothenburg, Sweden



## Integrated system

Photovoltaic system,  
Solar panels

## Certification

Class A +

## Health & Comfort

The indoor thermal comfort is enhanced by the variable diffusers that provide VAV ventilation and cooling as required. In addition, the occupancy sensors provide both ventilation and lighting, according to the quantity of occupants.

## Energy consumption

60 kWh/m<sup>2</sup>/year



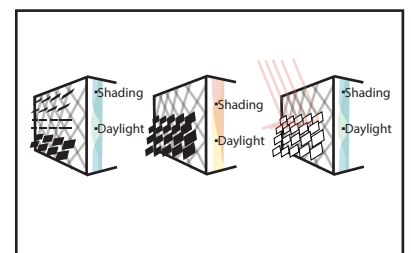
## Sustainability

Kuggen is characterised by innovative-adaptive technologies in terms of daylighting, heating/cooling, light and ventilation. In addition, the ceramic panels used in facade are made by a special technique that allows extending their use beyond the limits of our own civilization. They are so persistent that they can be reused.



## How it works

The adaptive building skin can change its properties and flexibly control the different parameters, according to climatic conditions to ensure thermal comfort. The change can be obtained in many different ways as moving elements, introducing air flows, through PMC materials, etc. According to the materials and the technology used, the adaptive skin could be called as kinetic, kinematic, dynamic, convertible, transformable, performative, responsive. In general terms, the vast category could be divided into opaque facades, which are basically made of layers of solid materials, such as stone, precast panels, etc.; and glazed facades, as curtain walls or storefront facades, which basically constructed with transparent glazing elements and metal framing structures.



## Description

Kuggen is the new building of Campus Lindholmen, designed by architect Gert Wingårdh. The purpose of the project is to create a kind of magnet that can attract students, businesspeople and the public, creating an innovative meeting place for the community. It has a circular shape with saw-tooth edge that provides shading to the storey-below, six floors and the triangular windows daylight to follow the ceiling deep into the building. It hosts 192 conform office units surrounding open, flexible space, destined to scientists working within Chalmers University of Technology setting up their start-up firms. The entire building is covered by a permanent-glazed terracotta skin made of six different shades of red and one green. A movable mesh-like system of photovoltaic cells sunscreen provides additional shade as well as electricity as it moves around the outer surface.



# Sunshade



Solar shading is an element of daylighting that can reduce glare and heat gain, by reflecting or blocking sunlight. The main design parameters, which alter the solar contribution, are the amount of wall area facing the sun, ratio of window/wall, wall orientation, etc. There is a wide variety of shading devices, basically divided into two categories: fixed (direction and path of the sun to optimise the effectiveness of shades need to be considered before the installation) and dynamic solar shades (they change throughout the day to respond to the sun's angle and strength). The common feature of both categories is the versatility of materials.

## Challenges

## Objectives

## Performances



Energy sustainability



Energy demand



Carbon impact



Energy produced from RES



Energy from RES on site



Low carbon material use



Greening



Energy efficiency



Temperature regulation



Local microclimate



UHI



Temperature surface/air



Outdoor thermal comfort



Shadow effect



Water management



Run off mitigation



Water scarcity



Water quality



Water retention



Water storage and reuse



Water treatment



Health and wellbeing



Comfort and life quality



Urban space quality



Green space



Space for socialization



Air quality



Walkability

Other benefits



Indoor thermal comfort



Glare



Cooling costs



Heat gain



Privacy



UV rays

## Regulations & Standards

## Strategies

## Scale of application



Building



Neighborhood



City



## Space usage

Monofunctional  
Multifunctional



## S.D.G.



7.3



11.b  
13.3



## Disadvantages

Unaesthetic  
exposed to atmospheric agents



# Energy consumption

---



## **Low carbon material use**

A cradle-to-grave environmental LCA was used to define the environmental performance in terms of CO<sub>2</sub> emission of the shadings in their all life stages. The analysis shows that the choice of shading material could have a strong environmental impact.

*Case study:* a one-story detached house model located in Seattle (Washington, USA). The residential building is characterised by a total floor area of 130m<sup>2</sup>, a height of 3.2m, and the total window to wall ratio was 18.87. The purpose is to assess the effect of various shading designs and materials such as wood, aluminium and PVC. The results show that the normalised global warming value is 3.02E-02 g CO<sub>2</sub> eq for the aluminium shadings, 1.24E-02 g CO<sub>2</sub> eq for the wood shadings and 3.27E-02 g CO<sub>2</sub> eq for the PVC shadings. It's shown that, in all studies, wood elements have the best environmental, economic and overall behaviour [1].



## **Energy efficiency**

Automatic control of shading is essential to save energy and provide daylight benefits.

*Case study:* some simulations for one/two person office cubicles have been performed in Oslo (Norway). The main characteristics of the office cells are the 3x3 m facade with a U-value of 0.15 W/m<sup>2</sup> K. Six strategies were adopted and each one was analysed in two different ways: with a fixed slat angle and with a variable slat angle. The results from the eleven cases, plus the twelfth case with no shading used as reference, show that the energy demand could be reduced by 9% if the right shading strategy is chosen on the south-facing facade. Moreover, it was found that improper use of shading systems on the north-facing could lead to an increase of the total energy demand by 10%. In addition, upgrading to four-pane glazing have a beneficial impact on the energy demand. A significant reduction of 20% is noted by the replacement of two-pane glazing with four panes, and a reduction of 7% by the replacement of the three-pane window with a four-pane glazing unit [2].

## **References**

- [1] H. Babaizadeh, N. Haghighi, S. Asadi, R. Broun and D. Riley, *Life cycle assessment of exterior window shadings in residential buildings in different climate zones*, Building and Environment 90 (August 2015) Pages 168-177, <https://doi.org/10.1016/j.buildenv.2015.03.038>
- [2] S. Grynning, B. Time, B. Matusiak, *Solar shading control strategies in cold climates – Heating, cooling demand and daylight availability in office spaces*, Solar Energy 107 (September 2014) 182-194, <https://doi.org/10.1016/j.solener.2014.06.007>



# Sunshade: best practice

## Project name

BUM - Biblioteca Universitaria Mesiano

## Climate zone

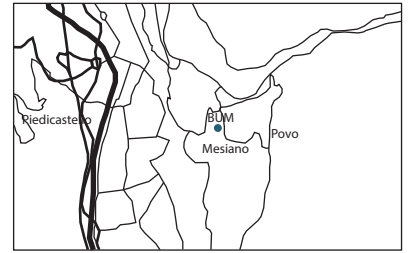
Cfb - Subtropical highland climate

## Construction year

2021

## Location

Trento, Trentino, Italy



— River  
— Highway  
— Roads

## Integrated system

Geothermal system

## Certification

Class A +

## Health & Comfort

The energy efficiency feature and the use of "solar shade" that prevents overheating in summer and heating in winter, greatly improving the quality of users' life.

## Energy consumption

7.27 kWh/m<sup>3</sup> /year for heating  
5.32 kWh/m<sup>3</sup> /year for cooling  
1.48 kWh/m<sup>3</sup> /year for DHW



## Sustainability

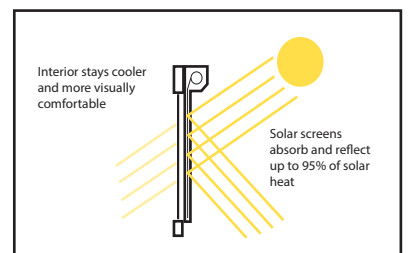
All the materials used make the building more sustainable, for example the furniture follows the minimum environmental criteria (CAM): dimerable led lamps, concrete made of recycled aggregates with porphyry waste in a variable percentage between 75% - 80%, windows and floors with high thermal break guaranteeing non-toxicity due to formaldehyde and heavy metal content, and 180m<sup>2</sup> lamination tank recovering water for irrigation.



## How it works

They block up to 97% of the heat and UV rays before the sun enters through the window. This system allows to dissipate or reflect bulk of the heat absorbed by the screen, and to control heat gain by rolling down exterior solar shades on hot days to block the heat and rolling the shade up when it isn't necessary. The choice of shading devices depends on several parameters. The key factor is the context compatibility, followed by the regulation of light, the right ventilation, durability, costs.

In addition, according to the compatibility with style and urban language some different solar shades could be used, as pull up and down and open inwards or outwards, in different shapes as venetian blinds, shutters, textile solutions.



## Description

The BUM building has almost 1500m<sup>2</sup> in 3 floors: one above ground, one basement and the underground for technical services. It is built with reinforced concrete structures with large-glazed openings that allow the 320 occupants to enjoy an excellent view as well as excellent thermal comfort. On sunny days the windows are covered by grey-textile shade devices that pull up and down according to the sun rays and the heat load. Interior comfort is guaranteed by the sunshades, the construction of oak wood floors and ceiling panels with sound-absorbing materials, underfloor heating, high-efficiency windows with acoustic cut, brightness control by sensors for measuring natural light and regulation of artificial light via dimerators that allow home automation self-regulation. In addition, the used colours as black, oak colour and grey, makes the rooms welcoming and suitable for concentration.



# Phase changing material

When air temperature rises, phase change materials (PCMs) absorb heat, with an endothermic change from solid to liquid. As air temperature drops again, the PCMs will return to the solid state and give off the absorbed heat. PCMs can be divided into several subcategories based on their chemical composition: (i) organic compounds (paraffins/non-paraffins), (ii) inorganic compounds and (iii) inorganic eutectics mixtures. In addition, they could be incorporated into building envelope elements by immersion, micro or macro encapsulation, shape-stabilised PCMs, and form-stable PCM composites. This cycle stabilises the indoor temperature, cuts off-peak cooling loads and decreases heating loads, not by affecting the thermal resistance of the building envelope but by influencing the (surface) temperatures.



## Challenges

## Objectives

## Performances



Energy sustainability



Energy demand



Carbon impact



Energy produced from RES



Energy from RES on site



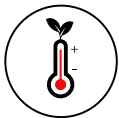
Low carbon material use



Greening



Energy efficiency



Temperature regulation



Local microclimate



UHI



Temperature surface/air



Outdoor thermal comfort



Shadow effect



Water management



Run off mitigation



Water scarcity



Water quality



Water retention



Water storage and reuse



Water treatment



Health and wellbeing



Comfort and life quality



Urban space quality



Green space



Space for socialization



Air quality



Walkability

Other benefits



Indoor thermal comfort



Reuse



Cooling costs



Heat gain



Fire resistant



Noise pollution

## Regulations & Standards

## Strategies

## Scale of application



## Space usage

## S.D.G.

## Disadvantages

Monofunctional  
Multifunctional

P 7.0 S 13.2  
S 13.3

Poor thermal conductivity  
PCM performance is limited

# Energy consumption

# Temperature regulation



## Low carbon material use

Several studies show the PCMs could reduce the carbon emission of the buildings. Typically, the carbon quantity depends on PCM thickness and surface area, local, weather and used materials.

*Case study:* a typical Australian home was simulated in Newcastle (Australia, cfa zone).

The model is characterised by a floor area of 6 x 5 m a height of 2.5 m, and two identical 2 x 1 m<sup>2</sup> windows in the southern and in northern parts. The aim is to calculate the environmental impact of six model modes. The simulation results show that using PCM the amount of CO<sub>2</sub> could decrease up to 4,917 kg/year by oil, 3073 kg/year by natural gas and 6146 kg/year by coal. The worst-case scenario is represented by the PCM positioned in the roof-wall of the building, when the amount of CO<sub>2</sub> emissions is 2433.2 kg. Globally, considering the entire building with a life span of 50 years, the total CO<sub>2</sub> reduction is about 264 tons, less than 1%, therefore, the carbon footprint would be negligible [1]. Another interesting case [3].

## Energy efficiency

The PMC technology could capture heat, create a real thermal energy storage and be a valid solution for heating and cooling. The PCM performance depends on the temperature, thermal conductivity and density.

*Case study:* energy simulation of an office with 4 m x 3 m x 2.8 m. The building is characterised by a solar collector that sends air into TES where it releases heat to PMC plates, facing south, 3 m<sup>2</sup> of windows. In addition, ventilation, infiltration, and temperature values have been set. The results show that, during the winter, using PMC plates, the energy saved is about 84 kWh, that is the 8% of the heat load accumulated by PCM storage. In summertime, the energy saved is approximately 58 kWh. Using PCM technology, approximately 142 kWh of energy could be saved in an office [2]. Another interesting case [4].



## Temperature surface/air

Recent studies have been investigating the combination of cool materials and thermal storage effect as a passive strategy to contribute to the mitigation of the urban heat island effect, besides improving the thermal-energy efficiency of buildings.

*Case study:* prototype of building envelope with PCM for roofing applications (in-lab test). The test involved an innovative cool polyurethane-based membrane with organic (paraffin-based) PCM performed on the material and product scale.

The testing of the technology was performed through morphological nanoscale analysis, thermal-optic characterization and thermal experimental characterization. The main aim of the tests is to evaluate the possibility to include PCMs into waterproof membranes in the roofs to have a cooling effect. The study gave promising results, but the performance can be optimized [5].



## References

- [1] E. Mohseni and W. Tang, *Parametric analysis and optimisation of energy efficiency of a lightweight building integrated with different configurations and types of PCM*, Renewable Energy 168 (May 2021) Pages 865-877, <https://doi.org/10.1016/j.renene.2020.12.112>
- [2] E. Osterman, V. Butala, U. Stritih, *PCM thermal storage system for 'free' heating and cooling of buildings*, Energy and Buildings Volume 106 (1 November 2015) Pages 125-133, <https://doi.org/10.1016/j.enbuild.2015.04.012>
- [3] A. Gracia, R. Barzin, C. Fernández, M. M. Farid and L. F. Cabeza, *Control strategies comparison of a ventilated facade with PCM – energy savings, cost reduction and CO<sub>2</sub> mitigation*, Energy and Buildings Volume 130 (15 October 2016) Pages 821-828, <https://doi.org/10.1016/j.enbuild.2016.09.007>
- [4] F. Bruno, N.H.S.Tay and M. Belusko, *Minimising energy usage for domestic cooling with off-peak PCM storage*, Energy and Buildings Volume 76 (June 2014) Pages 347-353, <https://doi.org/10.1016/j.enbuild.2014.02.069>
- [5] A.L. Pisello, E. Fortunati, S. Mattioli, L.F. Cabeza, C. Barreneche, F. Cotana, *Innovative cool roofing membrane with integrated phase change materials: Experimental characterization of morphological, thermal and optic-energy behavior*, Energy and Buildings Volume 112 (January 2016) Pages 40-48, <https://doi.org/10.1016/j.enbuild.2015.11.061>



# Phase changing material: best practice

## Project name

Solar House

## Climate zone

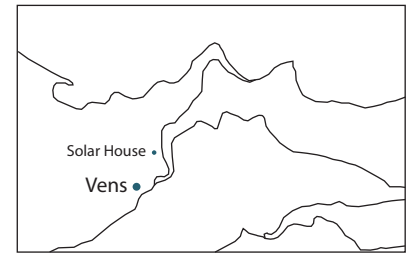
Dfb

## Construction year

2010 - 2011

## Location

Vens, Aosta Valley, Italy



## Integrated system

The only other energy source is wood for the cooking stove.

## PCM material

Calciumchloridehexahydrate ( $\text{CaCl}_2 \cdot 6\text{H}_2\text{O}$ ), a nontoxic salt, with melting point at room temperature.

## PCM system

GLASSX® crystal - all-in-one facade element composed by PCM core layer, insulation glazing and integrated shading.

## System characteristics

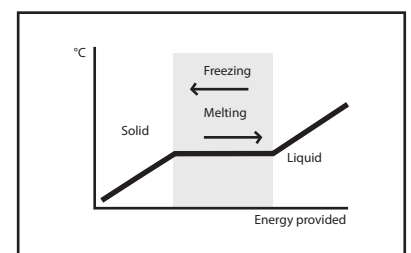
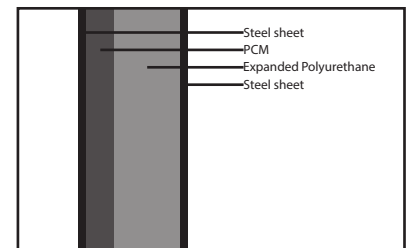
Translucence, optimal insulation, seasonally-variant shading.



## How it works

PCM are substances that absorb heat when on the external envelope surface the maximum incoming heat flux is present during the hot hours of the day. When the temperature decreases to the melting point, the latent heat stored by PCM is subsequently released. A phase displacement of heat flux is generated by this storage-release cycle. This process allows to reduce cooling peak load between the daytime and the night-time. These kinds of materials are suitable for several different applications, because of their melt and solidify specific temperature allow to control the temperature. This property improves the efficiency of the material, for this reason, compared to a conventional material, the PCM is used in a smaller amount.

There are several factors should be considered when selecting a phase change material such as high heat of fusion, high thermal conductivity, high specific heat and density, long term reliability during repeated cycling, and dependable freezing behaviour. In addition, there are several classes of phase change materials such as paraffin waxes, non-paraffin organics, and liquid-to-gas phase change materials.



## Description

The project is designed to enhance the stunning view of the context and to take advantage of the sun exposition. The building is at 1750 meters above sea level in a small village of the Alps. The structure is made of a wooden frame of weight bearing walls, which are let visible in the south facade. The house used solar energy in a bifold way: direct accumulation through the windows in the south facade, stored and slowly released by the mineral salts of the PCM panes; electricity production through photovoltaic panels on the roof.





# Ventilated facade

A ventilated facade is an exterior building envelope system that can be installed on both new and existing buildings. It has a double function: it is practical and aesthetically attractive from an architectural point of view, and it moderates the exchange of heat and air. Typically, the ventilated facade comprises five main parts: base material, insulation, ventilation gap, substructure, and facade panel. The external layer could be made by porcelain stoneware, aluminium composite panels, fiber cement panels, high pressure laminate panels, linear slabs, glass panels. In addition, it could be combined with some other innovative solutions such as PCM.



## Challenges



Energy sustainability



Temperature regulation



Water management



Health and wellbeing

## Objectives



Energy demand



Carbon impact



Energy produced from RES



Energy from RES on site



Local microclimate



UHI



Run off mitigation



Water scarcity



Water quality



Comfort and life quality



Urban space quality



Indoor thermal comfort



Flexibility



Noise pollution



Mold



Thermal insulation



Easy to repair

## Performances



Low carbon material use



Greening



Energy efficiency



Temperature surface/air



Outdoor thermal comfort



Shadow effect



Water retention



Water storage and reuse



Water treatment



Green space



Space for socialization



Air quality



Walkability

## Regulations & Standards

UNI 11018, UNI 8012, UNI EN 12152, UNI EN 12153, UNI EN 12179, UNI EN 13116

## Strategies



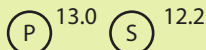
## Scale of application



## Space usage

Monofunctional  
Multifunctional

## S.D.G.



## Disadvantages

Low fire safety  
Susceptible to corrosion

# Energy consumption



## **Low carbon material use**

Different studies show that ventilated facades can reduce the carbon footprint, save energy, and guarantee indoor thermal comfort.

*Case study:* the “Polígono San Pablo” building, built in 1962, located in Seville (Spain, csa zone). It is characterised by 4 floors, with two houses per floor, for a total of 8 houses composed by living-dining room, kitchen, laundry room, bathroom, toilet, four bedrooms, and distribution space. The aim is to compare the conventional facade made up external coating of granite slabs, ceramic bricks, busbar layer, insulation, double hollow brick partition, inner coating and the windows have aluminium frames; with the new prototype facade composed by external coating cladding, thermal insulation, ceramic bricks and all the layers of conventional facade. The results show that some features of the new facade have a strong impact on the CO<sub>2</sub> emission. Comparing the two facade, it's notable that the window frame emits 31.70 kgCO<sub>2</sub>/m<sup>2</sup> less than the conventional one, for the exterior cladding difference is 19.40 kgCO<sub>2</sub>/m<sup>2</sup>, and for thermal insulation, the difference is 42.48 kgCO<sub>2</sub>/m<sup>2</sup> [1].



## **Energy efficiency**

Several studies show that the ventilated facades can bring several benefits, including improvement of the energy building performance.

*Case study:* the comparison between an opaque ventilated (OVF) and an unventilated facade (UF) located in Catania (Italy, csa zone), using fluid-dynamic simulations. The unventilated element is made up of inner plaster, brick wall, cement mortar, insulation of rock wool. The opaque ventilated facade is like the conventional one, with the addition of an air cavity, a layer of brick slabs and two openings placed at the bottom and the top of the facade to improve the chimney effect. The aim is to calculate energy savings for different facades in different conditions of wind, in summertime and wintertime. The results show that during the winter season the energy-saving (ES) achievable by the OVF is up to 20.0 for East /West facade under windy conditions, and up to 50.0% for the South facade under calm wind conditions. The situation changes in the summer season. The ES achieved by OVF is in the range from 40.0% to 50.0%, depending on the orientation of the facade and the wind conditions [2].

## **References**

- [1] P. Mercader-Moyano, P. Anaya-Durán and A. Romero-Cortés, *Eco-Efficient Ventiladed Facades Based on Circular Economy for Residential Buildings as an Improvement of Energy Conditions*, Energies 2021, 14 (November 2021), 7266, <https://doi.org/10.3390/en14217266>
- [2] A. Gagliano and S. Aneli, *Analysis of the energy performance of an Opaque Ventiladed Facade under winter and summer weather conditions*, Solar Energy 205 (15 July 2020) Pages 531-544, <https://doi.org/10.1016/j.solener.2020.05.078>



# Ventilated facade : best practice

## Project name

Humanitas University Campus

## Climate zone

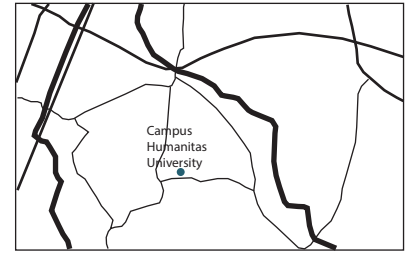
Cfb - Subtropical highland climate

## Construction year

2017

## Location

Pieve Emanuele (Milan), Lombardy, Italy



## Integrated system

Geothermal pump,  
Solar thermal and  
Photovoltaic panels

## Certification

Class A2

## GHG emissions

23,09 KgCO<sub>2</sub>/m<sup>2</sup>/year

## Primary energy

103,95 kWhpe/m<sup>2</sup>/year



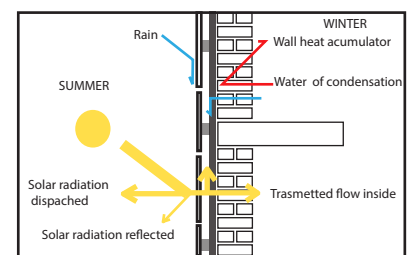
## Sustainability

To pursue the sustainable goals, some solutions have been adopted, such as: the installation of low energy LED lighting, photovoltaic and solar thermal panels in the roof, shading system as venetian blind and brisee-soleil for internal shading, glazed facade with thermal cutout to improve energy efficiency, and natural lighting guaranteed by the right exposure and orientation of the building.



## How it works

The air cavity in between the exterior cladding and the wall allows the air convective movement. This phenomenon is based on the difference between the internal and external temperature, therefore is a function of context, orientation, geometry, and exposure. The convective movement characterised the efficiency of the ventilated facade. In summertime, temperature increase in the cavity generates a "chimney effect" that pushes the air upwards, thus reducing the wall's temperature facing the inside of the building. During wintertime, the openings balance the wall's temperature and reduce the risk of moisture from condensation.



## Description

The Campus Humanitas University is the new International University of Medicine in Rozzano (Mi). The project is designed for 1000 students and consists of four buildings that will host teaching activities, a research unit, a multifunctional hub with a canteen and a library, and a student residence. The main buildings of the campus - didactics, hubs, and research - are covered by a ventilated facade made up of stone panels fixed to the wall with punctual aluminium couplings. This kind of anchorage allows the panels to be detached from the main wall and create the air cavity. The new skin has been planned to ensure a proper insulation in terms of energy efficiency and protection against atmospheric agents. The local material used for finishes allows to the building to be able to save the part of the costs for transportation, as well as to ensure a direct relationship between the manufacturer and the supplier.



# Double Skin



The double skin façade system typically is composed by two layers (typically glass) that allows airflow through the in-between space of 20 cm to 2 m. This layer increases thermal insulation, thermal efficiency and at the same time, reduces winds and sound. The double-skin facade can be used as an active or passive system. A double-skin facade is a complex concept, commonly classified according to three parameters: type of ventilation, geometry of the cavity, and airflow path inside the cavity. Regarding geometry, double-skin facades can be divided into four distinct groups: box-window, shaft-box and multi-storey double-skin facade.

## Challenges

## Objectives

## Performances



Energy sustainability



Energy demand



Carbon impact



Energy produced from RES



Energy from RES on site



Low carbon material use



Greening



Energy efficiency



Temperature regulation



Local microclimate



UHI



Temperature surface/air



Outdoor thermal comfort



Shadow effect



Water management



Run off mitigation



Water scarcity



Water quality



Water retention



Water storage and reuse



Water treatment



Health and wellbeing



Comfort and life quality



Urban space quality



Green space



Space for socialization



Air quality



Walkability

Other benefits



Indoor thermal comfort



Flexibility



Noise pollution



Cooling effects



Thermal insulation



Longer lifespan

## Regulations & Standards

## Strategies

## Scale of application



Space usage

Monofunctional  
Multifunctional



S.D.G.



13.0



-



Building



Neighborhood



City



Disadvantages

Overheating issues  
More weight to the structure

# Energy consumption

---



## **Low carbon material use**

Improvements to the facade, using the double skin facade, is one of the most effective strategies to reduce carbon footprint.

*Case study:* an office building located in London (England), composed of nine floors, 9,590 m<sup>2</sup> and naturally ventilated. The purpose of the study is to make a comparison between SSF (single skin facade) and the DSF (double skin facade) and to underline that the DSF can outweigh the GHG impacts. The results show that the best configuration made with a narrow cavity could save up to more than 2,500 of kg CO<sub>2</sub>-eq over the service life, against the 1,000 of kg CO<sub>2</sub>-eq saved using SSF. Pomponi et al. (2015) show that 67% of UK offices could be refurbished using DSF, therefore over 17 million MWh and 3.5 Mt CO<sub>2</sub>-eq could be saved [1].



## **Energy efficiency**

A double skin facade could be used as a passive system to improve building energy efficiency and indoor thermal comfort.

*Case study:* a simplified double skin facade model located in central Spain was used for the study. The model is characterised by a double skin facade facing south of 3 m high and 6 m wide, and the air cavity that is extended the whole height of the model. Eight different cases were simulated with 29 facade configurations studied in different conditions as summer, winter, with cavity opened or closed, considering solar radiation or not, for a total of 116 cases. The results show that in the winter scenario, the energy saving with solar radiation and vents closed, is 75,1% against the 52,3 % without solar radiation. In the summer scenario, the energy saving with solar radiation and vents opened is 4,0% against the 44,3 % without solar radiation and vents closed [2].

## **References**

- [1] F. Pomponi, Poorang A.E. Piroozfar, Eric R.P. Farr, *An Investigation into GHG and non-GHG Impacts of Double Skin Façades in Office Refurbishments*, Journal of Industrial ecology 20 – issue 2 (April 2016) 234 – 248, <https://doi.org/10.1111/jiec.12368>
- [2] E. Sanchez, A. Rolando, R. Sant, L. Ayuso, *Influence of natural ventilation due to buoyancy and heat transfer in the energy efficiency of a double skin facade building*, Energy for Sustainable Development 33 (August 2016) Pages 139-148, <https://doi.org/10.1016/j.esd.2016.02.002>





# Double Skin: best practice

## Project name

Renovation of the school gym – middle school “DANTE ALIGHIERI”

## Climate zone

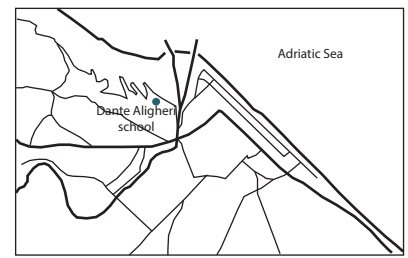
Csa - Hot-summer Mediterranean climate

## Construction year

2010

## Location

Gattoni, Marche, Italy



## Integrated system

Solar panel  
Photovoltaic panels

## Certification

Class A +

## GHG in use

7,00 KgCO<sub>2</sub>/m<sup>2</sup>/year

## Primary energy

22,00 kWhpe/m<sup>2</sup>/year

## GHG Cradle to Grave

8,55 KgCO<sub>2</sub>/m<sup>2</sup>

## Renewable energy

59,67 %



## Sustainability

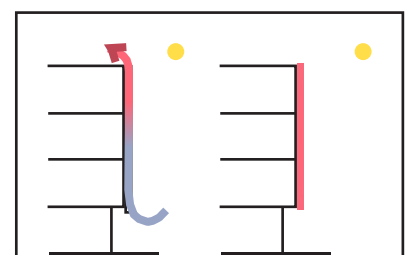
The method of dry construction and use of natural materials make the building more sustainable, creating a healthy space in which to live. In addition, the use of some materials such as the rock wool of different densities, the ventilated wall panels and fibre cement isolate the envelope and save energy for heating during winter, and for cooling during the summer.



## How it works

The double skin facade is usually made by a high resistance laminated glass, which normally covers the entire building, supported by metal brackets, and connected to the building structure. The outer layer has a high incident solar radiation index that allows the glass temperature to increase and air heats up within the confined cavity due to the convective heat exchanges.

Due to the stack effect, the warm air becomes less dense and rises through the facade. The action of the wind on the building could create positive pressure at the bottom and negative pressure at the top outlet of the facade. This phenomenon depends on the geometry of the facade and on the location of the openings.



## Description

The school “Dante Alighieri” has an area of 4.200 m<sup>2</sup> and it is divided into three volumes, the school for 560 pupils, the gym and the auditorium. The 60's building is characterised by the skeleton of a steel frame, and by heavy concrete panels as a sandwich. In 2010, some interventions were adopted to make suitable for seismic regulations and to provide an envelope that could reduce energy consumption in terms of heating and cooling demand. Practically, control of heat loss, ventilation control, noise control, comfort indoor and a shell of double skin facade panels are the most important strategies used. The shell is made of fibre cement panels that, during manufacturing, receives a unique surface treatment which makes them waterproof and resistant. The panels are characterised by slight colour variations that make the building more attractive. In addition, attention was paid not only on the finishes, but also on orientation, temperature, damp, direction of the dominant winds, summer sea breezes to make the building more efficient.



# Natural ventilation

Natural ventilation is a passive strategy that utilises the natural power of wind to enter fresh air and spread it in buildings. It works using the pressure difference among rooms or between inside and outside, therefore it doesn't require energy. Typically, the occupants open windows and allow air to enter or leave. According to the opening's orientation, the "chimney effect" could be generated. There are basically two kinds of natural ventilation: the first is wind-based ventilation, and the second is stack-effect. Nevertheless, the choice of ventilation system depends on several parameters such as geometry, orientation, exposure.



## Challenges

## Objectives

## Performances



Energy sustainability



Energy demand



Carbon impact



Energy produced from RES



Energy from RES on site



Low carbon material use



Greening



Energy efficiency



Temperature regulation



Local microclimate



UHI



Temperature surface/air



Outdoor thermal comfort



Shadow effect



Water management



Run off mitigation



Water scarcity



Water quality



Water retention



Water storage and reuse



Water treatment



Health and wellbeing



Comfort and life quality



Urban space quality



Green space



Space for socialization



Air quality



Walkability

## Other benefits



Indoor thermal comfort



Mold



Cooling costs



Flexibility



Noise pollution



Daylight

## Regulations & Standards

EN 15242, ISO 12569 and EN 15251

## Strategies



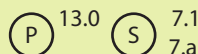
## Scale of application



## Space usage

Monofunctional  
Multifunctional

## S.D.G.



## Disadvantages

Weather dependent  
Hard to control

# Energy consumption



## **Low carbon material use**

Natural Ventilation Systems (NVS) are one of the passive strategies to save up to 50% in CO<sub>2</sub> emissions, depending on the heating fuel used and the zone where the building is located.

*Case study:* a comparison between the school building models A.1 and B.1, in Andalusia (Spain, different zones). The A.1 model is characterised by NVS with stacks and air admission on facade; an opposite case is represented by the B.1 model characterised by a mechanical ventilation system. The purpose of this study is to compare the CO<sub>2</sub> emission of NVS which has cross ventilation, stacks and automatic ventilation with MVS. The results show that, depending on the zone, MVS can produce more than a maximum of 49,80% of CO<sub>2</sub> emission in C4 zone (Jaen, Spain) to a minimum of 31,18% in A4 (Almeira, Spain), compared to the natural ventilation system. According to these results, the 5000 schools of Andalusia could reduce their emission by about 46,500 tons of CO<sub>2</sub> with the application of NVS [1]. Another interesting case [2].



## **Energy efficiency**

Several studies show that the natural ventilation system can improve up to 9.7% the building energy efficiency compared to a building without this kind of system.

*Case study:* a typical one-floor modular familiar dwelling located in the Polytechnic University of Valencia (Spain, Bsk zone). The building is composed of three rooms, a pergola at the entry and shadows in the windows. Three cases A, B, C are compared to determine the architectural solution that best improves the NV behaviour in the building. Case A has no lateral window, case B has right window in the east face and case C has left window in the east face. The results show that the best case that reduces up to 1.13 kWh/m<sup>2</sup> the energy consumption is the Case C. In addition, the global energy behaviour is approximately improved by 4.12% [2]. Another interesting case [3].

## **References**

- [1] M. Gil-Baez, Á. Barrios-Padura, M. Molina-Huelva, R. Chacartegui, *Natural ventilation systems in 21st-century for near zero energy school buildings*, Energy 137 (15 October 2017) Pages 1186-1200, <https://doi.org/10.1016/j.energy.2017.05.188>
- [2] M. Mora-Pérez, I. Guillen-Guillamón, G. López-Patiño, P.A. López-Jiménez, *Natural Ventilation Building Design Approach in Mediterranean Regions - A Case Study at the Valencian Coastal Regional Scale (Spain)*, Sustainability 8 (2016) 855, <https://doi.org/10.3390/su8090855>
- [3] Babak Raji, Martin J. Tenpierik, Regina Bokel & Andy van den Dobbelen, *Natural summer ventilation strategies for energy-saving in high-rise buildings: a case study in the Netherlands*, International Journal of Ventilation, 19:1, 25-48, <https://doi.org/10.1080/14733315.2018.1524210>



# Natural ventilation: best practice

## Project name

Casa UD

## Climate zone

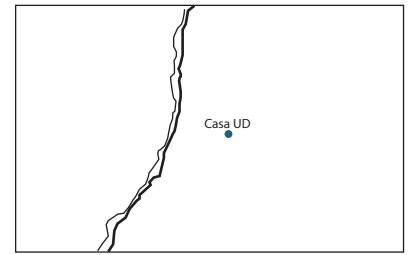
H - Highland Climate (mountainous terrain)

## Construction year

2017

## Location

Chamois, Valle d'Aosta, Italy



— River  
— Highway  
— Roads

## Integrated system

Solar photovoltaic

## Primary energy

11.74 kWhpe/m<sup>2</sup>/y

## Health & Comfort

The usage of natural ventilation systems allow the temperature and humidity to remain constant even with significant climatic variations on the outside. It improves the quality of the user's life.

## Environmental Quality

- indoor air quality and health
- comfort (visual, thermal, acoustics)
- energy efficiency
- renewable energies
- integration in the land



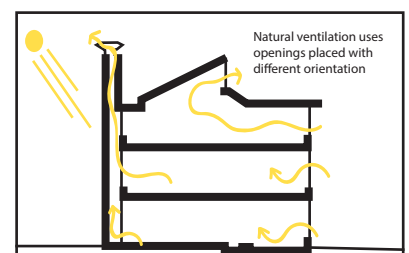
## Sustainability

The right position of the openings allows the correct crossed air flow and the complete exchanging of air. The building is made sustainable using exclusively eco-design materials that don't contain toxic substances. The natural materials used, for example, are recycled cellular glass plates and sheep's wool for insulation, raw earth for plaster, stone for external covering, and so on.



## How it works

Natural ventilation system is a highly effective, user-friendly, and passive way to make the house cooler without using energy. Each designer should combine the aesthetic feature of the window with its function. If the combinations of openings are accurately studied, the natural ventilation can change the entire volume of air, to remove each kind of odours, to allow a breeze to come through while removing the warm air. In other words, it's an effective way to cool down a house during summertime. To improve this system it's necessary to introduce different openings in size and position along different facade.



## Description

Casa UD is an almost zero-energy house built on the remains of an old dry-stone cottage built in 1834. Due to the impossibility to easily reach the site, the load-bearing structure of the roof, walls and floors in prefabricated wood frame were assembled in 4 days using a helicopter. The house is composed of a kitchen, dining and relax area on the ground floor, the master bedroom and bathroom on the first floor, and two bedrooms with mezzanine at the last one. The innovative aspects of the project are basically the construction technique, the usage of local materials that reduced to a minimum the environmental impact, and the absence of the heating system. The presence of big glazed-windows along the south facade, combined with some different small openings on the East and West facade, ensure the passive contribution of the sun, ventilation, and natural lighting.



# Night cooling



Night cooling, known also as night-purge ventilation or night flushing, is a passive technique that uses the building's thermal mass as a sink during the day as it absorbs heat gains from occupants and the sun. When evening temperatures drop, the building envelope is opened, allowing cool air to enter the building and dissipate the stored heat via convection. Night cooling can be used in a natural, mechanical, or mixed-mode ventilation approaches. All approaches offer the potential to improve the internal conditions and to avoid the overcooling and subsequent re-heating or thermal discomfort the following day.

## Challenges

## Objectives

## Performances



Energy sustainability



Energy demand



Carbon impact



Energy produced from RES



Energy from RES on site



Low carbon material use



Greening



Energy efficiency



Temperature regulation



Local microclimate



UHI



Temperature surface/air



Outdoor thermal comfort



Shadow effect



Water management



Run off mitigation



Water scarcity



Water quality



Water retention



Water storage and reuse



Water treatment



Health and wellbeing



Comfort and life quality



Urban space quality



Green space



Space for socialization



Air quality



Walkability

## Other benefits



Indoor thermal comfort



Easy to repair



Cooling costs



Weather protection



Daylight



Mold and condensation

## Regulations & Standards

## Strategies

## Scale of application



## Space usage

Monofunctional  
Multifunctional



## S.D.G.

P - S 11.0  
13.0



## Disadvantages

Noise pollution  
Air pollution



Building



Neighborhood



City



# Energy consumption



## Low carbon material use

Several studies show that the well-designed night cooling strategy could extremely decrease the carbon footprint. For this purpose, it's necessary to accurately study the orientation, the geometry, the position of windows and the climate zone.

*Case study:* newly built FOS/BOS school building in Erding (Germany). It is composed of three blocks, the four-storey north building and three-storey south building connected with a fully glazed atrium that hosts various spaces including a lecture room, offices, IT room, laboratory, storeroom, toilet, common room, kitchen, etc. It was designed for 750 students according to Passive House standards. The results show that using night cooling the energy used for cooling is extremely reduced. The CO<sub>2</sub> equivalent emission was estimated for the energy consumption of the heating system and the electricity use. The results show that the CO<sub>2</sub> equivalent emission is 88.1 t/a, which is about one-third of the CO<sub>2</sub> emitted by standard school (281 t/a) [1].



## Energy efficiency

The combination between natural or mechanical ventilation with thermal inertia, drastically decreases energy consumption. Some other important parameters that influence the performances are geometry, windows ratio, orientation, climate zone and materials used.

*Case study:* An isolated office building with dimensions 16 m x 24 m x 18 m located in Bergamo (Italy). It is composed of six floors; each floor has twelve office rooms aligned on the northern and southern sides of the building. To achieve cross-ventilation, operable bottom-hung openings are added. The building is characterised by the presence of shading devices, by high thermal inertia and other setpoint parameters as Cp (pressure coefficient), ACHN, etc. The simulation in Energy Plus shows that, the energy saving (ES) is lower from 33.7% to 32.0% when the exposed thermal mass has a lower thermal inertia, since the heat stored in the thermal mass is reduced. Clearly for a given value of ACHN, the lower the night-averaged outdoor temperature the higher are the energy savings [2].

Another interesting case is [3].

## References

- [1] Y. Wang, J. Du, J. M. Kuckelkorn, A. Kirschbaum, X. Gu and D. Li, *Identifying the feasibility of establishing a passive house school in central Europe: An energy performance and carbon emissions monitoring study in Germany*, Renewable and Sustainable Energy Reviews Volume 113 (October 2019) 109256, <https://doi.org/10.1016/j.rser.2019.109256>
- [2] R. Ramponi, A. Angelotti and B. Blocken, *Energy saving potential of night ventilation: Sensitivity to pressure coefficients for different European climates*, Applied Energy 123 (15 June 2014) Pages 185-195, <https://doi.org/10.1016/j.apenergy.2014.02.041>
- [3] R. Guo, Y. Hu, P. Heiselberg, H. Johra, C. Zhang and P. Peng, *Simulation and optimization of night cooling with diffuse ceiling ventilation and mixing ventilation in a cold climate*, Renewable Energy Volume 179 (December 2021) Pages 488-501, <https://doi.org/10.1016/j.renene.2021.07.077>



# Night cooling: best practice

## Project name

EcoHotel Bonapace

## Climate zone

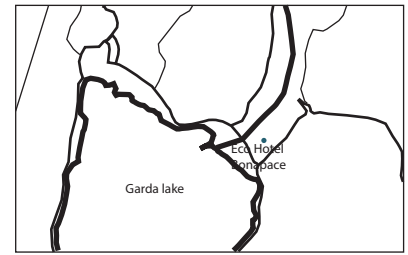
Cfb - Subtropical highland climate

## Construction year

2012

## Location

Nago Torbole, Trento, Trentino, Italy



— River  
— Highway  
— Roads

## Integrated system

Geothermal system  
Solar panels  
Photovoltaic panels

## Certification

CasaClima Climahotel Oro  
Passivhaus  
Arca Platinum

## Health & Comfort

The building is equipped with a basic demotic system that controls the ventilation / heating or cooling systems/ external shading devices.

## Energy consumption

12 kWh/m<sup>2</sup> year,  
7,42 kWh/m<sup>2</sup> year for heating system

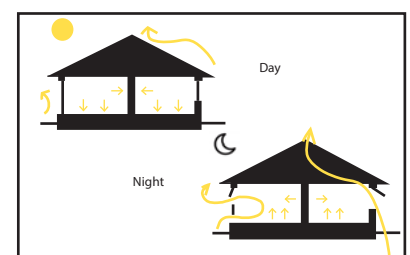


## Sustainability

The building is made of a new material developed in Trentino made of cross-laminated wood panels with outstanding structural features (earthquake response, lightness, fireproofing resistance, etc.). The wood used respects the PEFC standard. The structure is covered externally by thick insulation layers made of recycled material. In addition, all the internal and external plaster-covers are made of natural components. Finally, the building is characterised by the green roof that helps to reduce the UHI effect.

## How it works

During the day, the building is closed to prevent warm air entering from outside. The cool mass absorbs heat from occupants and other internal loads. Throughout the night, using pathways for wind ventilation, the thermal mass cools down. Using natural ventilation for the cooling also requires a relatively unobstructed interior to promote air flow. Because the "coolth" of night-purge ventilation is stored in thermal mass, it requires a building with large areas of exposed internal thermal mass. This means not obscuring floors with carpets and coverings, walls with cupboards and panels, or ceilings with acoustic tiles and drop-panels. The night purge is one of the cheaper and most efficient strategy, but this system has some limitations due to climate, security concerns, and usability factors.



## Description

The Ecohotel Bonapace is a three-story building located 1 km far from Garda Lake, in northern Italy. To optimise the ratio between internal and external surface and the heating/cooling losses, the footprint shape is a square. The building is composed by a not heated reinforced concrete basement and three storeys in solid wood X-LAM panels. These floors contain the reception, bar, and some other functions on the ground floor. Twenty rooms are spread on the other two floors. The roof contains the solarium zone, photovoltaic and thermal panels and the thermal power plant which contains the ventilation systems with heat recovery. The building is equipped with summer-winter air conditioning, great openings accurate designed for adequately ventilation and daylight. All the windows are made of triple glass with a U value of 0.703 and protected by shading devices. These elements allow the use of night cooling, in order to improve the indoor thermal comfort and reduce the carbon footprint and energy consumption.

Source: <https://passivhausitalia.com>, [https://www.politesi.polimi.it/bitstream/10589/109230/1/nearly%20Zero-Energy%20Buildings%20\(nZEBs\).pdf](https://www.politesi.polimi.it/bitstream/10589/109230/1/nearly%20Zero-Energy%20Buildings%20(nZEBs).pdf), | Photo credit: -



# BIPV / BAPV

The BIPV system (Building Integrated Photovoltaics) is one of the viable technologies to improve building energy performance and to reduce environmental effects by on-site electricity generation with solar energy. This system is composed of photovoltaic cells that are capable of being integrated into the building skins such as roof or facade. There are two basic commercial PV module technologies available on the market today: thick crystal products, as crystalline silicon-based (c-Si); and thin-film products, as amorphous-based silicon (a-Si), cadmium telluride (CdTe) and copper indium gallium selenide (CIGS).



## Challenges

## Objectives

## Performances



Energy sustainability



Energy demand



Carbon impact



Energy produced from RES



Energy from RES on site



Low carbon material use



Greening



Energy efficiency



Temperature regulation



Local microclimate



UHI



Temperature surface/air



Outdoor thermal comfort



Shadow effect



Water management



Run off mitigation



Water scarcity



Water quality



Water retention



Water storage and reuse



Water treatment



Health and wellbeing



Comfort and life quality



Urban space quality



Green space



Space for socialization



Air quality



Walkability

## Other benefits



Reuse



Thermal insulation



Flexibility



Noise pollution



Safety



Weather protection

## Regulations & Standards

EN 50583-1, UNI 8290-1/2

## Strategies



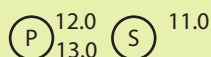
## Scale of application



## Space usage

Monofunctional  
Multifunctional

## S.D.G.



## Disadvantages

Slow development  
Weather dependent

# Energy consumption



## Energy from RES in site

Building retrofitting with BIPV represents an opportunity for improving both the energy efficiency by producing energy on site, and the architectural quality.

*Case study:* a building in a social house district in Catania (Italy, Csa zone) designed by K. Tange in the 1970s and built by IACP. It is composed of nine floors, main facades facing south and north, blind east and west fronts, balconies, flat roof, and double-glazing windows. To become a NZEB, some retrofit strategies were adopted such as the replacement of windows with new high-performing ones, the installation of reversible heat pumps and the integration of PV panels in the facades. Three kinds of PV panels as Monocrystalline Silicon (c-Si), Copper indium gallium selenide (CGIS) and Amorphous Silicon (a-Si) were tested virtually in three different locations (Catania, Milano and Roma). The results suggest that the best solution is c-Si modules with an average annual energy efficiency in between 12.5% and 13.5%, cover surface of 55% and annual electricity consumption of 3250 kWh, where the cooling demand is predominant [1].

## Low carbon material use

The BIPV system is composed of a significant technical component that is responsible for the growing global electricity demand, consequently for the impact of the CO<sub>2</sub> emissions.

*Case study:* BIPV installation in a car shelter and in a skylight with a total capacity of 20 kW, installed at Patras Science Park, in Peloponnese (Greece, csa zone).

The system includes skylights and a car shelter consisting of 22 and 66 panels, respectively.

The poly-crystalline technology is encapsulated in the frameless PV with a surface of 2.22 m and weighting 44.4 kg. The purpose is to quantify and analyse the environmental impacts using the LCA (cradle-to-grave) method. The results show that the BIPV system was 7.94 years for energy payback time, 3.78 for energy returned on energy invested and 6.46 g CO<sub>2</sub> per kWh for carbon cycle emissions [2].

## Energy efficiency

Integrated photovoltaic panels on the facade are essential to reduce energy consumption and provide indoor thermal comfort.

*Case study:* a typical residential building of the 70's located in Neuchâtel (Switzerland), composed of eleven-stories, 52 apartments and

5,263 m<sup>2</sup> of living floor area. Three strategies were adopted: "Conservation" (S1), "Renovation" (S2), and "Transformation" (S3). For all scenarios monocrystalline (sc-Si) technology of cells with an efficiency of 14% have been used. The target for the housing is 38 kWh/m<sup>2</sup>/year. This value is achieved by all scenarios, corresponding to a 53% saving on the heating demand. It means that the strategies produce respectively 75 (S1), 128 (S2) and 174 (S3) MWh/year [3].

Another interesting case [4].



## References

- [1] G. Evola and G. Margani, *Renovation of apartment blocks with BIPV: Energy and economic evaluation in temperate climate*, Energy and Buildings 130 (15 October 2016) Pages 794-810, <https://doi.org/10.1016/j.enbuild.2016.08.085>
- [2] D. N. Papadopoulos, C. N. Antonopoulos and V.G. Papadakis, *Environmental assessment of a BIPV system*, Advances in Energy Research 8 -Number 1(March 2022) pages 1-19, <https://doi.org/10.12989/eri.2022.8.1.001>
- [3] S. Aguacil, S. Lufkin and E. Rey, *Towards integrated design strategies for implementing bipv systems into urban renewal processes: first case study in Neuchâtel (Switzerland)*, Sustainable Built Environment (SBE) regional conference, Zurich (15 June 2016) [10.3218/3774-6\\_38](https://doi.org/10.3218/3774-6_38)
- [4] C. Theokli, C. Elia, M. Markou, C. Vassiliades, *Energy renovation of an existing building in Nicosia Cyprus and investigation of the passive contribution of a BIPV/T double facade system: A case-study*, Energy Reports 7 (November 2021) Pages 8522-8533, <https://doi.org/10.1016/j.egy.2021.03.025>



# BIPV/BAPV: best practice

## Project name

Smart Lab

## Climate zone

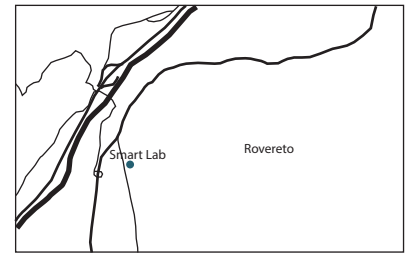
Cfb - Subtropical highland climate

## Construction year

2013

## Location

Rovereto Trentino, Italy



— River  
— Highway  
— Roads

## Integrated system

Thermal insulation

## Certification

LEED Silver

## Health & Comfort

The usage of BIPV as "solar shade" or combined with a ventilated facade prevents overheating in summer and heating in winter, greatly improving the quality of users' life.

## Energy consumption

9,072 kWh per year



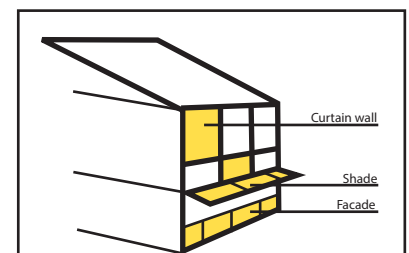
## Sustainability

It was estimated that the BIPV system can provide more than 30% of the building's electricity demand and can guarantee an effective thermal insulation. This system combined with the usage of recycled materials, the high quality of the technical-constructive strategies, are some of the measures adopted in Smart Lab with the prospect of green building and energy efficiency.



## How it works

Basically, they work as the PV panels but the photovoltaic could be integrated on the facade as shade, on the balcony, as curtain wall or as a wall. The BIPV system typically is composed by several components as PV modules, a charge controller to regulate the power into and out of the battery storage, and a power storage system that transform the utility grid in utility-interactive systems or, several batteries in stand-alone systems. In addition, the power conversion equipment is installed, and it include an inverter to convert the PV modules' DC output to AC compatible with the utility grid, a backup power supplies, and appropriate support and mounting hardware, wiring, and safety disconnects. It's necessary to highlight that panels efficiency decreases with the increase of transparency. The transparency male the PV not able to capture and convert sunlight into electricity.



## Description

The Smart Lab is a sociocultural meeting place for young people and associations managed by Cooperativa Sociale Smart Onlus. It is composed of two floors; on the ground floor there is a coworking space and a conference room; on the first floor there is a chillout corner, bookcrossing, internet point, etc. The facade has a strong visual impact that increases the architectural value of a building and its bearing structure is composed of metal uprights and crosspieces hiding the junction boxes and the cabling system. It is characterised by the BIPV plant that consists of 90 thin-film photovoltaic modules ProSol TF+ integrated to a ventilated facade system on the south facade of Smart Lab. The modules compose a semi-transparent layer made of micro-amorphous silicon cells, able to control the solar gain and to create an eco-friendly and aesthetically appealing surface, hiding the existing facade made of glazed and opaque.





# Solar panels



Building integrated solar thermal collectors (BIST) convert the sun's rays into thermal energy, in which the heat is conveyed into the air, liquid, or both. These kinds of systems are mainly used to produce low-temperature heat, for sanitary hot water and space heating support. The main feature is the total integration of the panels into the facade, playing a double role: aesthetic and functional. Compared to conventional panels, BIST collectors fit easily into the architectural design framework and guarantees a high degree of design freedom and realisation optimization because of the wide range of flexible size and height ratios.

## Challenges



Energy sustainability



Temperature regulation



Water management



Health and wellbeing

## Objectives



Energy demand



Carbon impact



Energy produced from RES



Energy from RES on site



Local microclimate



UHI



Run off mitigation



Water scarcity



Water quality



Comfort and life quality



Urban space quality



Indoor thermal comfort



Flexibility



Thermal insulation



Daylighting



Privacy



Noise pollution

## Performances



Low carbon material use



Greening



Energy efficiency



Temperature surface/air



Outdoor thermal comfort



Shadow effect



Water retention



Water storage and reuse



Water treatment



Green space



Space for socialization



Air quality



Walkability

## Regulations & Standards

EN 50583-1 and UNI 8290-1/2

## Strategies



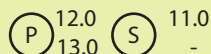
## Scale of application



## Space usage

Monofunctional  
Multifunctional

## S.D.G.



## Disadvantages

Slow development  
Weather dependent

# Energy consumption



## **Energy from RES on site**

Several studies show that solar panels can produce energy and satisfy the DHW demand, according to the location, geometry, used materials and climatic zone.

*Case study:* a typical multi-storey building located in Cagliari (Italy, zone). It is made up of five floors, balconies, and opaque walls. Using software simulation, the solar radiation was investigated. Consequently, 22 flat plate collectors on the south facade and 22 evacuated-tube solar collectors as active shading elements on the East-West facade, were placed. The results show that the panels could produce 100% of energy when the system is used for DHW only, and more than 60% when it is used also for space heating [1].



## **Low carbon material use**

The architectural integration of the solar system could increase the carbon footprint, according to the geometry, the climate zone and typology of materials used.

*Case study:* analysis of simulations of solar thermal facade (BSTF) in an Italian residential unit. The unit is characterised by an area of 40m<sup>2</sup>, facing south, daily DHW consumption equal to 200l/day. It was constructed with two distinct typologies of solar collectors: the first consists of a flat plate model (FPC), while the second configuration has an evacuated tube model (ETC). The results show that comparing the two systems, the value of greenhouse gases emitted during the production is equal to 1074 Kg CO<sub>2</sub> eq for the FPC and equal to 917 Kg CO<sub>2</sub> eq for the ETC system [2].



## **Energy efficiency**

Several studies show that the solar collector is one of the most effective strategies to save energy. Their efficiency depends mostly on the climate zone and the orientation, and the materials used.

*Case study :* analysis of air-based Flat-Plate solar thermal Collector (FPC) prototype for an office-use space. It is made up of an air channel, a back plate in aluminium sheet, and a steel absorber plate covered by black varnish. The results show that, in terms of energy savings, the highest energy saving is obtained in Naples with 9.1 MWh/y for the S-E oriented BISTS facade. Conversely, the lowest value is achieved by Freiburg with 4.5 MWh/y. In addition, considering the passive effects only, maximum savings equal to 7.5, 5.5 and 4.0 kWh/m<sup>2</sup>/y are achieved in Freiburg, Naples, and Almeria, respectively [3].

## **References**

- [1] A. Frattolillo, L. Canale, G. Ficco, C. C. Mastino and M. Dell'Isola, *Potential for Building Facade-Integrated Solar Thermal Collectors in a Highly Urbanized Context*, *Energies* 2020, 13(2021), 5801, <https://doi.org/10.3390/en13215801>
- [2] A. Gagliano, S. Aneli, F. Nocera, *Analysis of the performance of a building solar thermal facade (BSTF) for domestic hot water production*, *Renewable Energy* 142, November 2019, Pages 511-526, <https://doi.org/10.1016/j.renene.2019.04.102>
- [3] R. Agathokleous, G. Barone, A. Buonomano, C. Forzano, S.A. Kalogirou, A. Palombo, *Building facade integrated solar thermal collectors for air heating: experimentation, modelling and applications*, *Applied Energy* 239 (1 April 2019) Pages 658-679, <https://doi.org/10.1016/j.apenergy.2019.01.020>



# Solar panels: best practice

## Project name

CeRN building

## Climate zone

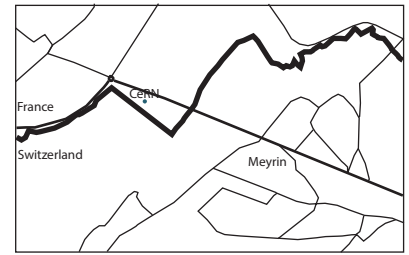
Cfb - Subtropical highland climate

## Construction year

2007

## Location

Bursins, Ginevra, Switzerland



## Integrated system

Roof solar collectors

## Certification

Minergie eco building

## Health & Comfort

The volumetry as well as the orientation of the openings reflects the specificities of this site and they can capture natural light and allow a correct natural ventilation to improve the quality of user's life.

## Energy consumption

11 MJ/m<sup>2</sup>/y  
Solar energy covers 40% of the heating demand



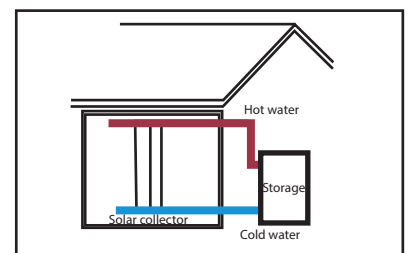
## Sustainability

The eco-friendly building is characterised by the of minimum grey energy content, the orientation and design of the building allows a good passive solar gain and natural lighting. In addition, the choice of materials aims to minimize environmental impacts, to use local resources and to limit transport and embodied energy. The main used materials are wood and concrete.



## How it works

Typically, the system is composed by the collectors that capture the sun's energy by heating a fluid contained within reinforced glass pipes. The pump and controller ensure the transfer fluid is circulated between the collectors and the water cylinder efficiently. A system control panel regulates the pump, providing information on the system's performance and highlighting any issues. The heat captured by the solar thermal collectors is pumped to a coil in the water cylinder. A solar thermal water cylinder has a dedicated coil that allows the heat from the collectors to be transferred as efficiently as possible.



## Description

The competition organised between 1999-2000, have been won by a studio based in Lausanne. This office presented a project that can combine sustainable development with particular sensitivity and strong technical interests. From the combination of socio-cultural issues related to the insertion of the building in the site and its operation for users, environmental aspects and economic constraints, the project has been realised. The CeRN building includes garages for vehicles, large storage spaces, technical rooms, as well as administrative premises. It's characterized by a south facade covered by thermal solar collectors for a solar facade surface of 590 m<sup>2</sup>, solar fraction of 97%, energy output of 288000 kWh/year obtained using 236x86x0.5 cm modules. In addition, a wood fired boiler installation covers heat needs from November to March, while solar thermal is sufficient to cover those for the rest of the year. The panels covered with a selective coating, can be installed without glass cover. The solar radiance reaches the absorber surface without being absorbed or reflected by a glass, therefore the effect of slope and azimuth are minimised.

Source: <https://www.osti.gov/etdeweb/servlets/purl/20948273#page=389>, | Photo credit: -

**SOLUTIONS  
ADD-ON**







# Productive facade system

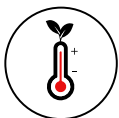
Productive facades (PFs), as flexible and multi-functional systems integrating photovoltaic (PV) and vertical farming (VF) systems, could contribute to transforming buildings and communities from consumers to producers. The positive aspect of this solution is that it can benefit from all the advantages of the PV system and vertical farming system at the same time.



## Challenges



Energy sustainability



Temperature regulation



Water management



Health and wellbeing

Other benefits

## Objectives



Energy demand



Carbon impact



Energy produced from RES



Energy from RES on site



Local microclimate



UHI



Run off mitigation



Water scarcity



Water quality



Water retention



Water storage and reuse



Water treatment



Comfort and life quality



Urban space quality



Green space



Space for socialization



Air quality



Walkability



Food production



Security/Safety



Reduce Heat gain



Flexibility



Indoor thermal and visual comfort

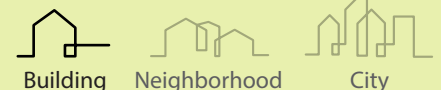


Biodiversity

## Regulations & Standards

## Strategies

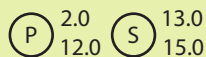
## Scale of application



## Space usage

Monofunctional  
Multifunctional

## S.D.G.



## Disadvantages

High maintenance costs  
Suitable only in some place and for some plants

# Energy consumption

# Temperature regulation



## Energy Sustainability RES on site

Productive facade system is one of the most complex solutions that can improve food production and energy efficiency. This capability mostly depends on the facade orientation, the quantity, typology and surface of modules installed.

*Case study:* an existing HDB public housing building in Singapore (Af zone) was considered.

Some facade arrangements for Window Facades (WF) and Balcony Facades (BF) were adopted. The PV cells of 2.8 m high, 1.8 m wide and 1.8 m deep were combined with different plants, to create four different scenarios. The results show that for a typical 4-room HDB unit with total façade dimension of 20 m in length, the total electricity generated by the shading PV modules could be as high as 1860 kWh (40% of the average annual electricity consumption). The electricity generated by the PV shading device represents between 40% (SBF) and 46% (SWF and EBF) of the electricity generated by the same PV module type and surface located on a rooftop without obstruction [1].



## Temperature surface/air

Productive facades are optimised for food production and electricity generation. Moreover, similarly to green walls, they have several environmental benefits such as reducing external surface temperature and air temperature [2]. However, specific tests in this regard have not been conducted yet.



## Greening

Productive facade system is one of the most complex solutions that can improve the energy efficiency and can improve the food production. This capability mostly depends on the facade orientation and the type of crops.

*Case study:* an existing HDB public housing buildings in Singapore (Af zone), was considered. Some facade arrangements for WF and BF were adopted. The PV cells of 2.8 m high, 1.8 m wide and 1.8 m deep were combined with different plants, to create four different scenarios. The results show that a facade of 20 m could enable each household to produce an estimated 35 to 66 kg of leafy vegetables. The number of products represents 55-103% of the average leafy vegetable's consumption of a 4-member household in Singapore (ca. 16 kg per year) [1].

## References

- [1] A. Tablada, V. Kosorić, H. Huang, I. K. Chaplin, S. Lau, C. Yuan and S. Siu-Yu Lau, *Design Optimization of Productive Facades: Integrating Photovoltaic and Farming Systems at the Tropical Technologies Laboratory*, Sustainability 2018, 10 (10), 3762, <https://doi.org/10.3390/su10103762>
- [2] Tablada, Abel, and Vesna Kosorić. "Vertical farming on facades: transforming building skins for urban food security." Rethinking Building Skins. Woodhead Publishing, 2022. 285-311.
- [3] Ling, Tzen-Ying, and Yi-Chang Chiang. "Well-being, health and urban coherence-advancing vertical greening approach toward resilience: A design practice consideration." Journal of cleaner production 182 (2018): 187-197.

## Water management

---



### **Water storage and reuse**

The productive facades are integrated with rainwater collection systems ensuring self-sufficiency. For example, the prototype developed by Tablada et al. (2022) collects, filters and stores rainwater from the roof and from the surroundings. The irrigation of the crops uses the electricity produced by the PV modules [2].

## Health and wellbeing

---



### **Green space**

Productive facades are experimentations to answer questions about food and energy production in densely urbanised areas. The practice of self-food production has positive effects and inhabitants' health and wellbeing, and improves their quality of life [3]. Moreover, the system is developed to improve public awareness and acceptance towards the use of Renewable Energy Sources in the facades.



# Productive facade system: best practice

## Project name

3D printed ceramic green wall

## Climate zone

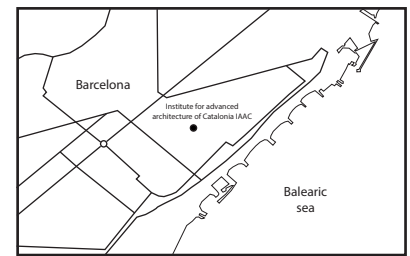
Csa - Hot-summer Mediterranean climate

## Construction year

2018

## Location

Prototype developed at Institute for advanced architecture of Catalonia IAAC, Barcelona, Spain



— River  
— Highway  
— Roads

## Responsive design

Computational design softwares were used to optimise topological variability of the pots for the growth of the plant species and to generate energy, through the parameters of height and opening angle. The system also needs to be adapted to the local conditions and to the plants used in terms of light and wind. Moreover, extreme heat, humidity and rain can affect the health of the plants and the biophotovoltaic system.

## Physical interface

The wall provides real-time information on energy generation through an immersive visualisation tool.



## Applications

The system can be implemented in public spaces, building skins, building rooftops and interior of buildings.

## Energy system

The system is self-sufficient and activates the irrigation system and the sensors.

## How it works

The productive facade systems have been developed by Tablada et al. (2018) through a prototype built at the National University of Singapore. The system integrates PV modules as shading devices and vertical farming on balconies. Applied to existing walls, the system produces energy and food for the inhabitants, as well as indoor visual and thermal comfort. Other applications combining food and energy production are currently under development, such as the 3d printed ceramic walls.



## Description

The 3D printed ceramic green wall is a prototype developed at the Institute for advanced architecture of catalonia IAAC. The wall system relies on a biophotovoltaic system (PBV) using the natural process of photosynthesis to produce energy. Through the energy from light, the plants consume carbon dioxide and water, and convert it into organic compounds. The latter contains bacteria releasing byproducts with electrons which can be collected as electricity using an electrode. The collection system was developed by Wey et al. (2015) at Cambridge. The types of plants used in the Barcelona prototype are native edible plants common in the Mediterranean climates for outdoor, and tropical low maintenance plants for indoor. The clay for the wall system was in stoneware which is suitable for printability, robust and absorbs low levels of water. Geometry and patterns were studied to optimise production, increase resistance and a good balance between stability and weight. The system has been standardised to allow installation into a secondary support structure and easy maintenance.

Source: [http://papers.cumincad.org/data/works/att/ecaade2020\\_456.pdf](http://papers.cumincad.org/data/works/att/ecaade2020_456.pdf); <https://iaac.net/project/cgv-cyber-green-voltaics/>; <https://iaac.net/iaac-at-the-smart-city-expo-world-congress/>, | Photo credit: IAACC



# Vertical farm

Vertical farming consists in a system of productive vegetation. It system often incorporates controlled-environment agriculture to optimize plant growth, and soilless farming techniques such as hydroponics, aquaponics, and aeroponics. The main advantages of this system are the minimal land use and the improvement of local flora and fauna. The key role is played by the site because the treatment system applied requires access to water, access to housing within the city to minimize the distance between staff and visitors, and a complex pipeline system. For these reasons, house vertical farming systems include buildings, containers, tunnels, etc.



## Challenges



Energy sustainability



Temperature regulation



Water management



Health and wellbeing

## Objectives



Energy demand



Carbon impact



Energy produced from RES



Energy from RES on site



Low carbon material use



Greening



Energy efficiency



Local microclimate



UHI



Temperature surface/air



Outdoor thermal comfort



Shadow effect



Run off mitigation



Water scarcity



Water quality



Water retention



Water storage and reuse



Water treatment



Comfort and life quality



Urban space quality



Green space



Space for socialization



Air quality



Walkability

## Other benefits



Indoor thermal comfort



Flexibility



Cooling effects



Food production



Privacy



Daylight

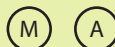
## Regulations & Standards



Space usage

Monofunctional  
Multifunctional

## Strategies



S.D.G.

P 2.0 - 3.0 S 13.0  
11.0 - 12.0 15.0

## Scale of application



Building



Neighborhood



City



Disadvantages

Suitable only in some place  
Suitable only for some kind of plants



# Energy consumption

---



## **Low carbon material use**

Several studies show that building integrated agriculture could be adopted to reduce the CO<sub>2</sub> emission. This solution allows to reduce the impact of transportation, energy, and water use.

*Case study:* the simulation of three different building-integrated hydroponic urban farms (farms 2,3,4) located in Lisbon (Portugal, csa zone) was adopted. These models are compared with the baseline case that consists of the current situation in Portugal. Tomato was selected as a crop, as Portugal is the 15th largest tomato producer worldwide (FAOSTAT, 2012). The other farms are different in construction properties, WWRs and climate control levels. The results show that the carbon footprint related to energy use, water use, and transportation is extremely high in urban farm 4 with 1.319 kg CO<sub>2</sub> eq/kg, followed by Urban farm 1 with 0.974 kg CO<sub>2</sub> eq/kg, urban farm 3 with 0.500 CO<sub>2</sub> eq/kg and urban farm 2 with 0.300 kg CO<sub>2</sub> eq/kg. All the farms are more sustainable than the baseline case whose carbon footprint is 1.042 kg CO<sub>2</sub> eq/kg [1].

## **References**

- [1] K. Benis, C. Reinhart and P.Ferrão, *Development of a simulation-based decision support workflow for the implementation of Building-Integrated Agriculture (BIA) in urban contexts*, Journal of Cleaner Production 147 (20 March 2017) Pages 589-602, <https://doi.org/10.1016/j.jclepro.2017.01.130>
- [2] G. Lages Barbosa, F. D. Almeida Gadelha, N. Kublik, A. Proctor, L. Reichelm, E. Weissinger, G. M. Wohlleb and R. U. Halden, *Comparison of Land, Water, and Energy Requirements of Lettuce Grown Using Hydroponic vs. Conventional Agricultural Methods*, International Journal of Environmental Research and Public Health 2015, 12(6), 6879-6891, <https://doi.org/10.3390/ijerph120606879>
- [4] Z. Tong, T. H. Whitlow, A. Landers and B. Flanne, *A case study of air quality above an urban roof top vegetable farm*, Environmental Pollution 208 - part A (January 2016) Pages 256-260, <https://doi.org/10.1016/j.envpol.2015.07.006>
- [3] WEBSITE - Grow It York, <https://growityork.org/> Access 27/10/2022

# Water management



## Water storage and reuse

Several studies show that the vertical farm could cause problems related to conventional agriculture such as the high and inefficient use of water and land, high concentrations of nutrients and pesticides in runoff, and soil degradation.

*Case study:* a comparison between hydroponics and conventional lettuce production in Yuma (Arizona, USA, BWh zone) was conducted. The hydroponics production is placed in a greenhouse of 815mq where temperature, supplemental artificial lighting, and water circulation pumps were controlled. Using data available from the National Agricultural Statistics Service (NASS), conventional lettuce production has a water demand of  $250 \pm 25$  L/kg/y. The results show that hydroponic lettuce production uses  $20 \pm 3.8$  L/kg/y of water. Comparing the two-situation, it emerged that the hydroponics system is more convenient in terms of water usage [2]. Another interesting case is [1].

# Health and wellbeing



## Space for socialization

“Grow It York” - a vertical, community farm at the heart of a vibrant container park in the city.

It's the name of an indoor urban community interest company that re-use shipping containers for local business in Piccadilly, York. They use an aeroponic strategy of growing crops as pea shoots, microgreens, and herbs, indoor without soil and pesticides and with less water. The farm was built to investigate the environmental positive impacts of healthy and bio food, but also to create a big community. The farm is open to the public that can visit containers and test the foods [3].



## Quality of air

Several studies show that the rooftop farm could strongly reduce the air pollution, because of the green components located above the ground level.

*Case study:* Brooklyn Grange Rooftop Farm in New York City (USA, zone) was considered. It is characterised by 40,000 square feet of vegetable and herb located on the roof of a seven-story building. Some sensors detected the PM2.5 concentration at street level and on the top of the building (at 26m above ground). The results show that the rooftop farm can reduce in average 7-33% of PM2.5. In addition, the quantity of heavy metal and pollution that can reach the roof farm is considerably less than the pollution received at street level fields [4].



# Vertical farm: best practice

## Project name

Plantagon World Food Building

## Climate zone

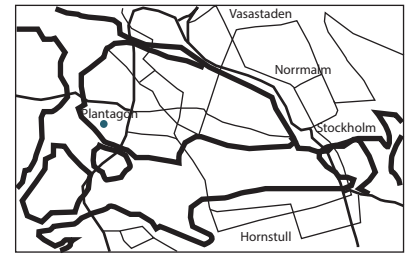
Cfb - Subtropical highland climate

## Construction year

2020

## Location

Linköping, Sweden



— River  
— Highway  
— Roads

## Integrated system

Biogas plant

## Certification

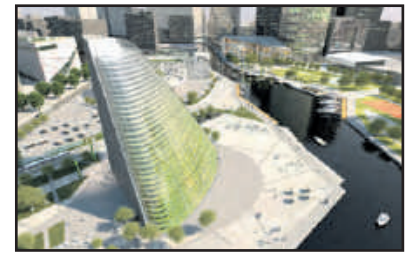
Swedish-American Chamber of Commerce Deloitte Green Award

## Water saved

13,000,000 gallons of water annually

## CO<sub>2</sub> saved

1100 tons of CO<sub>2</sub> emissions



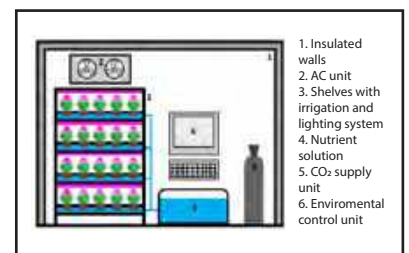
## Sustainability

The purpose is to build a system with the smallest environmental impact and the biggest food production, using the least amount of land and water. In addition, this system could have a low impact in terms of transportation and fertilisation, and a bigger impact in terms of sociable sustainability.

## How it works

Vertical farming is a complex system in which some kind of crops grow on top of each other in a controlled environmental. The plants usually cultivated are lettuce, chard, cabbage, rocket, kale and collard greens. The system is composed by multi-levels production shelves where plants are placed. Each shelf includes an irrigation and lighting system. Vertical farm doesn't use the traditional sunlight, consequently the farms' growing cycles aren't determined by seasonal variations in temperature and sunlight. They use the own light source for year-round photosynthesis through energy-efficient LED lights.

The irrigation system supplies water rich with nutrients directly to the plant's root. These systems are designed in a closed circuit, thus reducing water waste. In addition, the entire process with the temperature and ventilation systems are controlled by automatic systems control. Often use artificial intelligence or robots to assist in harvesting.



## Description

The Plantagon World Food Building located in Sweden, was designed as a vertical agriculture urban farm. The tower is characterised by 16-storey buildings of which two-thirds are allocated offices, local restaurants, and a market for selling vegetables and fruit, and the other third will include an indoor farm. In the greenhouse space, food grows using hydroponic farming – a method that involves submerging crops in nutrient-rich water. The production of approximately 550 tons of vegetables is possible by using a southern-sloped glass facade that allows the maximum amount of sun to pass into the farming areas. In addition, this building works symbiotically with its neighbourhood. The waste from the greenhouse is sent to the biogas plant located in the neighbourhood for composting, which will finally deliver energy that enables the plantation to operate. The recycling of resources usually regarded as waste is key to making sustainable and eco-friendly urban farming.

Source: <https://doi.org/10.3390/resources10110109>, <https://www.dezeen.com/>, <https://www.agritecture.com/> and <http://www.verticalfarms.com.au/advantagesvertical-farming>, | Photo credit: -



# Winter garden



Wintergardens are flexible spaces usually made of glass or with transparent plastic materials integrated or leaning against a building. The main advantages of this solution are collecting and conserving the light and heat of the sun and feeling of contact with nature. It can be used as garden, lab, living room, etc. In addition, it can be built as a building adhering to an existing house, or it can be isolated or embedded. To design a wintergarden, the following factors need to be taken into account: optimal orientation to maximize solar gain and dimensions of the space to heat. Even though it is not considered in the volume calculation, the wintergarden can increase the living space, provided that the bioclimatic greenhouses comply with municipal and / or regional regulations.

## Challenges

## Objectives

## Performances



Energy sustainability



Energy demand



Carbon impact



Energy produced from RES



Energy from RES on site



Low carbon material use



Greening



Energy efficiency



Temperature regulation



Local microclimate



UHI



Temperature surface/air



Outdoor thermal comfort



Shadow effect



Water management



Run off mitigation



Water scarcity



Water quality



Water retention



Water storage and reuse



Water treatment



Health and wellbeing



Comfort and life quality



Urban space quality



Green space



Space for socialization



Air quality



Walkability

## Other benefits



Indoor thermal comfort



Flexibility



Noise pollution



Food production



Artistic expression

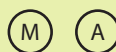


Daylight

## Regulations & Standards

TUE – DPR 380/2001 and Local law Trento 4/3/2008 n. 1

## Strategies



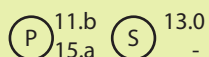
## Scale of application



## Space usage

Monofunctional  
Multifunctional

## S.D.G.



## Disadvantages

Low thermal insulation  
Wet weather

# Energy consumption

# Health and wellbeing



## Low carbon material use

Building retrofitting by enlarging flat areas with wintergardens improves the quality of the space but requires attention on the choice of materials to limit the carbon footprint. Several studies show that retrofitting prefabricated buildings generates lower emissions than demolition and construction, but each project requires a specific analysis.

*Case study:* revitalization projects of Tour Bois le Pretre and 530 logements in Paris and Bordeaux (Cfb) designed by Lacaton-Vassal studio. The rehabilitation of the facades through wintergardens reduced the carbon footprint by using prefabricated elements. Another study assessed carbon footprint of different configuration of retrofits with wintergardens, comparing the materials. According to their analysis, the best option is the one with cantilever balconies made of steel. This solution is 27% lower than stacked balconies with steel structure and 43% lower than stacked balconies with reinforced concrete. Thus, the use of disassembled panels of texture layers as finishing elements and prefabrication reduce carbon footprint [1].

## Energy efficiency

The energy efficiency of the wintergarden system depends on: orientation, climatic zone and materials used.

*Case study:* two apartments of a typical three-storey building in Sweden (Cfb). The 'middle apartment' is on the second floor and its space heating demand is about 61 kWh/(m<sup>2</sup>yr). The 'corner apartment' is on the last floor and its space heating demand is about 119 kWh/(m<sup>2</sup>yr). The study testes different passive solutions to retrofit the buildings, including a wintergarden characterised by single clear glazed window. The results show that the winter garden reduces the space heating demand by 30% in the middle apartment, and 18% in the corner apartment. In addition, the winter garden enhances thermal comfort without extra heating or cooling in living space [2].



## Green space

It's shown that there is a connection between green space and mental health. Several studies show that people who live in green urban areas feel less mental distress, less anxiety and depression. Comparing residents close to the green area to residents far from the green area, some differences have been shown. People that live in a greener area present better mental health and volunteer for sustainable improvement. In addition, new technologies allow the little green space as the greenhouse that could host different activities to improve the well-being such as the morning meditation, relating with the plants, and earthing. All these kinds of activities could reduce the stress and the anxiety mood [3].

## Space for socialization

Some projects have been designed to transform the greenhouses in space for socialisation and education such as the *Community Gardens* of Enrich Group and *Paspartù* project in Sicily. The team from Virginia Tech University, designed a socio-environmental garden that allows people to cultivate crops and interpersonal relationships. It's a greenhouse that looks like a traditional meeting room that contains an herb garden. The project purpose is to create a bridge between different generations and communities, to combine physical activity and mental benefits [4].



## Quality of air

The quality of air depends on several parameters such as the typology of crops, the position of the greenhouse, the orientation, the climate zone and the periods of the year.

*Case study:* a rooftop greenhouse laboratory (i-RTG Lab) located at Institute of Environmental Science and Technology (ICTA-UAB) at Bellaterra on the campus of the Universitat Autònoma de Barcelona (Catalonia, Spain, csa zone). The tomato production in the greenhouse was used for daily i-RTG indoor and outdoor aerobiological monitoring and testing or air quality. The results show that the pollen grains and fungal spores depend on the period, in particular the highest pollen grains were registered in the period from February to April with a total of 4924 pollen grains/m<sup>3</sup>. The highest fungal spores were registered in the same period and with an amount of 295,038 fungal spores/m<sup>3</sup> [5].



## References

- [1] K. Canaj, A. Mehmeti, V. Cantore and M. Todorović, *LCA of tomato greenhouse production using spatially differentiated life cycle impact assessment indicators: an Albanian case study*, Environmental Science and Pollution Research 27 (2020) Pag. 6960–6970, <https://doi.org/10.1016/j.job.2021.103713>
- [2] S. Gosztonyi, M. Stefanowicz, R. Bernardo and Å. Blomsterberg, *Multi-active façade for Swedish multi-family homes renovation: Evaluating the potentials of passive design measures*, Journal of Facade Design and Engineering, 5(1) (2020) 7–21, <https://doi.org/10.7480/jfde.2017.1.1425>
- [3] J. Barton and M. Rogerson, *The importance of greenspace for mental health*, Cambridge University Press (January 2018), <https://doi.org/10.1192/S2056474000002051>
- [5] M. Ercilla-Montserrat, R. Izquierdo, J. Belmonte, J. I. Montero, P. Muñoz, C. De Linares and J. Rieradevall, *Building-integrated agriculture: A first assessment of aerobiological air quality in rooftop greenhouses (i-RTGs)*, Science of The Total Environment 598 (November 2017) Pages 109-120, <https://doi.org/10.1016/j.scitotenv.2017.04.099>
- [4] WEBSITE - Cabin public gardens can be hubs for healthy food and socializing, <https://en.futuroprossimo.it> Access 26/10/2022





# Winter garden: best practice

## Project name

Crowne Plaza Hotel Verona

## Climate zone

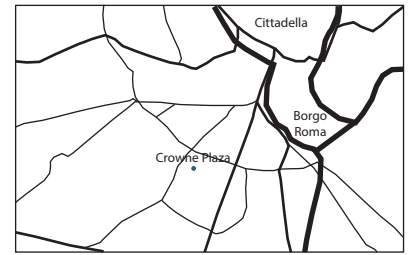
Cfb - Subtropical highland climate

## Construction year

2016

## Location

Verona, Veneto, Italy



— River  
— Highway  
— Roads

## Integrated system

Heating/cooling system  
Lighting system

## Certification

-

## Health & Comfort

The presence of all the systems combined with some other services as the wi-fi, the special lighting and the presence of all devices for hosting an event, enhance the comfort of users.

## Energy consumption

-



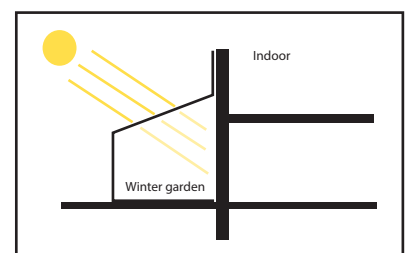
## Sustainability

The winter garden is usually oriented to the south to capture more solar radiation, reduce heating needs in wintert. In addition, it can improve social sustainability.



## How it works

The winter garden consists in a house's extension that creates a connection between the surroundings and the house. In the above mentioned best practice, the wintergarden also hosts several types of indoor plants (e.g pansies, coronilla, hellebores, camellia, ilex, cornus, sarcococca). The big openings of usually high-performance glazing or plaster materials absorb a lot of sunlight. Moreover, the system creates the condition for natural ventilation to avoid humidity and mold problems. The natural operation principles are: capture of solar rays, greenhouse effect, thermal storage by radiation, health distribution by radiation, convection, and heat air flows transport. According to the system, the wintergarden can be passive, semi-passive or active.



## Description

The Crowne Plaza winter garden is directly linked to the hotel, and it is characterised by tropical plants, floor area of 600m<sup>2</sup>, and a combination of natural and artificial lighting. This structure consists of seven transversal arches hinge-connected to the concrete foundations. All arches have different shapes to generate the volume of an incomplete egg. The seven arches are connected with 11 longitudinal profiles, which are curved, bending, and stiff, and that run above the arches as well as connecting all arches to the technical installation building. The steel profiles also act as bearing profiles for the Ethylene tetrafluoroethylene (ETFE) cushions, always used for botanical gardens, zoos, etc. The winter garden cushions were replaced with new trile layers materials with g value of 0.24, to enhance thermal comfort. The external layer is made by silver, while the inner one has a star's patterns.

Source:file:///C:/Users/Amministratore/Desktop/B978-1-78242-233-4.00021-8.pdf, wintergardenverona.it and <https://www.macotechnology.com/>, | Photo credit: -

**SOLUTIONS  
OPEN SPACES**





# Pervious pavement

Permeable paving surfaces allow water to pass through them into the soil and filter pollutants from stormwater. They can be either made of porous materials or nonporous blocks spaced to let water flowing. The former can be made of several different materials (e.g. pervious concrete, porous asphalt, paving stones). The latter can be with as grass-concrete pavers, open-cell concrete blocks, or blocks laid in open patterns, allowing plants to grow between them and rainwater to penetrate the soil. Semi-pervious paving materials such as wood chips, shells, gravel or stone aggregate allow rainwater to infiltrate but cannot support heavy loads. Permeable paving systems can be used for roads, paths and parking lots and residential sidewalks and driveways.



## Challenges

## Objectives

## Performances



Energy sustainability



Energy demand



Carbon impact



Energy produced from RES



Energy from RES on site



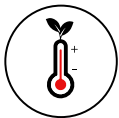
Low carbon material use



Greening



Energy efficiency



Temperature regulation



Local microclimate



UHI



Temperature surface/air



Outdoor thermal comfort



Shadow effect



Water management



Run off mitigation



Water scarcity



Water quality



Water retention



Water storage and reuse



Water treatment



Health and wellbeing



Comfort and life quality



Urban space quality



Green space



Space for socialization



Air quality



Walkability

## Other benefits



Biodiversity



Flexibility



Integration



Safety



Artistic expression



Cooling effects

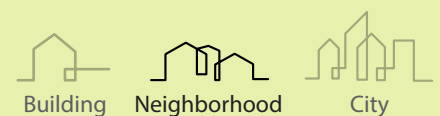
## Regulations & Standards

Legge Prov. 4/03/ 2008, n. 1, art.97  
Decreto 11/01/2017 – CAM 2.2.3

## Strategies



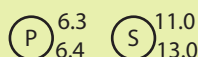
## Scale of application



## Space usage

Monofunctional  
Multifunctional

## S.D.G.



## Disadvantages

No buffering capacity  
Clogged with sediment

# Energy consumption

# Temperature regulation



## Low carbon material use

Several studies show that the pavement LCA could be influenced by the analysis period, the discount rate and the design life.

*Case study:* the improvement project of HWY 4 Kennedy Hill Safety Improvements, located on Vancouver Island (British Columbia, zone), was considered. This highway is characterised by a length of 1.5 km, two 3.6-m lanes and it is alongside an important spawning habitat and the largest freshwater body on Vancouver Island. Four pavements have been tested, of which 2 open graded friction course (OGFC) and 2 hot-mixed asphalt (HMA), different in lifespan and thickness. The results show that, using the LCA method, the most quantity of carbon emissions are produced by the OGFC pavement with a lifespan of 20 years and a thickness of 20mm, with a footprint of 3217 MgCO<sub>2</sub>-eq. Conversely, the least impacting floor is HMA pavement with 30 years of life design and 210mm of thickness, with a footprint of 2695 MgCO<sub>2</sub>-eq. [1].



## Temperature surface/air

The surface temperature of permeable pavements strongly depends on the moisture of the surface layer and on the climate zone.

*Case study:* comparison between three pavement typologies located in the suburbs of Guangzhou (China, zone). The permeable paving materials include ceramic permeable brick (CB) and open-graded permeable concrete (PC) made of a single-size aggregate. A dense concrete (DC) with a water-cement ratio of 0.40 and an aggregate-cement ratio of 3:1, was used as a reference. The results show that the surface temperature of CB in wet conditions is 10 °C lower after sprinkling compared to 5 °C for PC in wet conditions [2].



## Outdoor thermal comfort

Several studies show that the UTCI factor is influenced by a lot of different parameters such as relative humidity, air humidity, orientation, wind speed, and shade effect. The most important parameters are radiant temperature and air temperature.

*Case study:* a wetting optimization of a double-layer porous pavement during an extreme heat wave located in Zurich (Switzerland, zone) through a CFD model. The model is composed of the top finer layer of low porosity (10%) porous pavement material and thickness of 7.5 cm, while the bottom 7.5 cm of the pavement consists of a coarser layer, higher porosity (30%). The pedestrian thermal comfort is evaluated by the UTCI, which is calculated using local values for air temperature, relative humidity, wind speed and mean radiant temperature. The results show that with high wetting fluxes, the reduction in the UTCI remains at 2°C during a large part of the afternoon. Finally, it reaches above 1°C even during the second day with a wetting flux of 3.5mm/h [3].

## References

- [1] A. Hung, L. Y. Li and O. Sweit, *Evaluation of permeable highway pavements via an integrated life-cycle model*, Journal of Cleaner Production 314 (10 September 2021) 128043, <https://doi.org/10.1016/j.jclepro.2021.128043>
- [2] J. Wang, Q. Meng, K. Tan, L. Zhang and Y. Zhang, *Experimental investigation on the influence of evaporative cooling of permeable pavements on outdoor thermal environment*, Building and Environment 140 (August 2018) Pages 184-193, <https://doi.org/10.1016/j.buildenv.2018.05.033>
- [3] A. Kulibay, A. Ferrari, D. Derome and J. Carmeliet, *Smart wetting of permeable pavements as an evaporative-cooling measure for improving the urban climate during heat waves*, Journal of Building Physics 45 (1),(July 2021), Pages 36-66, <https://doi.org/10.1177/1744259120968586>
- [4] S. S. Cipolla, M. Maglionico and I. Stojkov, *Experimental Infiltration Tests on Existing Permeable Pavement Surfaces*, Soil Air Water Volume44, Issue1 (January 2016) Pages 89-95, <https://doi.org/10.1002/clen.201400550>



# Water management

---



## **Water retention**

An important index to evaluate the infiltration of the water to the soil, is the SIR – soil infiltration rate. Generally, higher SIR means larger permeable areas.

*Case study:* eight permeable parking lots located in Rimini (Italy, cfa zone). Each parking lot have different characteristics. Site 1 has a capacity for 50 cars and consists of concrete grid pavers (CGP) with a mixture of sand (70%), soil (30%), and 40% grass. Site 2 has a total capacity of 30 cars and is composed of honeycomb plastic grids (PG) filled with a mixture of soil. Site 3 is a park area for 80 cars and it is a CGPs filled with a mixture of gravel and sand. Site 4 has a surface of 750 m<sup>2</sup> composed of concrete grids filled with gravel. Site 5 is a PG paver with 95% open surface filled with soil. Site 6 with a total surface of 1950 m<sup>2</sup> and it is composed of 10% of sand. Sites 7 and 8 were CGPs with 40% of voids and a 22 cm thick drainage layer between the surface layer and the subgrade. The results show that the worst scenario is represented by site 6 with 11% of voids and 123mm/h permeability value. Conversely, Sites 3 and 4 are characterised by the highest average SIR of 10 574 and 20 137 mm/h, respectively [4].



## **Water treatment**

Several studies show that the permeable pavements can highly improve the quality of water using their capacity to capture heavy metals.

*Case study:* a lab-scale test bed has been tested by Turco et al. (2020). It consists of a plexiglas container of 59 x 459 x 41 cm with a circular outlet in the centre of the bottom, a total volume of 143.000cm<sup>3</sup>, and three layers - wear layer, bedding layer and sub-base layer. The concentrated chemical elements have been used to prepare synthetic stormwater, specifically 5–15 mg/L of dissolved Cu using Cu (SO)<sub>4</sub>, and 6–15 mg/L of Zn using Zn(CH<sub>3</sub>COO)<sub>2</sub> · 2H<sub>2</sub>O). The results show that the Cu removal rate is higher than the Zn removal rate. Specifically, the Cu removal rate is in a range of 85% to 92%, while the Zn one is from 65% to 82% [5].



# Pervious pavements: best practice

## Project name

Simulation of pre and post implementation of pervious surfaces

## Climate zone

Csa - Hot - summer Mediterranean climate

## Construction year

2017

## Location

Avola, Sicilia, Italy

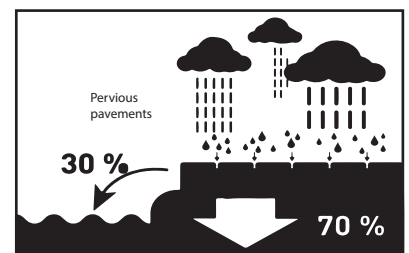
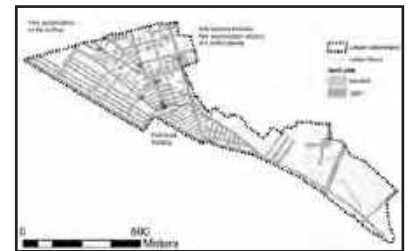


## Pervious material

Manning's roughness coefficient  $n=0.015$   
Thickness 150 mm  
Permeability 300 mm/h  
Storage height 300 mm

## Surface run-off

19.46 mm in 2 years  
28.86 mm in 5 years  
34.26 mm in 10 years



## How it works

Permeable paving is made from porous stones. When it rains, the water seeps into the stone and drains into the ground. The water percolates, such as it would in a coffee pot, through the paving into a layer of gravel that acts as a natural filter, cleansing the water of any pollutants. Sometime permeable pavers are not exactly permeable. In fact, rainwater does not filter through the pavers, but they have gaps between them that allow water to pass through to the various layers underneath. In both cases, the clean water can conduce to the reservoir when it could be storage.

## Description

The case study area is located in Avola, and it is characterised by the almost uniform morphology, with an elevation varying from 45 m to 10 m above sea level and an average slope value of about 3%. The site has a size of 39.5 ha and includes an urban fabric composed by different building types. To evaluate the appropriate strategies, hydrologic - hydraulic analysis, using simulation and modelling tools, have been conducted. A comparison between two types of SUDS measures, permeable pavements and green roofs have been investigated. The permeable pavements are in existing public spaces, and they include 150 units of 15 m<sup>2</sup>. Conversely, the green roof was located in a portion of a private building. It is characterised by roughness coefficient ( $n=0.1 \text{ s/m}^{1/3}$ ), surface slope (2.5%), thickness (87.5 mm), porosity (0.5), drainage mat thickness (3 mm). In addition, it covers just 20% of the surface.



# Cool pavement

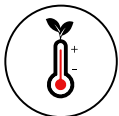
Cool pavement is a surface that reduce surface temperatures and the amount of heat absorbed by using cool materials. These materials increase albedo, thereby reflecting shortwave radiation out of the atmosphere. Pavement reflectance is enhanced by using reflective aggregate, reflective or clear binder or reflective surface coating. These materials could be used for new structures or for the existing ones. Cool pavements could be used for low-traffic areas, such as side-walks, trails, parking lots and streets. In addition, it could be combined with permeable pavements, and vegetated pavements, to increase the albedo.



## Challenges



Energy sustainability



Temperature regulation



Water management



Health and wellbeing

Other benefits

## Objectives



Energy demand



Carbon impact



Energy produced from RES



Energy from RES on site



Low carbon material use



Greening



Energy efficiency



Local microclimate



UHI



Temperature surface/air



Outdoor thermal comfort



Shadow effect



Run off mitigation



Water scarcity



Water quality



Water retention



Water storage and reuse



Water treatment



Comfort and life quality



Urban space quality



Green space



Space for socialization



Air quality



Walkability



Indoor thermal comfort



Flexibility



Noise pollution



Safety



Artistic expression

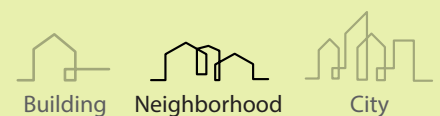
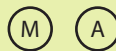


Lighting costs

## Regulations & Standards

## Strategies

## Scale of application



## Space usage

## S.D.G.

## Disadvantages

Monofunctional  
Multifunctional



Brightness  
Difficult installation

# Energy consumption

# Temperature regulation



## Low carbon material use

Cool pavements can decrease energy demand and Global Warming Potential during their lifespan. Their performance depends on emissivity factor, albedo, climate zone and context.

*Case study:* in-field experimental investigation of five paving fields in University of Perugia (Italy, zone). The five pavements consist of a conventional asphalt (AR), a light-colored concrete (CR) and two different versions of the presented resin binder with and without TiO<sub>2</sub> (RTB and RB, respectively). Only white grains (GR) were considered as a reference scenario. A cradle-to-gate assessment was performed for a time frame of 100 years. The results show that the best solution with lower carbon emissions is the AR with 0.672 kgCO<sub>2</sub>eq, followed by the RB with 0.967 kgCO<sub>2</sub>eq. The worst case is represented by CR with 2.716 kgCO<sub>2</sub>eq. [1].



## Temperature surface/air

Several studies show that high solar reflectivity and high infrared emissivity could reduce the convection of heat from pavement to the atmosphere, consequently decreasing air temperature.

*Case study:* simulations of high-density residential district in Thessaloniki (Greece, csa zone). Four different scenarios - A, B, C, D - were analysed. Case A represents the current situation; case B consists in cool asphalt and concrete pavements, having design albedo values of 0.40 and 0.70 respectively; case C corresponds to a first ageing scenario, and case D corresponds to a second, less optimistic ageing scenario. The results show that the best case is case B with a surface temperature reduction of 5.0 °C-7.0 °C and 6.0 °C-9.0 °C for the all the exposed parts of the asphalt streets and pavements respectively [3].



## Energy efficiency

The application of high albedo pavements increases the solar gains transmitted into the building unit, reducing energy demands.

*Case study:* a high-density residential neighbourhood located in Thessaloniki (Greece, csa zone). The site extends to 40000 m<sup>2</sup> and contains six blocks of residential buildings and open spaces including street canyons and courtyards of irregular shapes. Some scenarios have been simulated: the base case (BC), with ground surfaces covered by conventional asphalt and concrete pavements; the design cool materials scenario (Des.CM-) that includes cool asphalt (albedo 0.40) and cool concrete pavements (albedo 0.70); a cool materials scenario (Aged.CM-Aged). The high albedo asphalt and pavements have lost their initial reflectivity by 40% and 15% respectively. The results show that comparing the Des. CM with the BC scenarios, the energy saving for cooling is -0.5% and for heating is 0.8%. Different results are obtained comparing the Aged. CM-Aged with the BC the energy saving for cooling is 0.0% and for heating is 0.7% [2].



## Outdoor thermal comfort

The universal thermal climate index (UTCI) is one of the parameters that could be used to evaluate the thermal comfort in open space. The effects of the solution on thermal comfort depend on the type of cool material and on the urban fabric.

*Case study:* comparison between the actual scenario and cool pavements scenario in the ZIP district of Padua (Italy). Its development started in 1946 and now it covers an area of over 11 km<sup>2</sup>. It hosts more than 1300 industries, and it has a regular urban geometry composed of large road axes for the transit of vehicles. The Cool Pavement Scenario has an extension of 73,200 m<sup>2</sup> and it is composed of white topping, pervious concrete, colored asphalt and permeable interlocking concrete blocks. The results show that the colored asphalt with an albedo of 0.27, produced a reduction of UTCI up to 0.3 °C [4].

## References

- [1] I. Kousis, C. Fabiani and A. L. Pisello, *Could a bio-resin and transparent pavement improve the urban environment? An in field thermo-optical investigation and life-cycle assessment*, Sustainable Cities and Society 79 (April 2022) 103597, <https://doi.org/10.1016/j.scs.2021.103597>
- [2] S. Tsoka, K. Tsikaloudaki and T. Theodosiou, *Coupling a Building Energy Simulation Tool with a Microclimate Model to Assess the Impact of Cool Pavements on the Building's Energy Performance Application in a Dense Residential Area*, Sustainability 11(9), 2019, 2519, <https://doi.org/10.3390/su11092519>
- [3] S. Tsoka, T. Theodosiou, K. Tsikaloudaki and F. Flourentzou, *Modeling the performance of cool pavements and the effect of their aging on outdoor surface and air temperatures*, Sustainable Cities and Society 42 (October 2018) Pages 276-288, <https://doi.org/10.1016/j.scs.2018.07.016>
- [4] S. Croce, Elisa D'Agnolo, M. Caini and R. Paparella, *The Use of Cool Pavements for the Regeneration of Industrial Districts*, Sustainability 13(11)- (2021) 6322, <https://doi.org/10.3390/su13116322>



# Cool pavements: best practice

## Project name

Flaminio district

## Climate zone

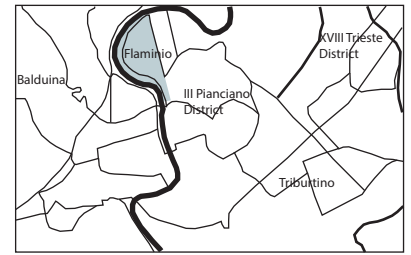
Csa - Hot - summer Mediterranean climate

## Construction year

2017

## Location

Rome, Lazio, Italy



## Cool material

Thickness asphalt of 0.01 m,  
Density of 1500 kg/m<sup>3</sup>,  
Thermal capacity of 6.50 kJ/khK,  
Thermal conductivity of 0.50 W/mK

## Air temperature

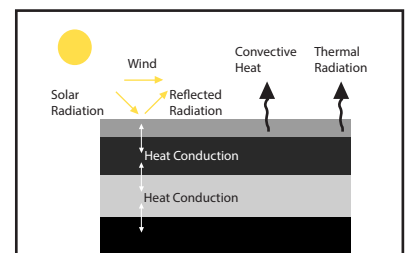
The 3D has been recreated and some simulations have been conducted using ENVI-met. The results show that, by increasing the asphalt albedo from 0.11 to 0.40 – 0.65 the air temperature decreases up to 1°C – 3°C.



## How it works

The roofs and pavements that cover around 60% of a city and absorb 80% of sunlight, are among the biggest contributors to the UHI. To evaluate how "cool" a specific material is, it's necessary to measure solar reflectance or albedo, thermal emittance, and the solar reflectance index. The most important is the solar reflectance, which is the percentage of solar energy reflected by the surface. These parameters are significant for surface temperatures; changing only albedo can significantly alter surface temperatures. Conventional paving materials such as asphalt and concrete have solar reflectance of 5% to 40%, which means they absorb 95% to 60% of energy. In alternative, cool-coloured coatings that reflect about 50% of sunlight could be used.

Another important factor is the time. All materials that are exposed to the atmosphere change the solar reflectance of pavement over time. For example, as cement concrete pavement ages, it tends to get darker with tire and grease stains, for these reasons the solar reflectance index changes from 30-50% to 20-35%. Conversely, the asphalt concrete lightens because of more aggregate is exposed through wear, for these reasons the solar reflectance index changes from 5% to 10-20%.



## Description

The Flaminio district is an area of about 0.218 km<sup>2</sup>. It is located in the north of the city of Rome and north-west of the Tiber River. It is characterised by the presence of historical buildings, condominiums about 70's, sheds for industrial use and some modern buildings. The area of 735000 m<sup>2</sup> is characterised by vegetation along the streets and around the river. An alcometer was used to evaluate the solar surface reflectance. The results show that the roof consists of bituminous materials and measure an albedo of 0.10, the wall albedo in a range of 0.21 and 0.85, and the asphalt has an albedo of 0.11. It's shown that the high albedo that allows the low absorption of solar radiation and high infrared emission, could mitigate the UHI effects.





# Pocket garden

Pocket or garden parks are publicly accessible and compact green areas around and between buildings. They could be vegetated by ornamental trees, grass, other types of plants - perennial, annual plants, herbaceous – combined with outdoor furniture and decorations. Because of their size, they usually do not provide opportunities for great physical activities, but the area is designed for playing, for relaxing, meeting friends, and some other outdoor activities. Pocket gardens provide opportunities to create small but important public spaces for people in their own neighbourhoods.



## Challenges

## Objectives

## Performances



Energy sustainability



Energy demand



Carbon impact



Energy produced from RES



Energy from RES on site



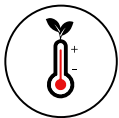
Low carbon material use



Greening



Energy efficiency



Temperature regulation



Local microclimate



UHI



Temperature surface/air



Outdoor thermal comfort



Shadow effect



Water management



Run off mitigation



Water scarcity



Water quality



Water retention



Water storage and reuse



Water treatment



Health and wellbeing



Comfort and life quality



Urban space quality



Green space



Space for socialization



Air quality



Walkability

Other benefits



Biodiversity



Food production



Heat gain



Privacy



Indoor thermal comfort



Flexibility

## Regulations & Standards

## Strategies

## Scale of application



Space usage

Monofunctional  
Multifunctional



S.D.G.

P 11.0 S 6.0  
P 15.0 S 13.0



Disadvantages

Increased maintenance  
Limited plant sizes



# Temperature regulation



## Temperature surface/air

The air temperature could change according to the presence of the pocket garden, specifically it depends on the typology of plants, soil and area's size.

*Case study:* 11 pocket gardens located in Victoria (Australia). These eleven areas contain 655 plants of 122 species across 80 genera divided in  $1 \times 1$  m<sup>2</sup> transects placed every 5 m across the garden. All gardens had a minimum of eight  $1 \times 1$  m<sup>2</sup>, and proportionally a  $1 \times 1$  m<sup>2</sup> was added for every additional 500 m<sup>2</sup> for gardens. The study shows that daily temperatures are in between 22.2 - 23.2 °C at the garden scale and 21.2 - 26.1 °C at the plot scale. The temperature variability values ranged from 22.4 to 31.9 °C at the garden scale and 19.8 to 35.4 °C at the plot scale. In addition, mean temperature is lower in gardens with higher impervious surfaces surrounding them (garden-scale temperatures), and mean temperatures are lower in larger gardens [1].



## Outdoor thermal comfort

Outdoor thermal comfort in pocket gardens can be increased by trees.

*Case study:* two within the most busy main street of Erzurum (Turkey, dfb zone). Two different scenarios were considered: the first one consists of the addition of deciduous tree species on the street, the second one includes parking area within the deciduous trees. Both streets are in the same direction and are positioned as a continuation of each other. The results show that the first street has the SVF value low, while in the second street the SVF value is higher. In addition, the index of agreement (d) for street 1 is 0.91 and 0.99 for winter and summer, respectively. The index of agreement (d) for street 2 is 0.88 and 0.99 for winter and summer, respectively [2].

## References

- [1] M. H. Egerer, B. B. Lin, C. G. Threlfall, D. Kendal, *Temperature variability influences urban garden plant richness and gardener water use behavior, but not planting decisions*, Science of The Total Environment 646 (1 January 2019) Pages 111-120, <https://doi.org/10.1016/j.scitotenv.2018.07.270>
- [2] S. Yilmaz, B. E. Mutlu, A. Aksu, E. Mutlu and A. Qaid, *Street design scenarios using vegetation for sustainable thermal comfort in Erzurum*, Environmental Science and Pollution Research 28 (2021), pages 3672–3693, <https://doi.org/10.1007/s11356-020-10555-z>
- [3] M. Gittleman, C. J. Q. Farmer, P. Kremer and T. Mc Phearson, *Estimating stormwater runoff for community gardens in New York City*, Urban Ecosyst (2017) 20:129–139, <https://doi.org/10.1007/s11252-016-0575-8>
- [4] B. B. Lin and M. H. Egerer, *Global social and environmental change drives the management and delivery of ecosystem services from urban gardens: a case study from Central Coast*, California, Global Environmental Change 60 (January 2020) 102006, <https://doi.org/10.1016/j.gloenvcha.2019.102006>
- [5] J. Spilková, *Producing space, cultivating community: the story of Prague's new community gardens*, Agriculture and Human Values 34

# Water management



## Water retention

Pocket gardens can provide important benefits for stormwater runoff mitigation in comparison to other land uses, due to their soil amending and composting functions.

*Case study:* 529 gardens located in New York City (USA, cfa zone). They are characterized by 83% of green space, 16% paved, and 1% bare soil, for a total of about 49ha. The results show a higher percentage of water absorbed during the 3.8 cm rain event than during the 12.7 cm rain event across methods. Specifically, for each storm level, respectively, about 2.3 mm and about 4.1 cm of water would become runoff for each square inch of the garden [3].



## Water treatment

According to the typology of plants and the position of green area, the property of the soil and the nutrients change.

*Case study:* two suburban lots, two semi urban lots and two urban lots located in Leipzig (Germany). A total of 36 plots, of which six vacant plots, 12 medium - intensity plots and 12 high-intensity plots with a total area of 0.75 ha in allotment estates, and 6 adjacent community gardens. These allotment estates host up to 22% of all shrubs and small trees of the built-up area of Leipzig. The results show that water content was significantly influenced by the vegetation patch type ( $p = 0.0038$ ). Edible areas showed the highest values for soil water content, while lawn showed the lowest values. The location of the gardens in the city had a significant effect on soil pH ( $p = 0.019$ ) and a marginally significant effect on soil water content ( $p = 0.055$ ) in allotment gardens. In both cases the highest values were found in semi-urban gardens, the lowest values in suburban gardens [7].

# Health and wellbeing



## Green space

Several studies show that pocket gardens increase the amount of green urban areas and provide several ecosystem services.

*Case study:* 20 gardens have been studied between 2015 and 2018 during the summer seasons in California Central Coast region. The gardens studied are 405–8134 m<sup>2</sup> in size, 2–39 years in age, and are surrounded by a mix of natural, agricultural, open green space, etc. They have been selected because they were all managed in an allotment where households cultivate individual plots within the garden or because well supported by local. They represent an important resource because they serve between 5 and 92 different gardeners who garden for a wide variety of reasons including food production but also quality family time, and social cohesion. In addition, some survey questionnaires show that gardeners represent a diverse range of family sizes, education and salary levels [4].



## Space for socialization

Eleven of the sixteen larger community garden in Prague open for participation to the people in their neighbourhood, were identified as listed on the map published by KOKOZA (<http://www.kokoza.cz>). The data collected by semi-structured interviews with the managers of the gardens, show that fall the gardens were formed through bottom up approaches, either by initiative of the gardeners themselves or in many cases of one or two activists who began a garden. Most of the gardeners state that the impulse of the initiatives was the improvement of urban quality, by regenerating unused or abandoned areas and by creating space for social connections [5].



## Walkability

Several studies show that pocket gardens increase the neighborhood walkability and improve healthy behaviours, such as physical activity as well as reducing depressive symptoms. Accessibility is key to increase gardening for elderly. Gardening has an array of positive influences on many aspects of the life of elderly, including physical, nutritional, social, and psychological. In addition, it has been shown that walking, gardening, and yard work are some of the most popular forms of physical activity in older adults. A secondary analysis of the LIFE-P study, which examined 70–89-year-old adults at risk for mobility disability, determined that those who lived in less compact neighborhoods spent more time performing heavy gardening compared with those in more compact [6].

(2017) pages887–897, <https://doi.org/10.1007/s10460-017-9782-z>

[6] A. Klann, L. Vu, M. Ewing, M. Fenton and R. Pojednic, *Translating Urban Walkability Initiatives for Older Adults in Rural and Under-Resourced Communities*, International Journal of Environmental Research and Public Health 16(17), (2019) 3041, <https://doi.org/10.3390/ijerph16173041>

[7] I. Cabral, J. Keim, R. Engelmann, R. Kraemer, J. Siebert and A. Bonn, *Ecosystem services of allotment and community gardens: A Leipzig, Germany case study*, Urban Forestry & Urban Greening 23 (April 2017) Pages 44-53, <https://doi.org/10.1016/j.ufug.2017.02.008>



# Pocket garden: best practice

## Project name

Municipal community gardens in the metropolitan area of Milan.

## Construction year

2016

## Climate zone

Cfb - Temperate oceanic climate or subtropical highland climate

## Location

Milan, Lombardy, Italy



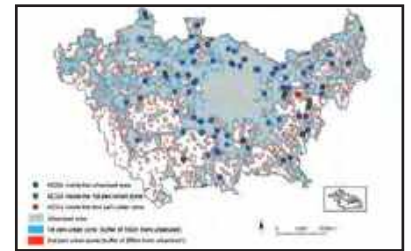
— River  
— Highway  
— Roads

## Health and well-being

Most MCGs are surrounded by a prevalent urbanized landscape, while the MCGs in agricultural areas are quite distant from the city of Milano. This confirms the role that the MCGs have to allow, in an urban environment, easy access to and contact with nature.

## Space for socialization

This data confirm that the municipality usually locate MCGs near urbanized areas in order to ensure a better accessibility, as should be for all social services.



## How it works

Pocket gardens are a kind of public gardens which haven't been included in the original project of an urban design, but they have been created subsequently on the basis of the initiative of free citizens, or as a result of a choice from the public administration. Pocket gardens are created within already existing blocks, for this reason the most peculiar characteristic is to be able to "slip" usually in undeveloped vacant lots, lots of demolished buildings or abandoned spaces. According to the context, the pocket garden contains typology of plants, urban furniture and some other accessory.



## Description

The study area is within the Metropolitan City of Milan which includes a total of 133 municipalities in a total area of about 1400 km<sup>2</sup> (55% agricultural, 36% urban, 8% forest and semi natural, 1% wetlands and water bodies). The analysis includes the definition and quantification of municipal community gardens (MCGs). The process is composed of several steps: the study area definition and identification and quantification; analysis of the municipality land use plans; analysis of the official web sites of the 133 municipalities; digitization of the MCGs areas; ground control through direct survey of the digitized MCGs areas and creation of a GIS database of the MCGs areas. The purpose of the study is to requalify the marginal and urban fringe areas, for improving environmental and life quality in urban and suburban degraded areas. In this view, MCGs represent an urban and social service to improve through decisions supported by careful planning of interventions.

Source: <https://dx.doi.org/10.4081/jae.2016.509>, | Photo credit: -



# Bioretention area



Bioretention is a technique to reduce and filter peak stormwater runoff through a system of layered organic and inorganic materials. Bioretention cells consist in shallow depressions where the water runoff is collected: and rely on soils, vegetation and filtration removing pollution and reducing runoff. Properly designed cells remove suspended solids, metals, and nutrients, and can retain an inch or more of rainfall. Stored water can then exfiltrate slowly, over a period of days, into the underlying soil.

## Challenges

## Objectives

## Performances



Energy sustainability



Energy demand



Carbon impact



Energy produced from RES



Energy from RES on site



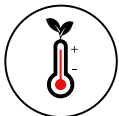
Low carbon material use



Greening



Energy efficiency



Temperature regulation



Local microclimate



UHI



Temperature surface/air



Outdoor thermal comfort



Shadow effect



Water management



Run off mitigation



Water scarcity



Water quality



Water retention



Water storage and reuse



Water treatment



Health and wellbeing



Comfort and life quality



Urban space quality



Green space



Space for socialization



Air quality



Walkability

Other benefits



Biodiversity



Noise pollution



Flexibility



Storage



Artistic expression



Easy to repair

## Regulations & Standards

## Strategies

## Scale of application



Space usage

Monofunctional  
Multifunctional



S.D.G.

P 6.0 S 13.0  
11.0 15.0



Disadvantages

Requires landscaping and management  
Not suitable for areas with steep slope





# Temperature regulation

---



## *Temperature surface/air*

Several studies show that bioretention areas can reduce the temperature of thermally charged stormwater runoff received from an asphalt surface.

*Case study:* bioretention site located at the Community Center parking lot in Blacksburg (Virginia). Its facility was designed as a retrofit to treat the entire 0.73 ha asphalt parking lot. It is 27 m long, 3.7 m wide, and 1.3 m deep and it is filled with CU-Structural Soil composed of approximately 80% crushed stone and 20% clay loam soil held together with hydrogel. The results show that bioretention facility reduced thermal energy in average by 8.8°C. The average influent temperature for the 10 runs was 34.0°C, while the average effluent temperature was 25.2°C [5].

## References

- [1] R. D. Stewart, J. G. Lee, W. D. Shuster, and R. A. Darner, *Modelling hydrological response to a fully-monitored urban bioretention cell*, Hydrological process Volume31, Issue26 (30 December 2017)Pages 4626-4638, <https://doi.org/10.1002/hyp.11386>
- [2] M. H. Frosi, M. Kargar, P. Jutras, S. O. Prasher and O. G. Clark, *Street Tree Pits as Bioretention Units: Effects of Soil Organic Matter and Area Permeability on the Volume and Quality of Urban Runoff*, Water, Air, & Soil Pollution volume 230, Article number: 152 (2019), <https://doi.org/10.1007/s11270-019-4197-7>
- [3] S. Kim and K. An, *Exploring Psychological and Aesthetic Approaches of Bio-Retention Facilities in the Urban Open Space*, Sustainability 2017, 9 (11), 2067, <https://doi.org/10.3390/su9112067>
- [4] R. A. Tirpak, J. M. Hathaway, J. A. Franklin and E. Kuehler, *Suspended pavement systems as opportunities for subsurface bioretention*, Ecological Engineering 134 (September 2019) Pages 39–46, <https://doi.org/10.1016/j.ecoleng.2019.05.006>
- [5] D. L. Long and R. L. Dymond, *Thermal Pollution Mitigation in Cold Water Stream Watersheds Using Bioretention*, JAWRA 50 – 4 (August 2014) Pages 977-987, <https://doi.org/10.1111/jawr.12152>

# Water management



## Water retention

The capability of bioretention areas to retain stormwater depends on design: for example, smooth inlet systems may lead to more flow through the structure and thus potentially better retention. In addition, the presence and configuration of underdrain systems can also limit the retention characteristics of retention cells.

*Case study:* a bioretention cell located in Cleveland (Ohio, dfa zone). It is composed of a sandy substrate amended with compost and an aggregate base layer designed for stormwater storage, collecting runoff from transportation surfaces, rooftops, and sidewalks. Collected data was used to calibrate a hydrological model of the cell. The results show that the mean soil water content increased by ~8% with respect to the case without the retention cell. [1].



## Water treatment

Bioretention areas have proved great efficiency (70%) in absorbing toxic water contaminants such as naphthalene and suspended solids in runoff waters. Recent projects have demonstrated a potential use in denitrification of waters using wood chips as filter media while other studies indicate a reduced mass flow of contaminants in cells with increased soil organic matter (SOM).

*Case study:* concentration and mass flux of contaminants (Na, Cr, Ni, Cu, Zn, Cd, Pb) were measured in soil samples from street tree pits used as bioretention areas in Montreal, Canada. Tree pits with higher SOM reduced the mass flux of contaminants more than tree pits with lower SOM. The estimated water flux in the open part of the tree pit changed from 6.15 to 1.64 mm week<sup>-1</sup> from the less permeable units to the more permeable ones [2].

# Health and wellbeing



## Green space

Bioretention facilities incorporate patches of urban green spaces, proved to positively affect mental health and wellbeing, while reducing the content of toxic pollutants that reach groundwaters.

*Case study:* a recent survey investigating their role on landscape aesthetics proved low perceived impact, as only 1 in 3 interviewees recognized the difference with conventional gardens. The same study showed a high degree of favour towards its function and concept [3].



## Walkability

Different project proposed to use urban tree pits on sidewalks as bioretention areas. In this view, a recent study has shown that bioretention areas can be effectively used as suspended pavement systems for sidewalks, roadways and parking areas.

*Case study:* bioretention areas have been installed in suspended pavement systems in Knoxville, Tennessee. It was monitored for 27 months showing a runoff reduction between 88% and 99% [4].



# Bioretention area: best practice

## Project name

A public square in Ostia Lido

## Climate zone

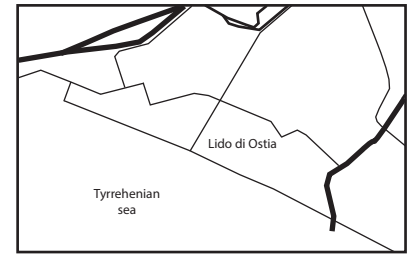
Csa - Hot-summer Mediterranean climate

## Construction year

2019

## Location

Rome, Lazio, Italy

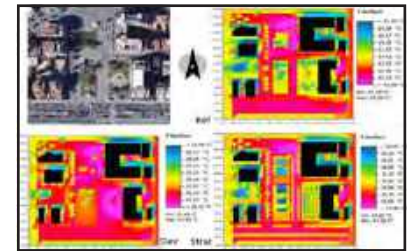


## Runoff

The results obtained through the SCS Curve number method show a significant reduction of the runoff in the Strat scenario, confirming the effectiveness of the adopted. Specifically, the runoff values are: 67.11 mm for Ref; 90.84 mm for Dev; and 42.21 mm for Strat.

## Temperature

In Ref, temperatures on the sidewalks are similar to Dev, but much lower Tsurf are visible in the squares (32-34°C) as well as slightly lower Tmr, equal to 66°C. Strat displays even lower Tsurf, 28-35°C in the green squares, while the water ponds reach even lower temperatures. Tmr is lower especially in the squares (64°C, and as low as 42°C close to the trees), where trees are present.



## How it works

Bioretention "cells" are landscaped depressions or shallow basins filled with sandy soil, topped with a thick layer of mulch, and planted with dense vegetation. They are used to slow and treat on-site stormwater runoff. Stormwater runoff slowly percolates through the system where it is treated by a number of physical, chemical and biological processes; some of the water is also taken up by the plants and the other part is allowed to infiltrate native soils. The main objectives of this solution are to provide water quality treatment removing suspended solids, metals, and nutrients, to increase groundwater recharge and to reduce peak discharge rates.



## Description

Sustainable Urban Drainage Systems (SUDS) are flood mitigation strategies specifically designed positively affect urban microclimate and outdoor thermal comfort. The area is 140x140 m wide, mainly composed of urban paving and asphalt roads and sidewalks. In addition, three green areas contain non irrigated soil and plants such as palm trees. Different future scenarios were modelled and tested in comparison with the reference case study on ENVI-met. The scenarios tested runoff capacity. The scenarios were three: "Ref" scenario as reference; "Strat" scenario: green, irrigated areas with trees and permeable paving for the parking lots and water ponds in the green areas. Finally, a "Dev" scenario characterised by impermeable paving.



# Phytodepuration

Phytodepuration is a natural treatment technique inspired by natural paludal ecosystems, that reproduces artificially the natural purification process in a controlled environment. Practically, it is basen on artificial little deep basins, often filled with inert material and fed with aquatic plants (macrophytes). The macrophytes can be floating, flooded or emerging. The systems can have superficial or sub-superficial streams, in addition, the sub-superficial stream can be horizontally or vertically oriented. Superficial streams can support all the types of macrophytes, on the other hand the sub superficial can just support the emerging macrophytes.



## Challenges

## Objectives

## Performances



Energy sustainability



Energy demand



Carbon impact



Energy produced from RES



Energy from RES on site



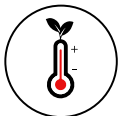
Low carbon material use



Greening



Energy efficiency



Temperature regulation



Local microclimate



UHI



Temperature surface/air



Outdoor thermal comfort



Shadow effect



Water management



Run off mitigation



Water scarcity



Water quality



Water retention



Water storage and reuse



Water treatment



Health and wellbeing



Comfort and life quality



Urban space quality



Green space



Space for socialization



Air quality



Walkability

Other benefits



Biodiversity



Security/Safety



Food production



Flexibility



Easy to repair

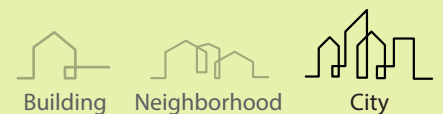


Artistic expression

## Regulations & Standards

## Strategies

## Scale of application



## Space usage

## S.D.G.

## Disadvantages

Monofunctional  
Multifunctional

P 6.0 S 13.0  
11.0 14.0

Accumulation of pollutant in edible plants  
Maintenance costs  
Some place/just for some plants

# Temperature regulation

# Water management



## Temperature surface/air

Several studies show that phytodepuration systems can help to reduce the temperature based on their shape, the plants chosen and the location.

*Case study:* the "Infinite Green" located in the city centre of Wrocław (Poland). The structure with the dimensions of 1000 × 360 × 500 cm and the distance between shelves of about 51 cm, consists of seven levels of horizontal plywood frames that are joined by steel masts. It has 120 m<sup>2</sup> of growing area, including 120 plant species and varieties of 63 genera were used, with the most numerous species and varieties of the genera Sedum (13), Geranium (9), Campanula (5) and Dianthus and Festuca. The results show that during the colder days, the temperatures significantly decrease up to 2–3 °C less [1].



## Water treatment

Phytodepuration is one the most efficient solution to treat the water and guarantee its quality.

*Case study:* vast abandoned areas of former industrial plants located in Turin (Italy, Cfa zone). According to Italian laws, a part of the ex- industrial areas was allocated to green infrastructures. However, the restoration of the green areas had to deal with the problem of soil contamination. The surface of the experimental plot was about 0.1 ha, and the selected species for the experiment are from Populus, Salix. and Robinia genera. The results show that the Zn root uptake was constant over the two years for Poplar and Salix clones, between 6% and 17% of the total uptake of the plant. Robinia genotypes, instead, stored higher amounts of metals in roots using biennial coppicing (up to the 23% of the total), mostly due to the higher root biomass developed under this management. In addition, the decreasing of Zn was significant for all clones at the end of the experiment, and, on average, Poplar clones reduced Zn by 28%, Salix by 36%, and Robinia 26%.

Another interesting case is [2], [3].

## References

- [1] K. Bandurski, H. Bandurska, E. Kazimierzak-Grygiel and H. Koczyk, *The Green Structure for Outdoor Places in Dry, Hot Regions and Seasons - Providing Human Thermal Comfort in Sustainable Cities*, Energies 13 (2020) 2755, [doi:10.3390/en13112755](https://doi.org/10.3390/en13112755)
- [2] E. Padoan, I. Passarella, M. Prati, S. Bergante, G. Facciotto and F. Ajmone-Marsan, *The Suitability of Short Rotation Coppice Crops for Phytoremediation of Urban Soils*, Appl. Sci. 2020, 10(1), 307, <https://doi.org/10.3390/app10010307>
- [3] I. Adesina, A. Bhowmik, H. Sharma and A. Shahbazi, *A Review on the Current State of Knowledge of Growing Conditions, Agronomic Soil Health Practices and Utilities of Hemp in the United States*, Agriculture 2020, 10(4), 129, <https://doi.org/10.3390/agriculture10040129>

Synonymous and other strategies: <https://doi.org/10.3390/ijerph18105215>





# Phytodepuration: best practice

## Project name

Effectiveness of in situ application of an Integrated Phytoremediation System (IPS) by adding a selected blend of rhizosphere microbes to heavily multi-contaminated soils

## Construction year

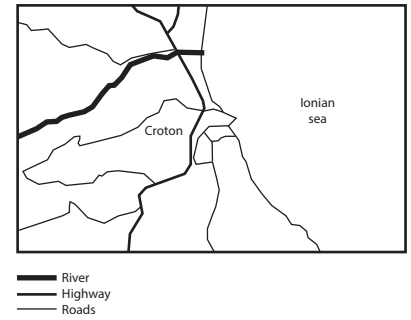
2017

## Climate zone

Csa - Hot - summer Mediterranean climate

## Location

Crotone, Calabria, Italy



## Arsenic

The percentage reduction of As in average is 61%. The Eucalyptus rhizosphere microbes system provided the best results with a total percentage reduction of 63%.

## Cadmium

The percentage of Cd content in soil increase of 25% and 38% in plots cultivated with *A. saligna* and *E. camaldulensis*, respectively. In particular, the Eucalyptus rhizosphere microbes system provided the best results with a total percentage reduction of 56%.



## Lead

The percentage reduction of Pb has an average value of 52%. *Acacia saligna* highlighted a strong ability to uptake Pb from rhizosphere soil and increases the efficiency of 14%.

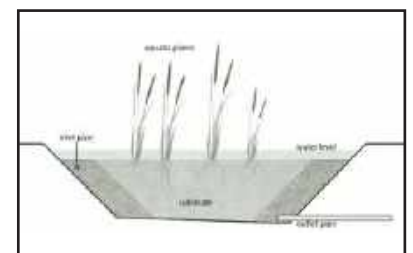
## Zinc

The removal of Zn from soil showed the highest values of percentage reduction in both *Acacia* and *Eucalyptus* with an average value of 83%.



## How it works

Phytodepuration system is made of artificial little deep basins, often filled with inert material and fed with aquatic plants (macrophytes). The soil consists in a single complex system of biological competition towards the bacteria, that has the active role in mechanical and chemical filtration. The soil's microfauna degrades the organic load of the wastewater turning it into nutrients for the plant species in the system. Finally, the vegetation reproduces the natural purification processes bringing oxygen in deep through the roots and absorbing nutrients from the soil.



## Description

The former Zn smelter "Pertusola Sud" is located in Crotone (Calabria, Italy). The full site is about 50 ha, divided in different working sectors, but the investigation focused on 5 ha called "Area Sottoprodotti" (By-products Area). The soil was heavily contaminated by PTEs (mainly, As, Cd, Pb and Zn), especially top soil (0–1 m) with the presence of clay layers. In the site, five ecologically homogeneous areas were identified. Area A is an open scrub vegetation of shallow damp sandy soil and area B is a wet zone. Areas C and D host annual and perennial communities. Bare soil is the distinctive trait of area E. In addition, areas A and B are characterized by *Acacia saligna* (Labill.) H.KL. Wendl (subzone A e B) and *Eucalyptus camaldulensis* Dehnh (subzone C e D). They were chosen for their phytoremediation capacity and for their capacity to quickly produce high amounts of biomass and absorb and accumulate contaminants.

Source: <https://doi.org/10.1016/j.ecoleng.2016.11.051>, | Photo credit: -

#### 4.5 Types of digital solutions

The digital solutions reported in this catalogue are a synthesis of the main Industry 4.0 technologies that could support all the life cycles stages in construction process of the Built Environment. In particular, all the digital solutions have been assessed on the ability to respond to the climate-related challenges. In addition, it has been evaluated the other benefits, the possible uses in the life cycle construction process and the possible integration with other digital technologies to satisfy one or more climate objectives.

In this section it has been added a challenge related to the transition to circular system, to analyse the role of digital solutions in a more holistic and coherent way to climate change, in order to respond to the objectives of circular infrastructures and buildings and circular materials and products.

The assessment of structures built and demolished or the quantification of abandoned structures in built environment are fundamentals to support the transition of infrastructures and buildings. The analysis of potential re-use and recycling of materials, the inventory of exterior buildings and infrastructures materials and the mapping of properties for demolition are key performances able to satisfy the transition to circular system of materials and products of Built Environment.

Solutions	Climate related challenge addressed				
	ES	TR	SWM	HW	CE
Additive Manufacturing/Robot manufacturing					
Artificial Intelligence (AI)	X	X	X	X	X
Big Data and Analytics (BDA)					
Blockchain Technology (BCT)	X				X
Building Information Modelling (BIM)	X	X	X	X	X
Digital Platform					
Digital Twin	X	X	X	X	X
Geographic Information Systems (GIS)	X	X	X	X	X
Material passport					
Internet of Things (IoT)	X	X	X	X	X
Augmented Reality (AR) and Virtual Reality (VR)					

#### 5. Towards an integrated framework for Climate Positive Circular Communities

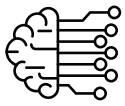
The present catalogue has been collected, systematise and categorized some possible measures that can respond to different challenges such as energy sustainability, temperature regulation, water management, health and wellbeing. These measures could respond at different scale (building, neighbourhood or city) both for mitigation and adaptation strategies for climate change in Built Environment. In addition, it has been

underlined for each measure the benefits not only from the environmental point of view but also from social point of view. Some measures could insert in the range of Nature Based Solution and Blue Infrastructures and they are able to absorb the CO<sub>2</sub> emissions already present in the atmosphere while reducing the production of new emissions (zero net carbon emissions). This approach is in line with the principle of climate positive, that consists in implementing additional measures in order to create an environmental benefit. At the same time, digital solutions that can support the transition to circular system complete the catalogue to increase the efficiency and effectiveness of measures to reduce the greenhouse gas emissions and increase the benefits (less carbon emission, less water consumption and less waste consumption). The benefits of a holistic and simultaneous strategy could lead to a reduction in the cost of emissions that affect urban climates and can also avoid maladjustment measures by providing support in the realization of other sustainable development goals.

**DIGITAL  
SOLUTIONS**



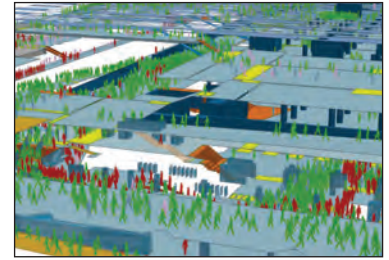




# Artificial Intelligence (AI)

Many definitions of AI exist. At a basic level, AI refers to "the ability of a computer or machine to mimic the capabilities of the human mind" (IBM, 2020). The use of AI in city management relates to the collection, interpretation and analysis of data in support of policy-related decision-making and planning. AI can exert far-reaching impacts in numerous application areas, and several of these are critical for city management and urban development, including local government, health, safety, mobility and energy.

Progress in combining AI with other digital technologies (Big Data, Internet of Things (IoT), Cloud and telecommunications infrastructure) making possible full interconnectivity is driving the development of smart-cities, aiming to make the most of such technologies to increase the quality of life and wellbeing of citizens.



## Challenges



Energy sustainability



Temperature regulation



Water management



Health and wellbeing



Transition to circular system

## Objectives



Energy efficiency



Carbon impact



Energy produced from RES



Local microclimate



UHI



Runoff mitigation



Water scarcity



Water quality



Comfort and life quality



Urban space quality



Circular Infrastructures and buildings



Circular Materials and products

## Other benefits



time reduction



increase of efficiency



increase of effectiveness



better governance



better data management

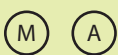


real time monitoring

## AI uses in construction life cycle of Challenges



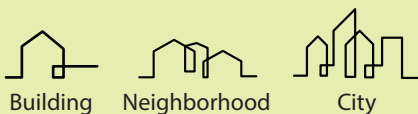
## Strategies



## S.D.G.

6.4 11.3 13.1  
11.b 13.2

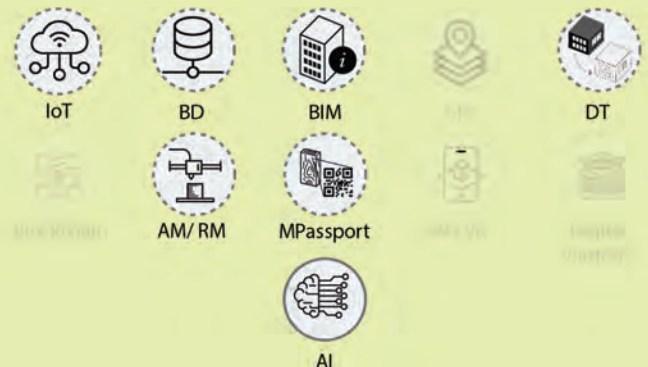
## Scale of application



## Disadvantages

+ long implementation process  
+ high level of complexity  
+ engagement of different disciplines and competences

## Potential linkages with other DTs



## Energy sustainability



AI has a great potential to improve the level of energy sustainability in Built Environment. Focusing on the energy performance and energy consumption, [1] have investigated the application of field measurement, computer modelling (AI) and survey to improve energy performance as well as thermal comfort using new system utilizing “big data” and AI in extreme hot regions, finding that energy consumed in the west facing apartment was higher than 20%. In addition, [2] have underlined the possible application of AI techniques (such as machine learning) to energy forecasting, air quality, occupancy strategy for built environment.



## Temperature regulation

AI techniques have showed benefits to detect UHI phenomenon that is interesting the built environment in the last years. [3] have investigated the impacts of surface UHI and land surface temperature with the application of landsat images and machine learning algorithms to identify urban growth, land surface temperature and UHI distribution patterns in several city directions. Through this study, researchers have demonstrated the influence of built-up areas to land surface temperature and surface urban heat island and in the future this findings could support the increase of built environment thermal comfort.

## Water Management



Built environment around the world is threatened by the water scarcity induced by the effects of climate change. In this scenario, water leakage in existing water distribution channel have exacerbate water scarcity problem in urban areas. To check and control water leakage in cities lies in operating Real-Time sensors Networks with Machine Learning [4]. While Real-Time Sensor Network monitors workflow in real time, machine learning model will be able to predict and anomaly, and can accurately detect the same in the water distribution network.



## Health and Wellbeing

Various studies have conducted to assess the indoor environmental quality, in particular with the attention to building and human interaction using AI technologies. Breeze Technologies start-up wants [5] to fight the air pollution urban problem through the use of data-drive, AI-supported environmental intelligence that creates actionable insights based on sensor data. One of the most recent application of Breeze technologies is in Vilnius. Equipped with the rich air quality data provided by sensors, planning offices are already making progress toward improving happiness and health outcomes in the city.

## Transition to circular system



AI characteristics offer a number of opportunities to favour the transition of built environment from linear to circular system. [6] have reported the application of AI into 3 main stage of life construction cycle. Firstly, the AI can support the design optimisation, through data driven approaches (such as neural network) to provide advanced solution for for the generation of multiple design alternatives considering some parameters (e.g. carbon footprint). Secondly, AI techniques provide capabilities to predict defects in systems and resource needs in building. Finally, AI techniques are also useful for end-use phase activities, for example to predict the amount of recyclable, reusable and waste materials generated from deconstruction and demolition projects.

## References

- [1] Alwetaishi M, Shamseldin A. *The use of artificial intelligence (AI) and Big-Data to improve energy consumption in existing buildings*. IOP Conf Ser: Mater Sci Eng. 2021 May 1;1148(1):012001. <https://doi.org/10.1088/1757-899X/1148/1/012001>
- [2] Tien PW, Wei S, Darkwa J, Wood C, Calautit JK. *Machine Learning and Deep Learning Methods for Enhancing Building Energy Efficiency and Indoor Environmental Quality – A Review*. Energy and AI. 2022 Nov;10:100198. <https://doi.org/10.1016/j.egyai.2022.100198>
- [3] Saha M, Kafy AA, Bakshi A, Faisal AA, Almulhim AI, Rahaman ZA, et al. *Modelling microscale impacts assessment of urban expansion on seasonal surface urban heat island intensity using neural network algorithms*. Energy and Buildings. 2022 Nov;275:112452. <https://doi.org/10.1016/j.enbuild.2022.112452>
- [4] World Economic Forum. Water [Internet]. *Machine Learning can help protect urban water. Here's how*; 2022 [updated 2022; cited 2022 Nov 21]. Available from: <https://www.weforum.org/agenda/2022/04/how-to-prevent-urban-water-stress-through-machine-learning/>
- [5] Urban AI [Internet]. *Tackling Air pollution with Urban AI*; 2021 [updated 2021; cited 2022 Nov 21]. Available from: <https://medium.com/urban-ai/tackling-air-pollution-with-urban-ai-294786481781>
- [6] Çetin S, De Wolf C, Bocken N. *Circular Digital Built Environment: An Emerging Framework*. Sustainability. 2021 Jun 3;13(11):6348. <https://doi.org/10.3390/su13116348>



## AI: best practice

### Project name

FaSA (Façade Service Applicatie)

### Year

2018, ongoing

### Location

Nieuwegein, The Netherlands



### Transition to circular economy

Sensors, drones and artificial intelligence are used for this. These measurements are automatically brought together, analyzed and result in strategic management of facade maintenance.

This application not only maps the current state of buildings, but also predicts future maintenance using smart algorithms. In addition, according to the facade industry, this technology makes it possible to determine the value of real estate more accurately over a longer period of time. This is important for the reuse of products and raw materials in a circular economy.



### Other uses and digital applications

The corporations involved in the development of FaSA see the application as a way to increase the affordability of housing because of lower maintenance costs.

### Description

How nice it would be if the maintenance of a building has already been done before a problem arises in a building. Now this usually happens periodically and often only when there are already problems. FaSA enables maintenance right on time.

Inspectors conduct periodic inspections. This is time-consuming, especially for large real estate projects, and is a subjective assessment of the condition of the building. There is a need for objective information to achieve better strategic management and maintenance of buildings. This is possible through digitization of maintenance inspections. With smart algorithms it is then possible to predict future maintenance. The maintenance is then done exactly on time. And that has advantages:

- Lower maintenance costs
- Higher residual value
- Fewer health complaints

Source: <https://facadeserviceapplicatie.nl/>



# Blockchain Technology (BCT)

The concept is based on a distributed peer-to-peer system that is cryptographically secured, enabling transparent value transactions without needing central authorities and intermediaries such as banks and government agencies.

IBM defines five disruptive elements of BCT: transparency, immutability, security, consensus and smart contracts.

Hunhevicz and Hall (2020), identified twenty-four potential use cases of BCT in the BE, which include: using smart contracts to automate transactions between external actors, tracking supply chain logistics, timestamping changes in BIM models, recording the ownership of assets, maintaining material passports, and automating building maintenance based on IoT interactions.



## Challenges



Energy sustainability



Temperature regulation



Water management



Health and wellbeing



Transition to circular system

## Objectives



Energy efficiency



Carbon impact



Energy produced from RES



Local microclimate



UHI



Runoff mitigation



Water scarcity



Water quality



Comfort and life quality



Urban space quality



Circular Infrastructures and buildings



Circular Materials and products

## Other benefits



time reduction



increase of efficiency



increase of effectiveness



better governance

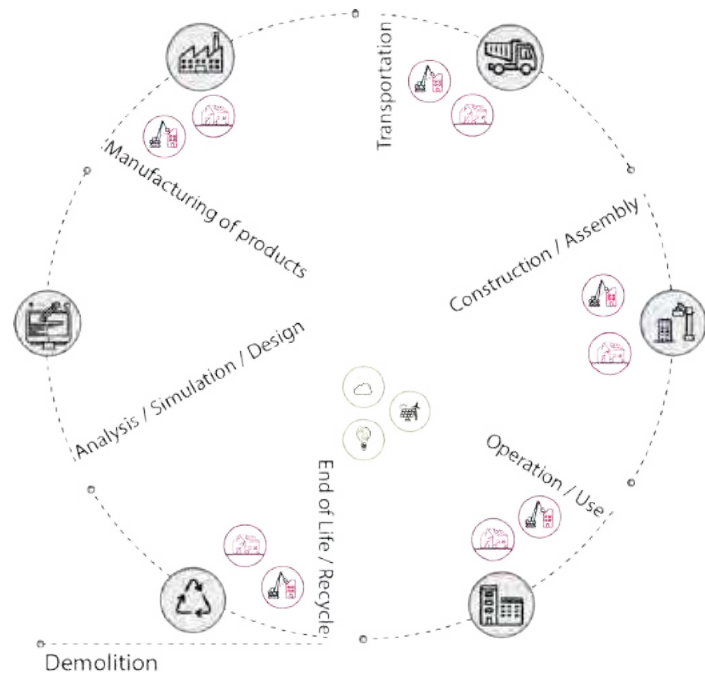


better data management

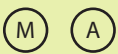


real time monitoring

## BCT uses in construction life cycle of Challenges



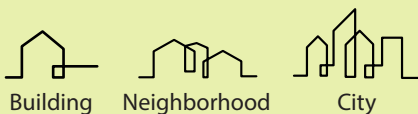
## Strategies



## S.D.G.

6.4 11.3 13.1  
11.b 13.2

## Scale of application



## Disadvantages

+ long implementation process  
+ high level of complexity  
+ engagement of different disciplines and competences

## Potential linkages with other DTs



## Energy sustainability

---



BCT can support safe peer-to-peer trading networks. This attribute enable BCT to adapt to local renewable energy exchange, in which intermittency is a big obstacle. As reported by [1], BCT could avoid this issue and support local communities to increase safety, transparency and cost-efficient energy trading. For example, Pando enhance users to buy and receive local renewable energy within their neighborhoods through a mobile app.

## Transition to circular system

---



As reported by [2], BCT will increase the development of circular economy paradigm in built environment in the next years. In particular in the construction process characterized by circular economy approach, BCT can enable the material passport systems [3], because it offers transparency and reliability of data flows accross the supply chain network, from extraction until end-of-use phase, and further in subsequent use.

## References

- [1] 1. Mengelkamp E, Notheisen B, Beer C, Dauer D, Weinhardt C. *A blockchain-based smart grid: towards sustainable local energy markets*. Comput Sci Res Dev. 2018 Feb;33(1-2):207-14. <https://doi.org/10.1007/s00450-017-0360-9>
- [2] ARUP. *Blockchain and the Built Environment*. London: ARUP; 2019.
- [3] Çetin S, De Wolf C, Bocken N. *Circular Digital Built Environment: An Emerging Framework*. Sustainability. 2021 Jun 3;13(11):6348. <https://doi.org/10.3390/su13116348>





## **BCT: best practice**

### **Project name**

Circularise (Start-up) - City of Amsterdam

### **Year**

2020

### **Location**

Amsterdam, Netherlands



### **Transition to circular system**

As part of the Amsterdam Circular Strategy, the City has set clear targets to halve the use of new raw materials by 2030 and to become a fully circular city by 2050. These targets bring challenges to the table when it comes to managing MKI-data (environmental costs calculation, focusing on CO<sub>2</sub> emissions) from their construction procurement. The Start-up in Residency program outlines how Circularise partnered with the City of Amsterdam to increase traceability and transparency throughout their construction procurement process.

During this project Circularise joins forces with a concrete product company and a company that recycles workwear into polymer infrastructure elements. Circularise's software solution ensures that both of these materials are traced end-to-end throughout the supply chain and that information can be shared without risking sensitive data. This supports the goal of the City of Amsterdam to create a standard for gathering procurement environmental impact insights from the upstream supply chain, without compromising confidential data of anyone involved.

### **Other uses and digital applications**

Others applications of the BCT made by Circularise start up have focused on other manufacturing sector, such as automotive, for example with the project for Porsche company in order to enable the access to reliable information, to understand the environmental impact of products making the information useful for the consumer.



### **Description**

End-to-end Supply Chain Traceability holds the key to overcoming major challenges that society faces in the areas of Circular Economy, Environmental Pollution, Carbon Emissions. But the race to Sustainability is held back by concerns around trust, privacy and confidentiality, as the available material data is often not accessible, proprietary or incomplete.

Circularise enables supply chain actors to share sensitive data without risking privacy and confidentiality.

To improve Resource Use, Verify Provenance, Conduct Carbon Footprint and Impact Assessments to unlock the potential of Circular Economy business models and to drive worldwide adoption.

Source: <https://www.circularise.com/company> and <https://www.circularise.com/video/case-study-city-of-amsterdam>



# Building Information Modelling (BIM)

BIM has had a big diffusion in the last 10 years of the Architecture, Engineering and Construction sectors (AECs) supporting various purposes such as design, design visualisation, design optimisation, cost estimation, construction planning, maintenance and facility management and containing relevant information about buildings geometry, material properties and quantities of elements (Çetin et al., 2021).

BIM represents a core technology for transferring the idea of Industry 4.0 in the AECs (Begic & Galic, 2021). It has an important tool for the bidirectional coordination among physical and virtual domains (Maskuriy et al., 2019). Various subsets of BIM can be referred to as dimensions, where 3D is the object model, 4D is time, 5D is cost, 6D is operation, 7D is sustainability, and 8D is safety.



## Challenges



Energy sustainability



Temperature regulation



Water management



Health and wellbeing



Transition to circular system

## Objectives



Energy efficiency



Carbon impact



Energy produced from RES



Local microclimate



UHI



Runoff mitigation



Water scarcity



Water quality



Comfort and life quality



Urban space quality



Circular Infrastructures and buildings



Circular Materials and products

## Other benefits



time reduction



increase of efficiency



increase of effectiveness



better governance



better data management



real time monitoring

## BIM uses in construction life cycle of Challenges



## Strategies



## S.D.G.

6.4 11.3 13.1  
11.b 13.2

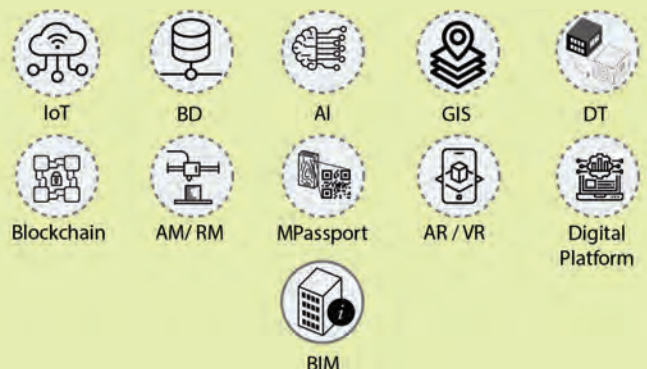
## Scale of application



## Disadvantages

+ long implementation process  
+ high level of complexity  
+ engagement of different disciplines and competences

## Potential linkages with other DTs



## Energy sustainability



BIM can be a valid support tool to green building approach in line with the energy sustainability challenge. In particular all of the three stages in construction process could be covered by the benefits of its use. As argue by [1] during the design phase, BIM with the integration of Life Cycle Assessment methods could promote the selection of sustainable materials and sustainability performances to reduce carbon emissions. During the construction phase [2], BIM can support the simulation not only of the impacts on surrounding environment but also the prediction of construction processes and risks.

## Water Management



Water scarcity and water efficiency are objectives that BIM analysis could support. In particular [4] have investigated the potential of BIM to assessing rainwater harvesting potential in urban areas where BIM could feed the model development in Infraworks through information about some building parameters such as household size, roofing materials and roofing size. Water efficiency, is the main goal of the study of [5], in order to compare different BIM tools to assess the applicability Revit Green Project Template (RGPT), Autodesk Green Building Studio (GBS) and automated GBI assessment tool (AGBIA) with the use of Dynamo.

## Transition to circular system



[8] argue that BIM is fundamental to the technological development of circular economy strategies in construction sector and in built environment to reduce resource consumption and waste creation. [9] used material information extracted from BIM to accurate estimation of recoverability and recyclability of a construction and demolition waste. [8] sustain that BIM contribute to a reconstructed 3D model to establish a deconstruction waste management system. More efficient construction and demolition waste could be achieved through BIM combined with a system dynamic simulation to minimise waste production generation from change orders [8].

## Temperature regulation



BIM could provide a model and information to support urban microclimate analysis to understand the outdoor comfort. For example, as reported by [3] through plug-ins could be possible to access to BIM information, extract subsets of object information, update BIM parameters, and execute performance simulations by Grasshopper platform. Three plug-ins enabled the use of validated simulation engines of Radiance, EnergyPlus, and OpenFOAM for microclimate variables of wind analysis, solar accessibility, energy use.

## Health and Wellbeing



In the last years BIM has gained a lot of attention also to understand indoor and outdoor human comfort. Studies [6,7] were developed on the application of BIM to analyze some health parameters in indoor environment to calculate some indicators such as thermal comfort, volatile organic compound (VOC), formaldehyde concentration, thermal zoning and controls, daylight factor, sound insulation, indoor ambient noise level, room acoustics, security, safe access, outside space, views of nature, sedentary lifestyles and illuminance levels.

## References

- [1] Liu Z, Li P, Wang F, Osmani M, Demian P. *Building Information Modeling (BIM) Driven Carbon Emission Reduction Research: A 14-Year Bibliometric Analysis*. IJERPH. 2022 Oct 6;19(19):12820. <https://doi.org/10.3390/ijerph191912820>
- [2] Cao Y, Kamaruzzaman S, Aziz N. *Green Building Construction: A Systematic Review of BIM Utilization*. Buildings. 2022 Aug 10;12(8):1205. <https://doi.org/10.3390/buildings12081205>
- [3] A. Globa, J. van Ameijde, A. Fingrut, N. Kim. *Forecasting performance of Smart Growth development with parametric BIM-based microclimate simulations*. T.T.S. Lo (eds.), PROJECTIONS - Proceedings of the 26th CAADRIA Conference - Volume 1, The Chinese University of Hong Kong and Online, Hong Kong, 29 March - 1 April 2021, pp. 411-420. <https://doi.org/10.52842/conf.caadria.2021.1.411>
- [4] 1. Maqsoom A, Aslam B, Ismail S, Thaheem MJ, Ullah F, Zahoor H, et al. *Assessing Rainwater Harvesting Potential in Urban Areas: A Building Information Modelling (BIM) Approach*. Sustainability. 2021 Nov 15;13(22):12583. <https://doi.org/10.3390/su132212583>
- [5] Khoshdelnezamiha G, Liew SC, Shin Bong VN, Ong DEL. *EVALUATION OF BIM APPLICATION FOR WATER EFFICIENCY ASSESSMENT*. Journal of Green Building. 2020 Sep 1;15(4):91–115. <https://doi.org/10.3992/jgb.15.4.91>
- [6] D'Amico A, Bergonzoni G, Pini A, Currà E. *BIM for Healthy Buildings: An Integrated Approach of Architectural Design based on IAQ Prediction*. Sustainability. 2020 Dec 12;12(24):10417. <https://doi.org/10.3390/su122410417>
- [7] Rice L. *Healthy BIM: the feasibility of integrating architecture health indicators using a building information model (BIM) computer system*. ARCH. 2020 Dec 18;15(1):252–65. <https://doi.org/10.1108/arch-07-2020-0133>
- [8] Yu Y, Yazan DM, Junjan V, Iacob ME. *Circular economy in the construction industry: A review of decision support tools based on Information & Communication Technologies*. Journal of Cleaner Production. 2022 May;349:131335. <https://doi.org/10.1016/j.jclepro.2022.131335>
- [9] Akanbi LA, Oyedele LO, Akinade OO, Ajayi AO, Davila Delgado M, Bilal M, et al. *Salvaging building materials in a circular economy: A BIM-based whole-life performance estimator*. Resources, Conservation and Recycling. 2018 Feb;129:175–86. <https://doi.org/10.1016/j.resconrec.2017.10.026>





# BIM: best practice

## Project name

Data-driven Landscape design with LIM®  
From Building Information Modelling (BIM)  
to Landscape Information Modelling (LIM®)

## Year

2019

## Location

Milan, Italy

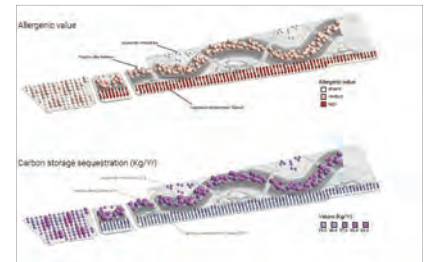


## Water management

The combination of BIM with other open sources data and the integration with GIS has developed the possibility to assess different design scenarios in Built and Natural Environment in order to understand the water performance of open air spaces. In particular the LIM® project based on BIM technology is able to calculate the water demand (Daily total amount of water requested for trees growth [ l / d ]), the total annual benefits (sum of values relating to the ecosystem services generated annually [€ / Yr ]), and the avoided runoff (amount of carbon sequestration interpreted as CO<sub>2</sub>-Eq. [ Kg / Yr ]). These metrics could contribute to calculate some parameters related to the urban project development from building scale to district scale.

## Health and Wellbeing

LIM® system has some potentials in terms of health and wellbeing for outdoor comfort. In particular the system can calculate some parameters related to the quality of air and the green space. For example, air quality can be measured to quantify carbon dioxide sequestration (amount of carbon sequestration interpreted as CO<sub>2</sub>-Eq. [ Kg / Yr ]), oxygen production (amount of Oxygen (O<sub>2</sub>) annually produced by the photosynthetic process [ Kg / Yr ]). For green space, the system allow to calculate some parameters related to the level of permeability, such as biotope area factor, normalized difference moisture index, green space factor and normalized difference vegetation index.



## Other uses and digital applications

By combining the application of BIM, GIS and visualization tools on a database specially developed for this purpose collecting LAND knowledge on the field and validated calculation procedures, it allows to quantify environmental parameters, simulate green growth, and impacts by providing spatial inputs and visualizations, and build a sustainability pre-assessment to support design decisions, approval processes and future maintenance. In addition with other metrics, LIM® is able to get some information during the design process about tree, such as total canopy cover (total area of the project covered by trees canopies [ squared meters ]), trees characteristics (trees' species types, agronomic characteristics, species number ratios in project), time (visualition of plants and parameters growth. time to ultimate height and growing speed rate. Maintenance frequency) and allergenic values (indicates whether the trees produce potentially allergenic pollen [ absent / low / medium / high]).

## Description

The LIM® Landscape Information Modelling service through the use of nature-based solution and a data driven approach, offers, in addition to the common data that can be extracted from the BIM modelling software, information that quantifies the environmental and partly socio-economic performance of the landscape project. With the inclusion in the BIM methodology of the eighth dimension, or 8D environmental dimesion, LAND, through the LIM®, wants to revolutionize the way it designs urban landscapes by measuring the impact on air quality, the management of water resources and soil conditions to improve the well-being of the people living in those places and monitor their sustainability. The work of the multidisciplinary team of LAND, which is translated and coded in a digitalized language applicable to the LIM® methodology, provides both a design proposal that can be easily managed from its initial phases, and a control and analysis of the existing situation, foreseeing the possibility of hypothesising but also to calculate and estimate the positive effect of the landscape project on economic, environmental and social sustainability issues, allowing continuous monitoring of nature's dynamism.

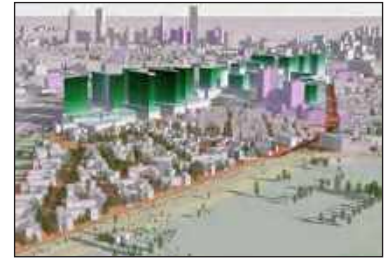
Source: <https://www.landsrl.com/limlandscape-information-modelling>



# Digital Twin (DT)

The first conceptualization of Digital Twin has been made by Michael Grieves in 2003, in the product life cycle management field, where a set of virtual information can describe a potential or real physical manufactured product from micro scale to macro level. More recently Batty (2018), introduce the concept of "Mirror representation" to describe the capacity of Digital Twin to reproduce the physical counterpart into virtual world.

Cities can be reproduced in digital world through data and information collected from the real world about different topics and shape such as transportation, buildings, energy to improve the level of governance and increase the participation of citizens in the design and decision making processes.



## Challenges



Energy sustainability



Temperature regulation



Water management



Health and wellbeing



Transition to circular system

## Objectives



Energy efficiency



Carbon impact



Energy produced from RES



Local microclimate



UHI



Runoff mitigation



Water scarcity



Water quality



Comfort and life quality



Urban space quality



Circular Infrastructures and buildings



Circular Materials and products

## Other benefits



time reduction



increase of efficiency



increase of effectiveness



better governance

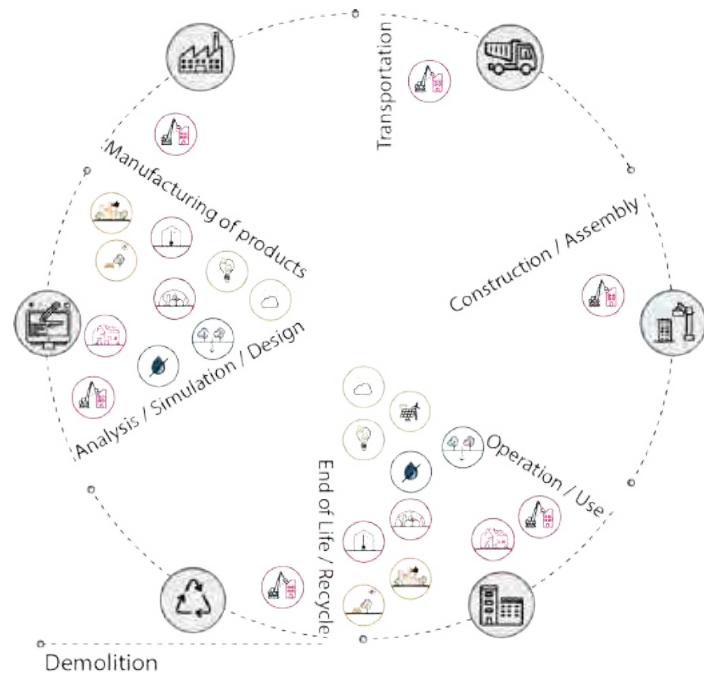


better data management

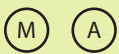


real time monitoring

## DT uses in construction life cycle of Challenges



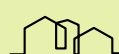
## Strategies



## Scale of application



Building



Neighborhood



City

## Potential linkages with other DTs



BIM



BD



AI



GIS



IoT



Blockchain



AM / RM



MPassport



AR / VR



Digital Platform



DT

## S.D.G.

6.4      11.3      13.1  
11.b      13.2

## Disadvantages

+ Contribution to global warming  
+ long implementation process  
+ high level of complexity  
+ engagement of different disciplines and competences



## Energy sustainability



Digital Twin technology could be applied for different objectives of Energy Consumption challenge. As reported by [1], Digital Twin for Positive Energy District (PED) can accelerate the transition towards a more sustainable society. In Digital Twin platform, other enabling technologies such as sensors, can measure and collect some information related to temperature, moisture, energy consumption, renewable energy production, carbon footprint, CO<sub>2</sub> emissions from building scale to district. Few case studies are involved in recent years considering Energy Consumption challenge, for example in Helsinki, Zurich and Dundalk.



## Temperature regulation

Local Microclimate parameters are assessed in Zurich and Helsinki Digital Twin as reported by [2] focusing in particular on the simulation of future climate scenarios in built environment considering the study of shadows, solar radiation, sunshine hours and ventilation analysis.

In addition some research projects were involved in the last years to study and manage the Urban Heat Island phenomenon, for example Cooling Singapore is a multi-disciplinary research project dedicated to developing solutions to address the urban heat challenge in Singapore, as well as the research conducted by [3] for Qingdao city.

## Water Management



The Urban Digital Twin of Dublin has focused on the development of risk modelling [2] to understand which are the areas at risk in the built environment and to support the local decision making process to avoid these risks.

Some researches have proposed the objectives of water management to intelligent green building to manage waste water and rain water harvesting and re utilization [4] during operational phase, while [5] have proposed a Green Metrics and Digital Twins for Sustainability Planning and Governance of Smart Buildings and Cities to optimize rainwater drainage to avoid soil contamination.



## Health and Wellbeing

There aren't specific application of Digital Twin for the Health and Wellbeing but instead that, Virtual Singapore simulate and model heat and noise map to support local decision making. In addition, Dublin, Zurich and Helsinki can simulate the exposure to pollutants of local inhabitants [2] while Herrenberg has experimented Mobility and traffic simulations for awareness-raising on anthropogenic pollution issues [6].

## Transition to circular system



[1] proposed that Digital Twin Technology applied to Positive Energy Districts model can ensure also the transition of Built Environment to Circular System. In addition, [7] have explored the potential of Digital Twin to extend the service life of building elements through predictive maintenance, to enable the reuse at the building's demolition phase and to remanufacturing of construction waste or to support design reuse. The project "Digital Twin for Circularity" of the Digital Twin Cities Centre underline the potential of this tool to mark property for demolition, to make an inventory of exterior and interior materials, to store information for future buildings and to analyze the re-use and recycled potential of materials.

### References

- [1] Zhang X, Shen J, Saini PK, Lovati M, Han M, Huang P, et al. *Digital Twin for Accelerating Sustainability in Positive Energy District: A Review of Simulation Tools and Applications*. Front Sustain Cities. 2021 Jun 21;3:663269. <https://doi.org/10.3389/frsc.2021.663269>
- [2] Caprari G. *Digital Twin for Urban Planning in the Green Deal Era: A State of the Art and Future Perspectives*. Sustainability. 2022 May 20;14(10):6263. <http://dx.doi.org/10.3390/su14106263>
- [3] Qi Y, Li H, Pang Z, Gao W, Liu C. A Case Study of the Relationship Between Vegetation Coverage and Urban Heat Island in a Coastal City by Applying Digital Twins. Front Plant Sci. 2022 Apr 26;13:861768. <https://doi.org/10.3389/fpls.2022.861768>
- [4] Yang B, Lv Z, Wang F. *Digital Twins for Intelligent Green Buildings*. Buildings. 2022 Jun 19;12(6):856. <https://doi.org/10.3390/buildings12060856>
- [5] Corrado CR, DeLong SM, Holt EG, Hua EY, Tolk A. *Combining Green Metrics and Digital Twins for Sustainability Planning and Governance of Smart Buildings and Cities*. Sustainability. 2022 Oct 11;14(20):12988. <https://doi.org/10.3390/su142012988>
- [6] Dembski F, Wössner U, Letzgas M, Ruddat M, Yamu C. *Urban Digital Twins for Smart Cities and Citizens: The Case Study of Herrenberg, Germany*. Sustainability. 2020 Mar 16;12(6):2307. <https://doi.org/10.3390/su12062307>
- [7] Çetin S, De Wolf C, Bocken N. *Circular Digital Built Environment: An Emerging Framework*. Sustainability. 2021 Jun 3;13(11):6348. <https://doi.org/10.3390/su13116348>



## DT: best practice

### Project name

Kalasadama digital twins  
pilot project

### Year

2019

### Location

Helsinki, Finland

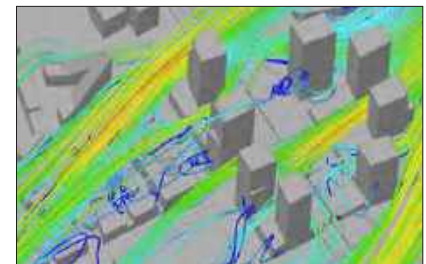


### Energy consumption

The city of Helsinki has developed other dynamic 3D city models, named Energy Atlas platform, that have contribute to simulate energy information, such as information on the energy leakages of buildings, and to educate property owners and citizens about more energy-efficient consumption and carbon neutral behaviour.

### Temperature regulation

The Digital Twin for Kalasadama District has used to design, test and build things digitally firsts before the real development. In this way, some analysis related micro climate conditions has been developed. Wind simulation, wind speed and wind direction were investigated through Ladybug Tols plug-in of Rhinoceros parametric software. Simulations have been made for each month for the reference period (1990). Wind simulations were made using the CityGML city information model and importing it into ANSYS Discovery Live which is capable of performing accurate calculations of air flow behavior with various objects. In addition solar hour analysis and a shadow analysis were carried out simulate micro-climate conditions.



### Other uses and digital applications

The Digital Twin for the Smart District of Kalasadama have been implemented in other uses such as Smart City (traffic and transportation), City Planning (Project Management, Building and Infrastructure Design), Services & Workflow (Business, Innovations & Products), Project Planning (Building permission, decision making and web services) and Communication and Interaction (City Marketing, Tourism and Navigation).

The applications used beyond the analysis for the Energy Consumption and Temperature regulation are measurements and tracking (airflow, noise, visibility, floods and shadows), sensor data (IoT), data integration (big data, open data etc.), Co-operation platforms (feedback, participatory processes) and Simulations (Virtual Reality and Augmented Reality).

### Description

The digital twins in the Kalasadama project in Helsinki offer high quality 3D city models as open data to all operators. The project team hopes that these city model platforms will promote diverse product development, research, teaching and innovation.

The general objective of the project was to produce high quality digital twin city models of the Kalasadama area and to share the models as open data. The models serve as a platform for designing, testing, applying and servicing the entire lifecycle of the built environment. The progress of the project was divided into five intermediate objectives. The general objective of producing the models was the first. The sharing of the 3D city models as open data was the second objective in the project. The third objective was focused on cooperation with the main partner, the Smart Kalasadama project. The fourth objective was to try out the latest ways to model, test and utilize 3D city models. The fifth objective was to promote the exploitation of digital twins in city processes and service production

Source: [https://www.hel.fi/static/liitteet-2019/Kaupunginkanslia/Helsinki3D\\_Kalasadama\\_Digital\\_Twins.pdf](https://www.hel.fi/static/liitteet-2019/Kaupunginkanslia/Helsinki3D_Kalasadama_Digital_Twins.pdf) | Photo credit: -



# Geographic Information System (GIS)

A geographic information system (GIS) is a system that creates, manages, analyzes, and maps all types of data. GIS connects data to a map, integrating location data (where things are) with all types of descriptive information (what things are like there). This provides a foundation for mapping and analysis that is used in science and almost every industry. GIS helps users understand patterns, relationships, and geographic context. The benefits include improved communication and efficiency as well as better management and decision making. Some examples of its applications include cadastral management, disaster monitoring, infrastructure maintenance, and regional planning” (Wang et al., 2019). GIS is also used with BIM for urban data management, energy-efficient building and urban design, optimising the climate requirements of buildings, and tracking supply chain and material flows.



## Challenges

## Objectives

## Other benefits



Energy sustainability



Energy efficiency



Carbon impact



Energy produced from RES



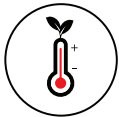
time reduction



increase of efficiency



increase of effectiveness



Temperature regulation



Local microclimate



UHI



better governance



better data management



real time monitoring



Water management



Runoff mitigation



Water scarcity



Water quality



Health and wellbeing



Comfort and life quality



Urban space quality



Transition to circular system



Circular Infrastructures and buildings



Circular Materials and products

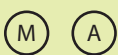
## GIS uses in construction life cycle of Challenges



## Strategies

## Scale of application

## Potential linkages with other DTs



## S.D.G.

## Disadvantages



6.4 11.3 13.1  
11.b 13.2

+ long implementation process  
+ high level of complexity  
+ engagement of different disciplines and competences



## Energy sustainability



GIS can support all the objectives of Energy Sustainability challenge, related to energy efficiency, carbon impact and energy produced by renewable energy systems. In particular [1], have developed a urban energy modelling and energy efficiency scenario based on GIS technology for the city of Turin. They have evaluated the energy performance of existing residential buildings using the energy performance certificate database and have identified the more effective retrofitting interventions by applying an urban-scale energy model. They have measured a significant energy and carbon saving for space heating.



## Temperature regulation

At city and neighborhood scale, GIS plays a key role to support urban planning and urban design decision making process to adapt built environment to the effects of climate change. [2], have assessed the influence of green spaces and Green Mark commercial buildings on Singapore's temperature distribution using non exhaustive factors related to energy consumption and efficiency. In addition the case study have examined the effectiveness of green spaces and commercial buildings in reducing the rate of temperature change. All of these operations were carried out with GIS to promote the goals of urban policies to mitigate urban heat island phenomenon.

## Water Management



Runoff mitigation is one of the main objectives that local administration wants to achieve to adapt built environment to the increase of urban flood events caused by extreme precipitation. [3] have tested a GIS based simulation to understand the variations of flood regulation under different high-intensive urban development scenarios. The analyses were carried out utilizing SWMM (Storm Water Management Model) which is open-source flood inundation simulation approach with the help of GIS in a more qualitative manner. results indicate that expanding built form scenarios increase the flood vulnerability for city functions.



## Health and Wellbeing

[4] underline the potential of GIS tool to support the analysis of indicators identified to develop a framework for Air Quality Management Zones. This research was applied to Antwerp and Gdansk, GIS tool support the calculation and mapping of each indicators involved manage the built environment from the point of view of quality of air. Indicators selected and calculated with GIS are compactness, building height, street pattern, density, gross floor area ratio, street canyon density, height variability, percentage of high vegetation cover, residential and commercial function, vulnerable groups to air pollution and cycling infrastructures, urban parks, and open air facilities.

## Transition to circular system



In the last years GIS has gained some attention in the transition of Built Environment to Circular system to identify, map and manage the resources embedded in building stocks for future reuse or recycling [5]. GIS is also used to support urban mining and industrial symbiosis, from one hand to identify, calculate, and map material stocks in cities and from the other hand to develop a GIS-based supply chain model for industrial symbiosis based on recycled concrete aggregate.

## References

- [1] Mutani G, Todeschi V. *GIS-based urban energy modelling and energy efficiency scenarios using the energy performance certificate database*. Energy Efficiency. 2021 Jun;14(5):47. <https://doi.org/10.1007/s12053-021-09962-z>
- [2] Teo YH, Makani MABH, Wang W, Liu L, Yap JH, Cheong KH. *Urban Heat Island Mitigation: GIS-Based Analysis for a Tropical City Singapore*. IJERPH. 2022 Sep 21;19(19):11917. <https://doi.org/10.3390/ijerph191911917>
- [3] Abenayake C, Jayasinghe A, Wijayawardana N, Kalpana LDCHN, Dias N, Amaratunga D et al. *A GIS-Based Simulation Application to Model Surface Runoff Level in Urban Blocks*. FARU Journal. 2020 Nov 8;7(1):56-64. 7.
- [4] Badach J, Voordeckers D, Nyka L, Van Acker M. *A framework for Air Quality Management Zones - Useful GIS-based tool for urban planning: Case studies in Antwerp and Gdańsk*. Building and Environment. 2020 May;174:106743. <https://doi.org/10.1016/j.buildenv.2020.106743>
- [5] Çetin S, De Wolf C, Bocken N. *Circular Digital Built Environment: An Emerging Framework*. Sustainability. 2021 Jun 3;13(11):6348. <https://doi.org/10.3390/su13116348>





## GIS: best practice

### Project name

Sustainable urban model to new district development with ArcGIS Urban

### Year

2021, ongoing

### Location

Uppsala, Sweden



### Energy Sustainability

The new 3D sustainable development model for new district in Uppsala has supported the development of new district with transit oriented development able to lead the community to carbon neutral city goal. From the transportation point of view, the platform developed with GIS support recharge points for buses powered by renewable energy and biofuel produced from local food waste. New bike lanes and a two-story bike-parking garage next to the train station encourage people to leave their cars at home.

### Health and Wellbeing

The new 3D sustainable development model for new district in Uppsala has supported the development of new district taking into account the outdoor comfort principles and the management of existing natural resources that were not disrupted by the new development but integrated in the open air spaces, such for example the existing trees.



### Other uses and digital applications

Other applications of the new 3D sustainable model of the city of Uppsala were related to transportation and citizen's participation in the planning process of the new city district. The new platform has supported the analysis and design of the rail network and new tramway form the spine of the new city district, matching a growing pattern of urban planning called transit-oriented development that reinforces the value of denser urban pedestrian-oriented areas centered around public transit, and having strong cycling connections.

City technicians were surprised by the very interest of people in the 3D sustainable model. Planners and architects are conducting public consultations according to planning law. The city is at the proposal stage now, and during the spring of 2021, the first detailed planning will take place, which will require another rigorous set of revisions.

### Description

Uppsala city planners set out to create a southeastern city district, through the adoption of data-driven and model-centric approach of geo-design powered by a geographic information system (GIS).

City technicians have tested out cutting-edge techniques and work to find new solutions for becoming more sustainable. The innovative project was developed with the support of two universities in Uppsala, through a close connection with the academic community where we can explore creative and innovative approaches that include new actors and ways to have a smaller climate footprint.

Source: <https://www.esri.com/about/newsroom/blog/uppsala-sustainable-development/>





# Internet of Things (IoT)

As reported by Li et al. (2014), Internet of Things (IoT) can “enables information gathering, storing and transmitting be available for things equipped with the tags or sensors”. Different researchers argue that IoT is constitute by sensors layer able to detect and collect information from physical environment, by network layer for processing and transmitting data acquired by sensors and by application layer that constitute the final field (e.g., transportation, energy etc.) for decision making processes.

IoT has contributed to expand the Smart City paradigm in the last years, in order to support city operations with minimal human interventions. Some key components that can differ from each city are smart energy grids, smart communities, smart healthcare and smart transportation.



## Challenges



Energy sustainability



Temperature regulation



Water management



Health and wellbeing



Transition to circular system

## Objectives



Energy efficiency



Carbon impact



Energy produced from RES



Local microclimate



UHI



Runoff mitigation



Water scarcity



Water quality



Comfort and life quality



Urban space quality



Circular Infrastructures and buildings



Circular Materials and products

## Other benefits



time reduction



increase of efficiency



increase of effectiveness



better governance

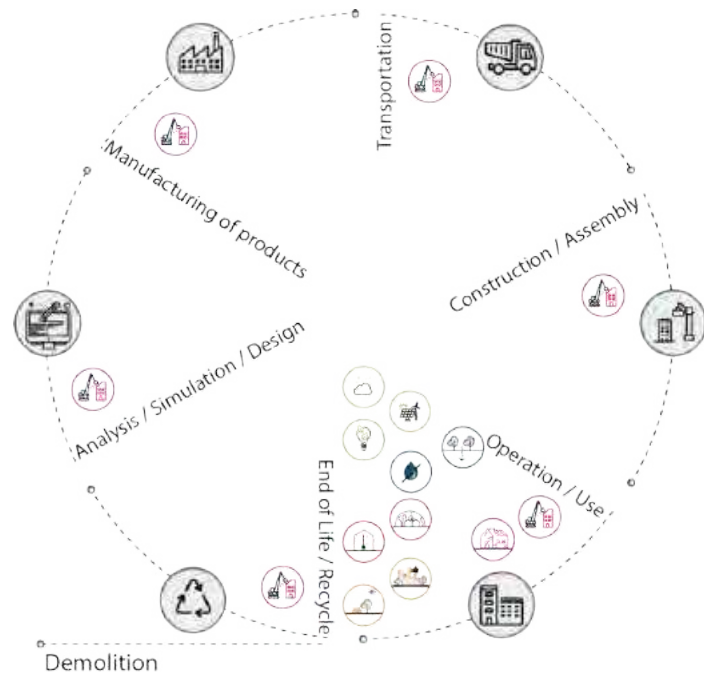


better data management



real time monitoring

## IoT uses in construction life cycle of Challenges



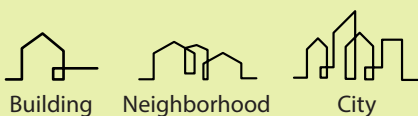
## Strategies



## S.D.G.

6.4 11.3 13.1  
11.b 13.2

## Scale of application



## Disadvantages

+ Contribution to global warming  
+ long implementation process  
+ high level of complexity  
+ engagement of different disciplines and competences

## Potential linkages with other DTs



## Energy sustainability



IoT technology could be applied for different objectives of Energy Sustainability challenge. We can find IoT in different scale, at building scale Smart Metering and Environment Monitoring have increased knowledge on how buildings perform [1] and also Building Energy Management System (BEMS) used a network of sensors in all the environments [1]. The IoT is one of the main key technologies to enable Smart City concept towards the needs of improve energy efficiency of various city components, such as applications in smart Grids, Smart Homes, Smart Street Lights and Smart Parking [2]



## Temperature regulation

Urban Heat Island effect could be also studied through the application of IoT in temperature monitoring and development of prediction system [3]. 3M/Air project aims to explore the potential of participatory citizen measures using low-cost sensors in order to improve the local knowledge of air quality and temperature and then bridge the gap between individual exposure and regional measurements [4]

## Water management



An example of IoT applied in Built Environment to support the Water Management challenge is Polder Roof [5], where sensors can contribute to measures and regulates the rain-water collected on the rooftop in a green roof system.



## Health and wellbeing

There are some case studies that used IoT in smart buildings to monitor the indoor environment. Interact [6] is a system that collects data and information from IoT sensors incorporated in lighting systems and provides some information to support the sustainable building operations. The Edge smart office Building [7] use the IoT benefits to increase the health and wellbeing of indoor environment by controlling heating, ventilation and space conditioning systems.

## Transition to circular system



[8] have explored the potential of IoT for the physical and digital traceability of building elements in different construction lifecycle step. This potential was enhanced with the integration of RFID. [9] explore the use of IoT embedded in construction materials of distributed manufacturing of modular homes in which information flow is collected through each life cycle step.

## References

- [1] Matteo Giovanardi, Matteo Trane, Riccardo Pollo. *IoT in Building Process: A Literature Review*. JCEA [Internet]. 2021 Sep 28 [cited 2022 Oct 13];15(9). Available from: <http://www.davidpublisher.com/index.php/Home/Article/index?id=46455.html>
- [2] Al-Obaidi KM, Hossain M, Alduais NAM, Al-Duais HS, Omrany H, Ghaffarianhoseini A. *A Review of Using IoT for Energy Efficient Buildings and Cities: A Built Environment Perspective*. Energies. 2022 Aug 18;15(16):5991. <https://doi.org/10.3390/en15165991>
- [3] Hidayat DJ, Soekirno S. *Development of temperature monitoring and prediction system for urban heat island (UHI) based on the internet of things*. J Phys: Conf Ser. 2021 Feb 1;1816(1):012054. <https://doi.org/10.1088/1742-6596/1816/1/012054>
- [4] Fekih MA, Bechkit W, Rivano H, Dahan M, Renard F, Alonso L, et al. *Participatory Air Quality and Urban Heat Islands Monitoring System*. IEEE Trans Instrum Meas. 2021;70:1–14. <https://doi.org/10.1109/TIM.2020.3034987>
- [5] We harvest urban rainwater [Internet]. MetroPolder company. 2022 [cited 2022Nov10]. Available from: <https://metropolder.com/en/#polderroof>
- [6] Unlock the extraordinary potential of IoT lighting [Internet]. Interact IoT lighting company. 2022 [cited 2022Nov10]. Available from: <https://www.interact-lighting.com/global>
- [7] The Edge Smart Building Amsterdam [Internet]. The EDGE Olympic. 2022 [cited 2022Nov10]. Available from: <https://edge.tech/developments/the-edge>
- [8] Çetin S, De Wolf C, Bocken N. *Circular Digital Built Environment: An Emerging Framework*. Sustainability. 2021 Jun 3;13(11):6348. <https://doi.org/10.3390/su13116348>
- [9] Turner C, Oyekan J, Stergioulas LK. *Distributed Manufacturing: A New Digital Framework for Sustainable Modular Construction*. Sustainability. 2021 Feb 1;13(3):1515. <https://doi.org/10.3390/su13031515>



## IoT: best practice

### Project name

Polder Roof®+ Smartroof 2.0

### Year

2018

### Location

Amsterdam

### Water Management

The aim of the start-up Metro Polder is to make cities future-proof, by applying smart water management. Think of reusing rainwater or for cooling cities to combat heat stress.

The blue-green roofs conceptualized and realized by Metro Polder are equipped with a buffer system, an internet-connected valve and an online dashboard. The valves sensors and rain radars control the water level and discharge real-time. This smart connection enables dynamic water storage. A proven effective technology that has been implemented in projects in several locations worldwide, including the Netherlands, Guatemala, United States, France and the United Kingdom.

### Temperature regulation

The aim of Smart Roof 2.0 research is to investigate the effect of water availability on actual evaporation (Ea) and the distribution of energy between the latent heat flux (LE) and the sensible heat flux (H) in a rooftop environment in Amsterdam, the Netherlands. Researchers have compared the water and energy balance of conventional green roofs and (blue-)green roofs equipped with a novel water storage and a passive capillary irrigation system. Research group have measured actual evaporation on-site using sensitive custom build weighing lysimeters integrated in the green roof over one year. We provide quantitative insights and practical modeling procedures to assess the success of different roof types in evaporating and storing rainwater and potentially cooling the air to mitigate the UHI phenomenon.



### Other uses and digital applications

Other uses of smart green-blue roof could be met in other pilot project realized by Metro Polder such as B. Bylon also built in Amsterdam. B. Bylon is an edible roof terrace, or Roof Park, on office concept B. Amsterdam is an impressive 1500m<sup>2</sup> park. It is the first of its kind and extremely versatile. On the roof you will find a water feature, two pétanque courts, a large vegetable garden, fruit trees and a chicken coop. There is an out-door seating area as well as covered office spaces with hammocks for meetings; you will even find two decorative Trabant cars on this roof.

### Description

On the Marineterrein in Amsterdam, the roof of one of the buildings used to conduct detailed research into the evaporation of blue-green roofs. The effects of different substrate thicknesses and water buffering are compared with each other. Results of this research show that water availability is a condition for enhanced cooling and biodiversity on green roofs. In practice, the PolderRoof worked so well that the air conditioners for the poorly insulated top floor were not necessary during the hot summer of 2018.

Source: <https://metropolder.com/projecten/smartroof-2-0-2/>

## References

- ARUP (2016). *The Circular Economy in the Built Environment*. London: Arup.
- Bahrami, A.F.; Leili, M.; Vaziri, Y.; Salahshour, A.S.; Cristaldi, A.; Oliveri Conti, G.; Ferrante, M. Health impacts quantification of ambient air pollutants using AirQ model approach in Hamadan, Iran. *Environ. Res.* 2018, 161, 114–121.
- Biddle, S., & Seymour, M. (2012). Healthy neighbourhoods and communities: Policy and practice. *Health promotion settings: Principles and practice*, 92-109.
- Campbell-Johnston, K., Cate, J. ten, Elfering-Petrovic, M., & Gupta, J. (2019). City level circular transitions: Barriers and limits in Amsterdam, Utrecht and The Hague. *Journal of Cleaner Production*, 235, 1232–1239. <https://doi.org/10.1016/j.jclepro.2019.06.106>
- Capolongo, S., Rebecchi, A., Dettori, M., Appolloni, L., Azara, A., Buffoli, M., ... & D'Alessandro, D. (2018). Healthy design and urban planning strategies, actions, and policy to achieve salutogenic cities. *International Journal of Environmental Research and Public Health*, 15(12), 2698.
- Cedeño, L.J.G.; Williams, A.; Oulhote, Y.; Zanobetti, A.; Allen, J.G.; Spengler, J.D. Reduced cognitive function during a heat wave among residents of non-air-conditioned buildings: An observational study of young adults in the summer of 2016. *PLoS Med.* 2018, 15, e1002605
- Charlesworth, S. M. (2010). A review of the adaptation and mitigation of global climate change using sustainable drainage in cities. *Journal of Water and Climate Change*, 1(3), 165–180. <https://doi.org/10.2166/wcc.2010.035>
- Charlesworth, S.M. and Booth C. A. (eds.) (2017). *Sustainable Surface Water Management: a Handbook for SUDS*, Wiley Blackwell, Oxford.
- Çetin, S., De Wolf, C., & Bocken, N. (2021). Circular Digital Built Environment: An Emerging Framework. *Sustainability*, 13(11), 6348. <https://doi.org/10.3390/su13116348>
- Croce, S., & Vettorato, D. (2021). Urban surface uses for climate resilient and sustainable cities: A catalogue of solutions. *Sustainable Cities and Society*, 75, 103313.
- De Filippi, F. & Carbone, C. (2021). Le ICT a supporto della progettazione circolare in ambito urbano. *TECHNE: Journal of Technology for Architecture & Environment*. (22), p96-103. <https://doi.org/10.36253/techne-10610>
- Demuzere, M., Orru, K., Heidrich, O., Olazabal, E., Geneletti, D., Orru, H., Bhave, A. G., Mittal, N., Feliu, E., & Faehnle, M. (2014). Mitigating and adapting to climate change: Multi-functional and multi-scale assessment of green urban infrastructure. *Journal of Environmental Management*, 146, 107–115. <https://doi.org/10.1016/j.jenvman.2014.07.025>
- D'Olimpio, D. (2017). Il retrofitting energetico e bioclimatico nella riqualificazione edilizia: Tecnologie e soluzioni tecniche per il miglioramento della prestazione energetico-ambientale degli edifici. *Legislazione tecnica*.
- European Commission. A Clean Planet for all. A European long-term strategic vision for a prosperous, modern, competitive and climate neutral economy. Com(2018) 773 2018:25.
- European Commission. A new Circular Economy Action Plan for a cleaner and more competitive Europe. Luxembourg: Office for Official Publications of the European Communities; 2020.
- European Commission (2020). *EU Circular Economy Action Plan*. [https://environment.ec.europa.eu/strategy/circular-economy-action-plan\\_en](https://environment.ec.europa.eu/strategy/circular-economy-action-plan_en)



European Commission (2021). *Europe's Digital Decade: Commission Sets the Course Towards a Digitally Empowered Europe by 2030*. [https://ec.europa.eu/commission/presscorner/detail/en/IP\\_21\\_983](https://ec.europa.eu/commission/presscorner/detail/en/IP_21_983)

European Commission. Forging a climate-resilient Europe - the new EU Strategy on Adaptation to Climate Change. Luxembourg: Office for Official Publications of the European Communities; 2021.

European Union. New European Bauhaus [Internet]. About the initiative; 2020 [updated 2022; cited 2022 Nov 21]. Available from: [https://new-european-bauhaus.europa.eu/about/about-initiative\\_en](https://new-european-bauhaus.europa.eu/about/about-initiative_en)

Eurostat (2020). *Waste Statistics*. [https://ec.europa.eu/eurostat/statistics-explained/index.php/Waste\\_statistics#Total\\_waste\\_generation](https://ec.europa.eu/eurostat/statistics-explained/index.php/Waste_statistics#Total_waste_generation)

Garshasbi, S., Haddad, S., Paolini, R., Santamouris, M., Papangelis, G., Dandou, A., Methymaki, G., Portalakis, P., & Tombrou, M. (2020). Urban mitigation and building adaptation to minimize the future cooling energy needs. *Solar Energy*, 204, 708–719. <https://doi.org/10.1016/j.solener.2020.04.089>

Herczeg, M.; McKinnon, D.; Milios, L.; Bakas, I.; Klaassens, E.; Svatikova, K.; Widerberg, O. (2014). *Resource Efficiency in the Building Sector*. European Commission, DG Environment.

IPCC (2018). Summary for Policymakers. In: *Global Warming of 1.5°C. An IPCC Special Report on the impacts of global warming of 1.5°C above pre-industrial levels and related global greenhouse gas emission pathways, in the context of strengthening the global response to the threat of climate change, sustainable development, and efforts to eradicate poverty* [Masson-Delmotte, V., P. Zhai, H.-O. Pörtner, D. Roberts, J. Skea, P.R. Shukla, A. Pirani, W. Moufouma-Okia, C. Péan, R. Pidcock, S. Connors, J.B.R. Matthews, Y. Chen, X. Zhou, M.I. Gomis, E. Lonnoy, T. Maycock, M. Tignor, and T. Waterfield (eds.)]. Cambridge University Press, Cambridge, UK and New York, NY, USA, pp. 3-24. <https://doi.org/10.1017/9781009157940.001>

JPI Urban Europe, Positive Energy Districts (PED). Available online: <https://jpi-urbaneurope.eu/ped/> (accessed on 24 October 2022).

Khaniabadi, Y.O.; Fanelli, R.; DeMarco, A.; Daryanoosh, S.M.; Kloog, I.; Hopke, P.K.; Oliveri Conti, G.; Ferrante, M.; Mohammadi, M.J.; Babaei, A.A.; et al. Hospital admissions in Iran for cardiovascular and respiratory diseases attributed to the Middle Eastern Dust storms. *Environ. Sci. Pollut. Res. Int.* 2017, 24, 16860–16868.

Kleerekoper, L., Van Esch, M., & Salcedo, T. B. (2012). How to make a city climate-proof, addressing the urban heat island effect? *Resources, Conservation and Recycling*, 64, 30-38.

Lai, D., Liu, W., Gan, T., Liu, K., & Chen, Q. (2019). A review of mitigating strategies to improve the thermal environment and thermal comfort in urban outdoor spaces. *Science of the Total Environment*, 661, 337-353.

Lindström, B., & Eriksson, M. (2011). From health education to healthy learning: Implementing salutogenesis in educational science. *Scandinavian journal of public health*, 39(6\_suppl), 85-92.

Lollini, R., Pasut, W. et al (2020). Regenerative technologies for the indoor environment: Inspirational guidelines for practitioners. COST Action, CA16114 RESTORE, Working Group Four Report.

Maass, R., Lillefjell, M., & Espnes, G. A. (2017). The application of Salutogenesis in cities and towns. *The handbook of salutogenesis*, 171-179.

Marmot, M., Allen, J., Goldblatt, P., Boyce, T., McNeish, D., Grady, M., et al. (2010). *Fair society, healthy lives: Strategic review of health inequalities in England post-2010*. The Marmot Review, London, UK.

Marselle, M. R., Stadler, J., Korn, H., Irvine, K. N., & Bonn, A. (2019). Biodiversity and health in the face of climate change (p. 481). Springer Nature.

Mauree, D., Naboni, E., Coccolo, S., Perera, A. T. D., Nik, V. M., & Scartezzini, J. L. (2019). A review of assessment methods for the urban environment and its energy sustainability to guarantee climate adaptation of future cities. *Renewable and Sustainable Energy Reviews*, 112, 733-746.



- McKnight, J., & Block, P. (2011). *The abundant community: Awakening the power of families and neighborhoods*. ReadHowYouWant. com.
- Naboni, E., Natanian, J., Brizzi, G., Florio, P., Chokhachian, A., Galanos, T., & Rastogi, P. (2019). A digital workflow to quantify regenerative urban design in the context of a changing climate. *Renewable and Sustainable Energy Reviews*, 113, 109255.
- Natanian, J., & Auer, T. (2020). Beyond nearly zero energy urban design: A holistic microclimatic energy and environmental quality evaluation workflow. *Sustainable Cities and Society*, 56. <https://doi.org/10.1016/j.scs.2020.102094>
- Nikolopoulou, M., & Lykoudis, S. (2007). Use of outdoor spaces and microclimate in a Mediterranean urban area. *Building and environment*, 42(10), 3691-3707.
- Oberndorfer, E., Lundholm, J., Bass, B., Coffman, R. R., Doshi, H., Dunnett, N., Gaffin, S., Köhler, M., Liu, K. K. Y., & Rowe, B. (2007). Green roofs as urban ecosystems: Ecological structures, functions, and services. In *BioScience* (Vol. 57, Issue 10, pp. 823–833). <https://doi.org/10.1641/B571005>
- Oke, T. R. (2002). *Boundary layer climates*. Routledge.
- Pisello, A. L. (2017). State of the art on the development of cool coatings for buildings and cities. In *Solar Energy* (Vol. 144, pp. 660–680). Elsevier Ltd. <https://doi.org/10.1016/j.solener.2017.01.068>
- Raven, J., Stone, B., Mills, G., Towers, J., Katzschner, L., Leone, M., Gaborit, P., Georgescu, M., & Hariri, M. (2018). *Urban planning and design*. Cambridge University Press.
- Rittel, K., Bredow, L., Wanka, E. R., Hokema, D., Schuppe, G., Wilke, T., ... & Heiland, S. R&D Project FKZ 3511 82 800 Federal Agency for Nature Conservation Green, natural, healthy: The potential of multifunctional urban spaces.
- Robinson, D. (2005). The search for community cohesion: Key themes and dominant concepts of the public policy agenda. *Urban studies*, 42(8), 1411-1427.
- Saheb, Y., Shnapp, S. and Paci, D., *From nearly-zero energy buildings to net-zero energy districts - Lessons learned from existing EU projects*, EUR 29734 EN, Publications Office of the European Union, Luxembourg, 2019, ISBN 978-92-76-02915-1, doi:10.2760/693662, JRC115188.
- Taleghani, M. (2018). Outdoor thermal comfort by different heat mitigation strategies- A review. *Renewable and Sustainable Energy Reviews*, 81(P2), 2011–2018. <https://EconPapers.repec.org/RePEc:eee:rensus:v:81:y:2018:i:p2:p:2011-2018>
- Santamouris, M. (2013). Using cool pavements as a mitigation strategy to fight urban heat island—A review of the actual developments. *Renewable and Sustainable Energy Reviews*, 26, 224-240.
- Scrivener, K. (2020, October 10). *A concrete idea to reduce carbon emissions*. Ted Talk. [https://www.ted.com/talks/karen\\_scrivener\\_a\\_concrete\\_idea\\_to\\_reduce\\_carbon\\_emissions](https://www.ted.com/talks/karen_scrivener_a_concrete_idea_to_reduce_carbon_emissions)
- Vaandrager, L., & Kennedy, L. (2017). The application of salutogenesis in communities and neighborhoods. *The handbook of salutogenesis*, 159-170.
- Vera, E., Cameron, B. and D. P. and G. D. and M. G. and P. U. (2017). Nature-Based Solutions and Buildings – The Power of Surfaces to Help Cities Adapt to Climate Change and to Deliver Biodiversity. In H. and S. J. and B. A. Kabisch Nadja and Korn (Ed.), *Nature-Based Solutions to Climate Change Adaptation in Urban Areas: Linkages between Science, Policy and Practice* (pp. 159–183). Springer International Publishing. [https://doi.org/10.1007/978-3-319-56091-5\\_10](https://doi.org/10.1007/978-3-319-56091-5_10)
- World Health Organization. (2012). *Addressing the social determinants of health: the urban dimension and the role of local government*. World Health Organization. Regional Office for Europe.

WHO & CBD (2015) Connecting global priorities: biodiversity and human health. A state of the knowledge review. World Health Organization & Secretariat of the Convention on Biological Diversity.  
<https://www.cbd.int/health/SOK-biodiversity-en.pdf>. Accessed 24 October 2022

Woods Ballard, B. (Bridget), & Construction Industry Research and Information Association (2015). The SuDS manual. CIRIA.

## Glossary of Terms





BT	Building Technologies
BI	Blue Infrastructure
BIPV/BAPV	Building-Integrated Photovoltaics /Building Applied Photovoltaics
CO2	Carbon Dioxide
CPCC	Climate Positive Circular Communities
ES	Energy Sustainability
ES	Energy systems
EU	European Union
GHG	GreenHouse Gases
H/W	height-to-width ratio
HW	Health and wellbeing
PED	Positive Energy Districts
RES	Renewable Energy Sources
S	Shading devices
SPEN	Sustainable Plus Energy Neighborhoods
SUDS	Sustainable Urban Drainage Systems
SVF	sky view factor
SWM	Sustainable Water Management
TCS	Transition to Circular System
TR	Temperature Regulation
UGI	Urban Green Infrastructure
ZEN	Zero Emission Neighborhoods

## Legend icons & symbols















### Challenges

-  Energy sustainability
-  Temperature regulation
-  Water management
-  Health and wellbeing
-  Transition to digital system




















### Objectives

-  Energy demand
-  Carbon impact
-  Energy produced from RES
-  Local microclimate
-  UHI
-  Run off mitigation
-  Water scarcity
-  Water quality
-  Comfort and life quality
-  Urban space quality
-  Infrastructure and buildings
-  Materials and Products

### Performances

-  Energy from RES on site
-  Low carbon material use
-  Greening
-  Energy efficiency
-  Temperature surface/air
-  Outdoor thermal comfort
-  Shadow effect
-  Water retention
-  Water storage and reuse
-  Water treatment
-  Green space
-  Space for socialization
-  Air quality
-  Walkability

### Other benefits

-  Artistic expression
-  Biodiversity
-  Cooling costs
-  Cooling effect
-  Const temperature
-  Easy to repair
-  Fire resistant
-  Flexibility
-  Food production
-  Glare
-  Heat gain
-  Indoor thermal comfort
-  Integration
-  Lifespan/Reuse
-  Lighting costs
-  Mold and condensation
-  Noise pollution
-  Privacy
-  Storage
-  Thermal insulation
-  UV rays
-  Weather protection

## **Acknowledgements and disclaimer**

We thank all those who contributed directly and indirectly to the construction of this catalogue in terms of material collection, content and work development.





CLIMATE POSITIVE CIRCULAR COMMUNITIES

## **ANNEX**

### **9.2 Natural and mechanical ventilation in climate responsive and net-positive energy buildings**

**D4.5 DESIGN GUIDELINES OF CLIMATE POSITIVE CIRCULAR COMMUNITY IN TRENTO**

**WP4 SUSTAINABLE BUILDING (RE) DESIGN**

# Natural and mechanical ventilation in climate responsive and net-positive energy buildings

Authors:

Luca Zaniboni (UNITN) – [luca.zaniboni@unitn.it](mailto:luca.zaniboni@unitn.it)

Rossano Albatici (UNITN) – [rossano.albatici@unitn.it](mailto:rossano.albatici@unitn.it)

## Index

<b>1. Climate responsive and net-positive energy buildings: definitions</b>	.....
<b>2. Natural ventilation principles in climate responsive and energy positive buildings</b>	.....
<b>2.1 Wind induced natural ventilation</b>	.....
2.1.1 Fenestration: single-sided ventilation	.....
2.1.2 Fenestration: cross ventilation	.....
2.1.3 Wind tower / Wind catcher	.....
2.1.4 Wing walls	.....
2.1.5 Deflection by edges	.....
2.1.6 Wind cowls / Scoops	.....
2.1.7 Rotating wind cowl, turbine ventilators, exhaust cowls, roof vents, roof cowls	.....
2.1.8 Ventilation openings in the façade	.....
2.1.9 Embedded ducts, ventilation chambers	.....
<b>2.2 Buoyancy driven natural ventilation</b>	.....
2.2.1 Stack ventilation	.....
2.2.2 Double skin façade (Vent-skin walls)	.....
2.2.3 Trombe wall	.....
2.2.4 Solar (thermal) chimney / Roof solar chimney	.....
2.2.5 Solar façades (e.g. unglazed transpired solar façade and glazed transpired solar façade)	.....
2.2.6 Atrium	.....
<b>2.3 Main ways to exploit natural ventilation</b>	.....
2.3.1 Air change	.....
2.3.2 Thermal regulation	.....
2.3.3 Night cooling	.....
<b>2.4 Standards and guidelines for NV</b>	.....
<b>3. Mechanical ventilation principles in climate responsive energy positive buildings</b>	.....
<b>3.1 Overview of Heat Recovery Ventilation (HRV) functioning</b>	.....
<b>3.2 Standards and guidelines for MV</b>	.....
<b>4. Hybrid ventilation principles in climate responsive energy positive buildings</b>	.....
<b>5. Natural, mechanical and hybrid ventilation with a double perspective focusing on both energy consumption and indoor well-being</b>	.....
<b>5.1 Methodology</b>	.....
<b>5.2 Results</b>	.....
5.2.1 Studies suggesting the use of NV	.....
5.2.2 Studies suggesting the use of MV	.....
5.2.3 Studies suggesting the use of HV or both NV and HV	.....
5.2.4 Studies not clearly stating a preference	.....
<b>5.3 Further statistics about literature analysis</b>	.....
<b>5.4 Main literature analysis outcomes</b>	.....
<b>6. References</b>	.....

## 1. Climate responsive and net-positive energy buildings: definitions

In the framework of research and practice within the field of building design, the aim of **responsive architecture** is to make the buildings able to adapt their shape, color, form or character (by means of actuators) using sensors' measurements of environmental conditions. In this way, responsive technologies such as control systems, sensors and actuators can be used to improve buildings' energy performance. This technique is distinguished from other forms of interactive building design, since smart and responsive technologies are embodied in building's fabric core elements, thus allowing, for instance, to connect the shape of the facility to the environment where it is located [1]–[6]. In practice, climatic responsive design uses weather data (e.g., wind, sun, humidity and rainfall) to create a building structure reflecting the weather conditions of the peculiar area where the building is located [7]. Some examples of applied climate responsive architecture are reported in Figures Figure 1 -Figure 2Figure 3.

**Net-positive energy buildings (nPEBs)** can be defined as ones that, on annual average, produce more renewable energy than they import from external sources. As Hu (2016) highlights “this is achieved using a combination of small power generators and low-energy building techniques, such as passive solar building design, insulation and careful site selection and placement” [8], [9]. In practice, many technologies and principles of net-zero energy buildings (nZEBs) are followed, with new district/network and alternative energy resources (instead than renewable) perspectives. Several techniques can be used to maximize the energy production and minimize the energy consumption in nPEB and nZEB, including: improved levels of building insulation, high performance glazing, daylight, efficient HVAC (Heating, Ventilation and Air Conditioning) systems (e.g. heat pumps and exhaust energy recovery), high efficiency lighting and control, natural ventilation and thermal regulation through thermal mass [8], [10], [11]. Examples of buildings exploiting these solutions are reported in Figure 4 and Figure 5.



Figure 1: “Ecobulevar de Vallecas” in Madrid (Spain). Built from recycled plants and materials, the building is able to lower the temperature by up to 10 °C by mimicking a greenhouse system [7], [12]



Figure 2: “Caixaforum Vertical Garden” in Madrid (Spain). 250 species of plants grow on a 460 square meters vertical garden, contributing in creating indoor and outdoor thermal comfort conditions [7], [13]



Figure 3: “Abu Dhabi Central Market” (United Arab Emirates, UAE). Resembling the traditional Islamic art of coffered roofs, the covering is able to adapt to different sunlight conditions, with natural cooling when allowed by outside conditions [7], [14]



Figure 4: “Sustainable Energy Fund Office Building” in Schnecksville (Pennsylvania, USA). The building orientation and windows’ design allows to take advantage from shade, sun and daylight, minimizing the loss of energy. It also uses a roof photovoltaic array. It is planned to generate 130 % of the required energy [15]





Figure 5: “2226” in Lustenau (Austria). The office building does not use energy sources different than internal gains or solar gains, being able to always maintain a temperature comprised between 22 °C and 26 °C by means of construction techniques, night cooling by means of natural ventilation, proper use of thermal mass and sensors’ support [10], [11], [16]

## 2. Natural ventilation principles in climate responsive and energy positive buildings

By definition, **natural ventilation (NV)** relies on natural forces. For this reason, it is considered one as one of the main techniques to lower buildings’ energy consumption [17]. Moreover, NV was observed to significantly enlarge the acceptable range of indoor thermal comfort, with respect to mechanical ventilation (MV) systems [18]. This led to the modification of ASHRAE Standard 55 [19], which introduced adaptive model for naturally ventilated buildings, beside the steady state *PMV-PPD* model from Fanger [20]. This allowed the possibility to accept an increase of indoor temperature when outdoor temperature is higher. Moreover, it was observed that NV also led to benefits related with symptoms associated with Sick Building Syndrome, satisfaction with the environment, productivity and job satisfaction [17], [21].

For these reasons, it is clear that NV techniques are worth to be analyzed in the framework of climate responsive and net positive energy buildings. For instance, eleven glass towers will be incorporated in Masdar Headquarters in Abu Dhabi, in order to achieve carbon neutrality firstly, and even energy generation later (Figure 6 -Figure 7Figure 8) [22], [23].

The natural forces used by NV are of two types: (1) wind coming from the outdoor environment and (2) buoyancy forces formed by gradients of temperature inside building [17]. Efficiency of NV depends on building’s architectural and location characteristics, such as spacing and arrangements, building orientation, landscaping and size of openings [24].

Following subsections explore different techniques of NV, grouped according to the driving forces they exploit. Examples of real buildings using the techniques are also included. Main purposes NV can be used for and some guidelines to be consulted for developing NV in buildings are also listed.

It is important to highlight that more than one technique (and driving force) can be used in the same building.





Figure 6: Rendering of Masdar Headquarters in Abu Dhabi (UAE) [23]

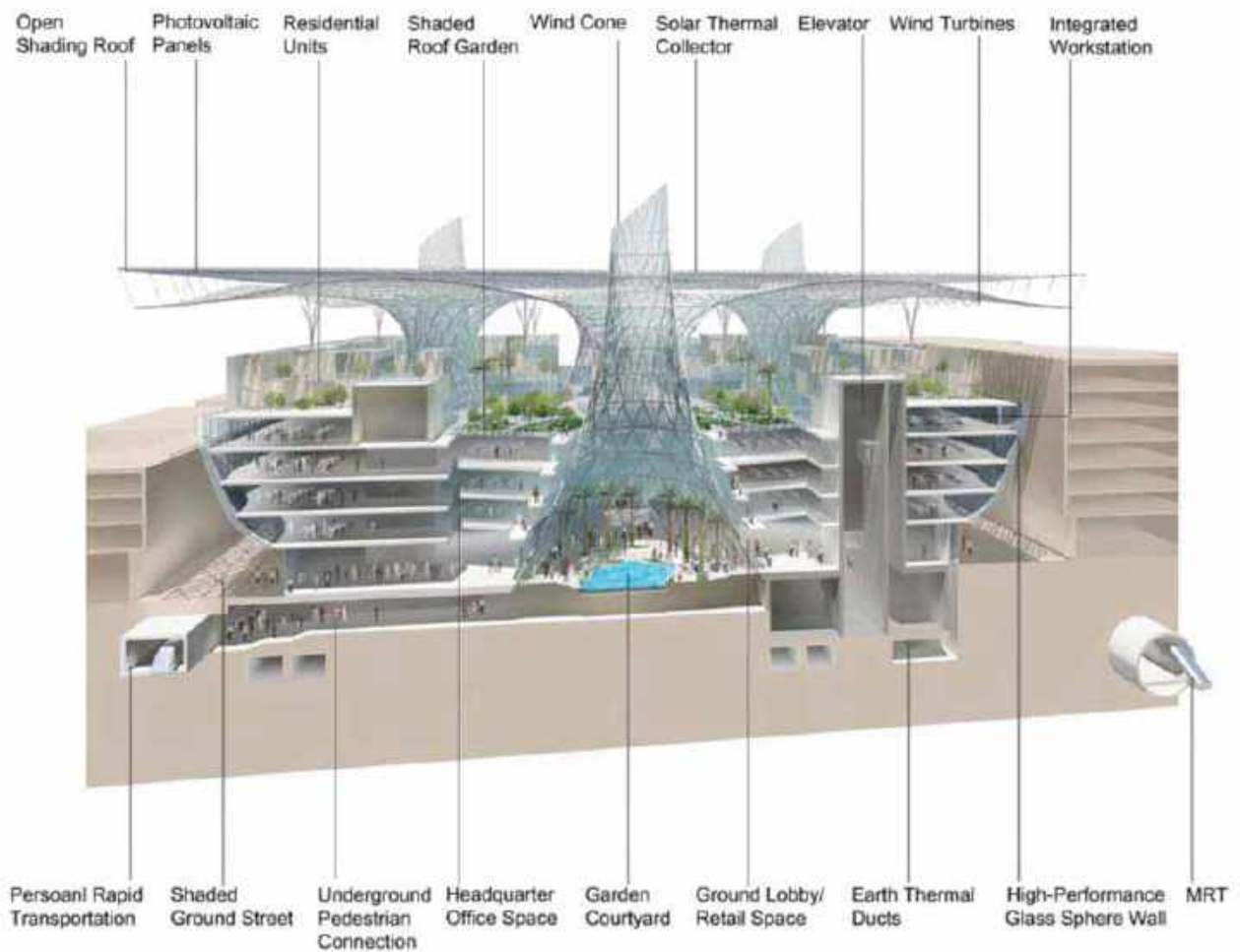


Figure 7: Section of Masdar Headquarter (Abu Dhabi, UAE) with different sustainability strategies, including wind towers [23]

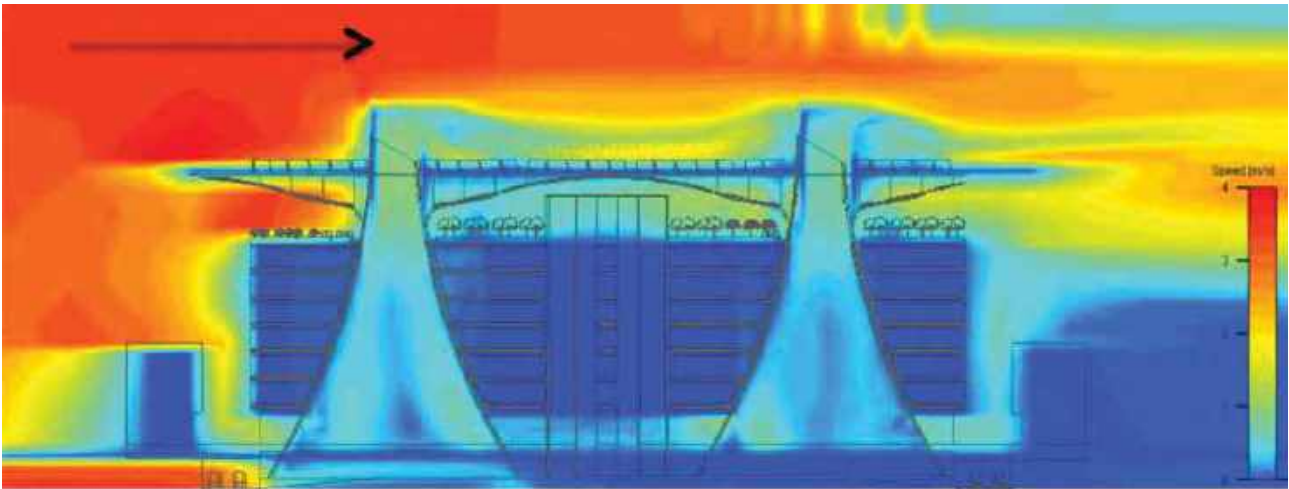


Figure 8: Section of Masdar Headquarters (Abu Dhabi, UAE) - natural ventilation through wind towers: Computational Fluid Dynamics [23]

## 2.1 Wind induced natural ventilation

This NV technique is driven by a difference of pressure between the windward and the leeward side of a building, resulting in an air movement due to the pressure gradient (Figure 9) [24]–[30]. It is important to remark that architectonic solutions for wind induced NV (listed below) can also be exploited for buoyancy driven NV, even if some further attentions might be needed (i.e. windows or openings at different heights to take advantage of convection).

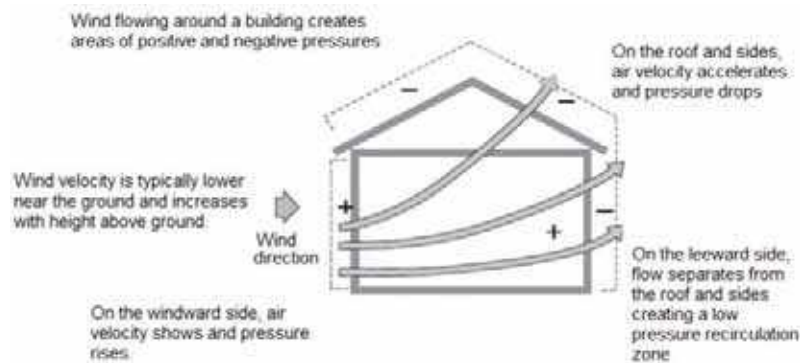


Figure 9: Mechanism of wind induced natural ventilation [24]

### 2.1.1 Fenestration: single-sided ventilation

This type of NV is produced through one or more openings on the same side (wall) of an enclosed indoor space. Ventilation is mainly driven by turbulence. It is the most simple technique, but low ventilation rates and airflow depth penetration are induced. The ventilation rate can be increased by stack effect if more than one opening at different heights are present [24]–[30].

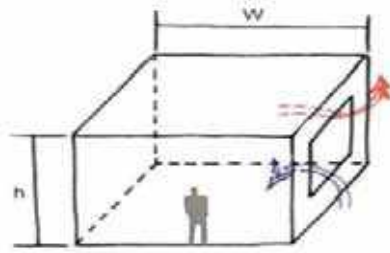


Figure 10: Single-sided ventilation [24]



Figure 11: Bauhaus (Dessau-Roßlau) – lined up windows operated by one unique joint actuator [25]

### 2.1.2 Fenestration: cross ventilation

This NV technique is driven by airflow entering an indoor space from an opening on one side (windward wall), and leaving from another side (leeward wall). Consistent airflow and deep air penetration can be achieved. An additional buoyancy effect can be produced if intake and outtake openings are located at different heights. Nevertheless, uncomfortable drafts might be produced by inappropriate windows' design [24]–[30].

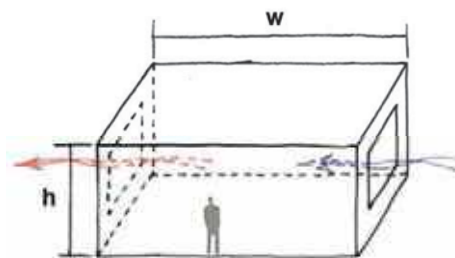


Figure 12: Cross ventilation [24]

### 2.1.3 Wind tower / Wind catcher

Being located next to the roof or as separate structures, they are designed to cool and circulate air by means of prevailing summer winds. Having several openings on different sides, they can work as inlets and outlets at the same time. They can be used together with wind scoops (see Paragraph 2.1.6), with the latter working as inlets. More air flow can be produced collecting and extracting air at higher levels [24]–[30].

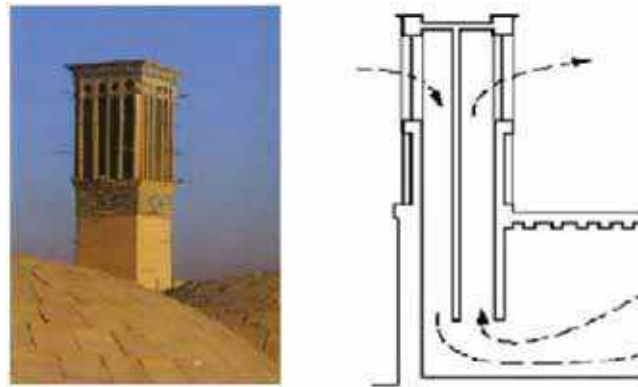


Figure 13: Wind tower [24]



Figure 14: Yazd (Iran) – traditional wind towers [25]

### 2.1.4 Wing walls

Wing walls are used to increase efficiency of NV, especially with single-sided NV and on sites with variable direction and/or low velocity of external wind. Constructive elements are used to increase the pressure gradient between inflow and outflow of air [24]–[30].



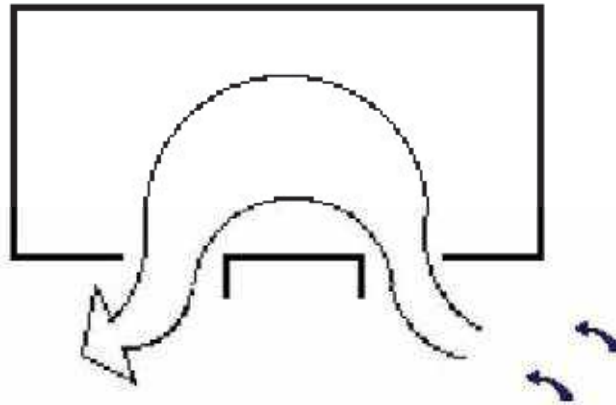


Figure 15: Wing walls [24]

### 2.1.5 Deflection by edges

This constructive technique is also used to improve the air-change, by means of deflection of the prevailing wind direction [24]–[30].



Figure 16: Example of a 90° deflection obtained by edges [24]

### 2.1.6 Wind cowls / Scoops

This architectural element is thought to catch a higher pressure air from roof top, carrying it below. This allows warm air to escape again from a higher opening. The effectiveness of the scoop depends on the opening angle (with an angle higher than 30° it starts to be ineffective). They can also be placed in the landscape outside of the building, with air being conducted via embedded ducts [24]–[30].

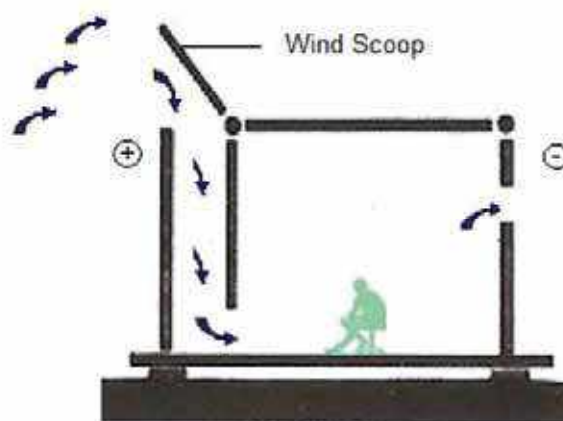


Figure 17: Wind scoop [24]





Figure 18: Wind cowls able to move with the wind changing direction in a beer brewing of Kent (England) [25]



Figure 19: Wind cowls enhancing NV in Nottingham Jubilee Campus (England) [25]

### 2.1.7 Rotating wind cowl, turbine ventilators, exhaust cowls, roof vents, roof cowls

These elements are used to enhance wind-driven ventilation. In order to improve the interaction with the external wind, they can be installed on the roof [24]–[30].

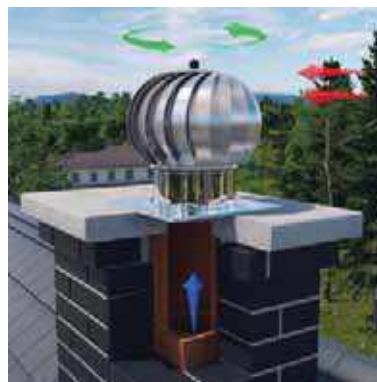


Figure 20: A roof chimney cowl, designed to increase and stabilize the draft of the chimney and the smoke ducts [31]

### 2.1.8 Ventilation openings in the façade

These elements are designed with the sole scope of being inlets and outlets for ventilation. In order to support a sufficient pressure drop, their size needs to be adequately designed. They can also be coupled with local suppliers or extractors [24]–[30].

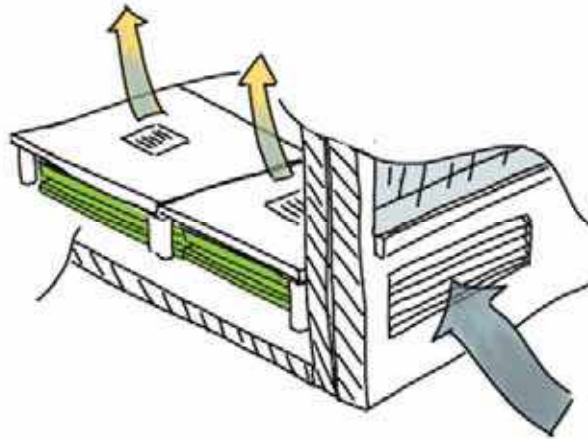


Figure 21: Ventilation openings in the façade [24]



Figure 22: Harm A. Weber Academic Center at Judson University in Elgin (Illinois, USA) – ventilation exhaust device on the roof [25]

### 2.1.9 Embedded ducts, ventilation chambers

These elements are defined as spaces within buildings, with the primary scope of collecting, transporting and distributing ventilation air [24]–[30].

## 2.2 Buoyancy driven natural ventilation

This technique of NV is driven by temperature gradient, which produces an upward airflow due to thermal buoyancy (Figure 23) [24]–[26], [28]–[30].

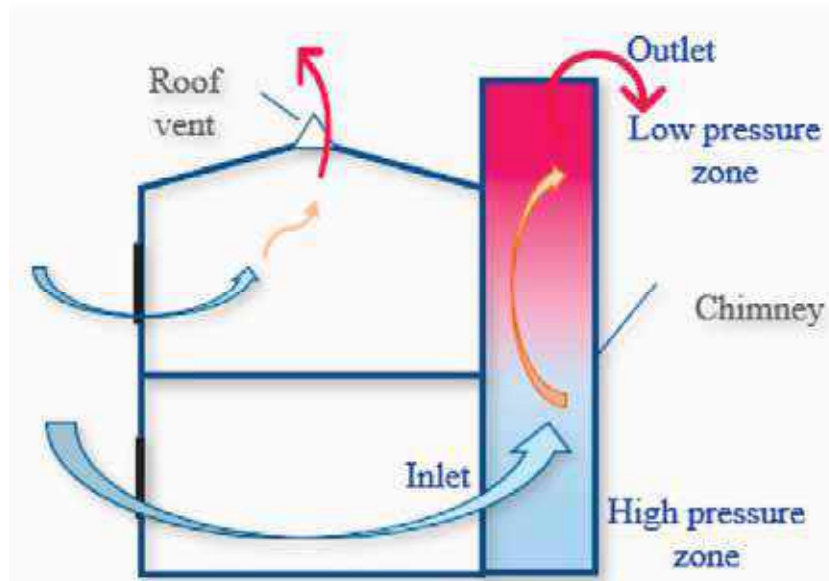


Figure 23: Stack ventilation [26]

### 2.2.1 Stack ventilation

With stack ventilation technique, cold air enters from lower openings in the envelope. Being heated inside the building, and thus becoming less dense, it leaves the building from openings high up in the envelope. With this technique, the heat removed from indoor environments is proportional to height difference between inlets and outlets [24]–[26], [28]–[30].

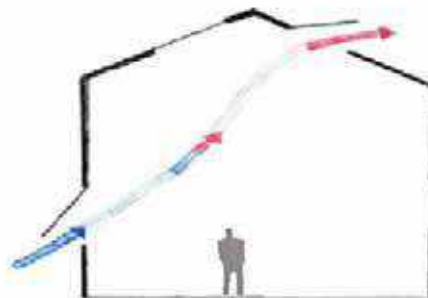


Figure 24: Mechanism of buoyancy driven natural ventilation [24]



Figure 25: Openings on opposite sides and at different heights of a space, allowing cross and stack ventilation [32]

### 2.2.2 Double skin façade (Vent-skin walls)

An additional second glazed envelope is added on the outside, creating a remarkable gradient of temperature, forcing the air to migrate upwards, being released by vents at the top. Automated vents in the inner skin allow indoor air to migrate from inside to the façade. Greenhouse effect can be used to pre-heat air during winter, but may constitute a drawback during summer. This design element can also be exploited for more advanced energy performance and daylight use [24]–[26], [28]–[30].

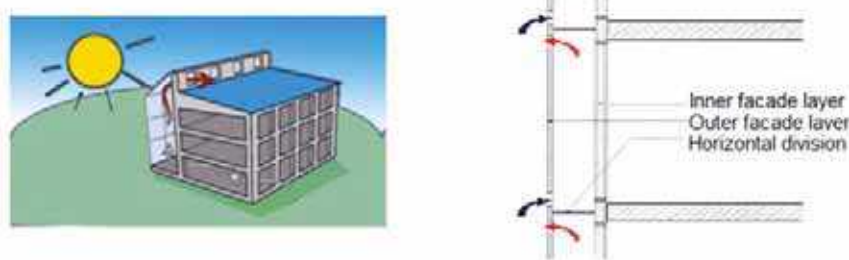


Figure 26: Mechanism of buoyancy driven natural ventilation in a double skin façade [24]



Figure 27: GSW building in Berlin (Germany) – cross ventilation is facilitated by the double glass façade providing a stack [25]

### 2.2.3 Trombe wall

Trombe wall is similar to a double-skin façade, but heat is also absorbed by the black-painted exterior surface of the more internal massive wall [33].

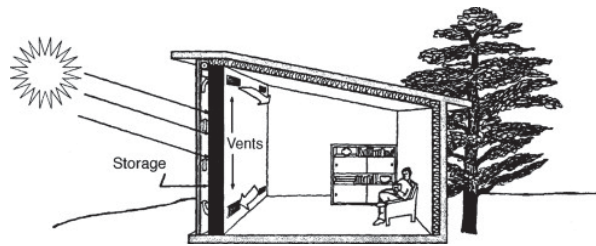


Figure 28: Trombe wall [33]



Figure 29: Trombe wall in Vivienda Trombe (Odeillo, France) [34]

### 2.2.4 Solar (thermal) chimney / Roof solar chimney

Chimneys are used to enhance the stack ventilation effect, used as a way out for air exhaust. The stack pressures can be increased by using incorporated glass elements (solar chimneys). Care needs to be taken in the design, e.g. chimney outlet needs to be located in a negative wind pressure zone (obtained by roof profile design). An extra fan can be incorporated for air extraction [24]–[26], [28]–[30].

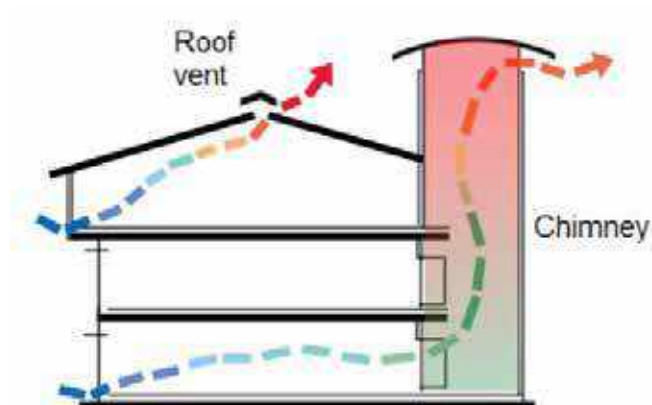


Figure 30: Chimney for NV [24]





Figure 31: McEwen Graduate Study & Research Building in York University (Toronto, Ontario, Canada) – a solar chimney for facilitating NV [35]

### 2.2.5 Solar façades (e.g. unglazed transpired solar façade and glazed transpired solar façade)

Solar façades are active façades designed in order to interact with solar radiation, exploiting it for heating, lighting or ventilation. Opaque façades absorb and reflect the incident solar radiation, without being able to directly transfer it inside the building. The scheme of a transpired solar collector is reported in Figure 32 [36].

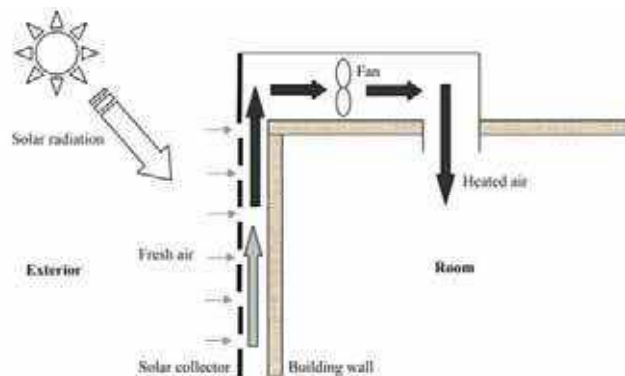


Figure 32: A scheme of a building integrated solar thermal system, such as the unglazed transpired solar collector [36]

### 2.2.6 Atrium

It is a variant of the chimney principles. In fact, air can be drawn out from both building sides to a central point for extraction. Also in this case, particular care needs to be taken with the positioning of outlet vents. This design element can also be used for more advanced daylight exploitation [24]–[26], [28]–[30].

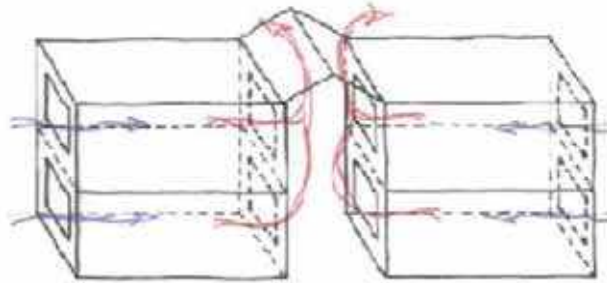


Figure 33: A NV strategy obtained by means of an internal atrium [24]

## 2.3 Main ways to exploit natural ventilation

NV can be used for different purposes, concerning the regulation of indoor environmental conditions. Main ways to exploit NV are listed here below.

### 2.3.1 Air-change

One first and intuitive purpose of NV is air-change. Thus, NV can be exploited for enhancing the Indoor Air Quality (IAQ) conditions, with CO<sub>2</sub>, pollutants and pathogens removal. The effectiveness of removal depends on NV efficiency and, of course, on outdoor conditions [37], [38].

### 2.3.2 Thermal regulation

Thermal regulation is the process of varying internal thermal conditions by means heat removal (cooling). This process depends on external environmental conditions, and is therefore dependent on the climate area and the season. As previously introduced, it was observed that the use of NV enlarges the temperature range of satisfaction inside building, thus allowing to develop adaptive model [18], [37], [39].

### 2.3.3 Night cooling

It is a particular way of thermal regulation, which consists in using NV (e.g., opening windows) during colder hours of the day (during night) for cooling the indoor environment. This technique can be coupled with the use of massive materials for improving thermal inertia of buildings and shifting the indoor heating later during daytime. Home automation systems (i.e., automated windows opening, automated shadings) can also be exploited for properly regulating indoor conditions depending on daytime and/or outdoor conditions [40]–[43].

## 2.4 Standards and guidelines for NV

- Theory and measurement of NV, application to design, strength and weaknesses of techniques of NV, mathematical modeling and computational fluid dynamics (CFD): D. Etheridge, *Natural ventilation of buildings: theory, measurement and design*. John Wiley & Sons. [28]
- Potential, appropriate use dimensioning, barriers' overcome of NV: S. Alvarez, E. Dascalaki, G. Guarracino, E. Maldonado, S. Sciuto, and L. Vandaele, *Natural ventilation in buildings. A design handbook*. James & James, 1998. [29]
- Reference book for designing low carbon/low energy buildings using NV, with example case studies: U. Passe and F. Battaglia, *Designing spaces for natural ventilation - An architect's guide*. Routledge. [25]
- Guideline on hybrid and passive cooling techniques for building (Italian language): M. Grosso, *Il raffrescamento passivo degli edifici in zone a clima temperato, Second*. Maggioli Editore. [30]
- Environmental design guideline containing NV recommendations applicable worldwide: CIBSE, 'TM40: Health and wellbeing in building services'. Chartered Institution of Building Services Engineers (CIBSE), 2019. [Online]. Available: <https://www.cibse.org/Knowledge/CIBSETM/TM40-2019-Health-Issues-and-Wellbeing-in-Building-Services#Exec%20summary> (<https://www.cibse.org/Knowledge/CIBSE-TM/TM40-2019-Health-Issues-and-Wellbeing-in-BuildingServices#Exec%20summary>) [44]

## 3. Mechanical ventilation principles in climate responsive energy positive buildings

**Mechanical ventilation (MV)** uses a powered induced airflow by means of a mechanical external source of power. For this reason, MV has the clear advantage to have the possibility to be perfectly regulated (airflow, volume, velocity, temperature), regardless of outdoor conditions. Thus, the performance of MV system is constant and perfectly predictable, and units of air treatment can be incorporated, remarkably improving IAQ conditions [45]–[47]. Main disadvantages are dealing with the running cost of MV systems, as they require electric energy to function. Moreover, mechanical systems for ventilation can lead to noise due to the functioning of plants. Lack of control (fixed air flow, not self-regulating) is also a disadvantage, as the air flow is fixed and not self-regulated [45]. Moreover, disadvantages dealing with the loss of contact with the outside environment might be associated with the use of MV systems instead of windows, even if this depends on the typology of view, area or landscape [48]–[54].

The disadvantage of the larger amount of consumed energy can be partially overcome by the use of heat recovery units, leading to passive houses applications of MV techniques [55]–[57]. An example of a heat recovery unit is reported in Figure 34.

A quick overview of the functioning of a heat recovery ventilation (HRV) plant, especially when coupled with a heat pump, is reported in following Subsection. Finally, a list of standards and guidelines for MV and heat recovery units is reported.

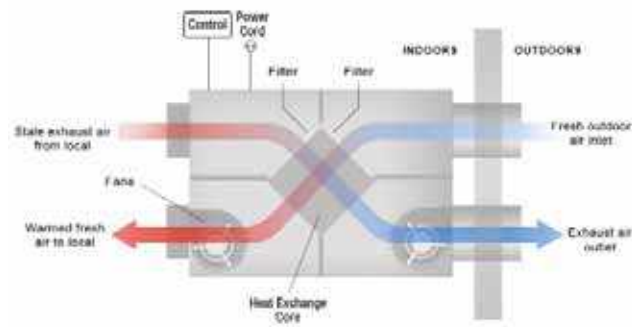


Figure 34: Scheme of a heat recovery unit [58]

### 3.1 Overview of Heat Recovery Ventilation (HRV) functioning

A HRV system is aimed at the exploitation of expelled exhausts to pre-heat or pre-cool the inlet air before it enters the room or air treatment units. It is normally composed of channels for exhaust and fresh air, a core unit and blower fans. It can generally improve the building energy efficiency by recovering between 60 and 95 % of heat in exhaust air. Several heat exchangers technologies are available for HRV, differentiating for the constructive point of view, as well as the air-flow inside them (parallel or counter-flow) [59]. Some examples of typical heat exchangers are [59]–[62]:

- **Fixed plate heat exchangers**, the most commonly used, with streams of cold and hot air passing through adjacent spaces between plates
- **Heat pipes**, transferring heat from between the two streams by means of a multi-phase process (evaporator-condenser)
- **Rotary thermal wheels**, mechanical exchangers with a porous metallic wheel alternatively in contact with cold or hot stream
- **Run-around**, hybrid systems using a mix of previous technologies to deliver heat between two distant air streams.

As heat pumps can be particularly efficiency and need electrical energy instead of fossil fuel to work, they are particularly interesting to be used in HVAC plants, when related with climate responsive energy positive buildings. In fact, they could cover most of global heating needs, remarkably reducing the CO<sub>2</sub> emissions [63]–[65]. Moreover, they can be inverted acting both for heating and cooling the environment. Performance of heat pumps is normally measured using the Coefficient of Performance (COP), defined as the heat transferred from low temperature to high temperature source divided by the work required [66]. A brief summary of heat pumps types of working technologies is here provided [67]–[69]:

- **Air source**, using outside air as heat source, being relatively easy to install, but being more performant in mild weathers than in cold ones; modern air source heat pumps are more performant, allowing to achieve COPs comparable to ones of ground source heat pumps
- **Ground source (geothermal)**, drawing heat from soil or groundwater, which (at a certain depth) maintains a relatively constant temperature for all the year (Figure 36)
- **Water source**, taking heat from a water source, which needs to be large enough not to freeze and not to affect wildlife
- **Exhaust air**, transferring heat from exhausts of a MV system to intake air or a water circuit
- **Solar assisted**, with a solar panel used as low-temperature heat source feeding the evaporator
- **Absorption**, which uses thermal energy (natural gas, steam solar-heated water or air, geothermal-heated water, ...); this system is more complex than compression heat pumps, requiring larger units
- **Hybrid**, drawing heat from different sources depending on temperature present outside.

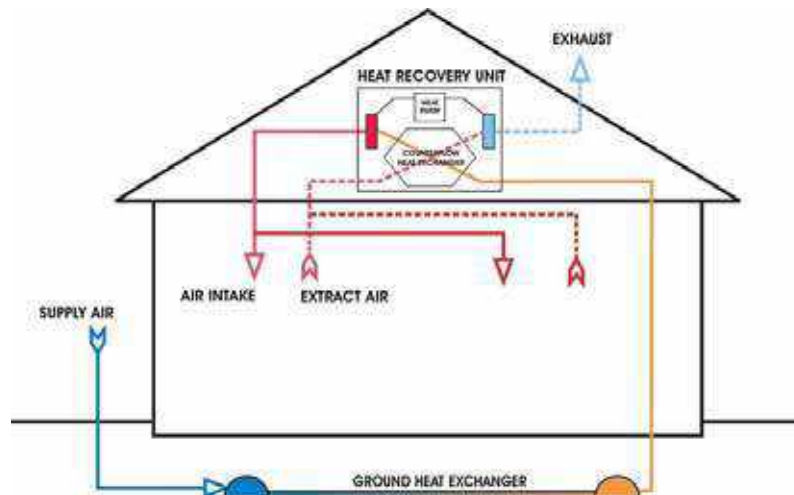


Figure 35: Scheme of a HRV system [70]

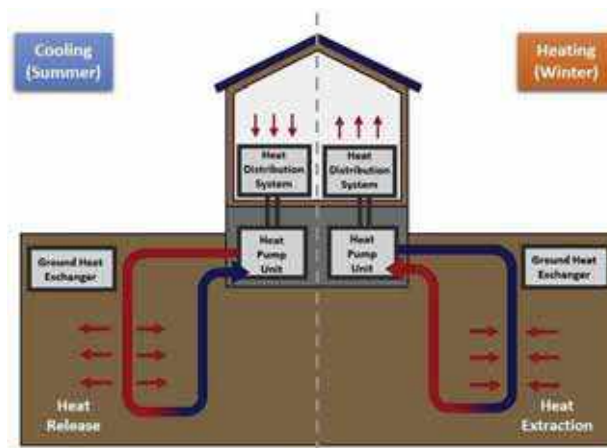


Figure 36: Scheme of a ground source heat pump in cooling and heating mode [71]

### 3.2 Standards and guidelines for MV

- Basic principles and data used in the HVAC industry: ASHRAE, ASHRAE Handbook - Fundamentals. American Society of Heating, Refrigerating and Air-Conditioning Engineers (ASHRAE), 2021. [72]
- Standard for plants' classification, minimal requirements of plants and indoor environments: UNI 10339 - Air-conditioning systems for thermal comfort in buildings - General, classification and requirements - Offer, order and supply specifications. [46]
- Handbooks and manuals on domestic ventilation:  
HRAI, *Residential Mechanical Ventilation - National (SAR-R4)*. The Heating, Refrigeration and Air Conditioning Institute of Canada (HRAI), 2010. Available: <https://www.hrai.ca/technical-manual/residential-mechanical-ventilation---national--sar-r4-> [73]  
R. Edwards, *Handbook of Domestic Ventilation*. London: Taylor & Francis, 2005. Available: <https://doi.org/10.4324/9780080454580> [74]  
P. H. Raymer, *Residential Ventilation Handbook, 2nd ed. Home Ventilation Management*, 2017. [75]
- Overview on main building heat recovery technologies: A. Mardiana-Idayu and S. B. Riffat, 'Review on heat recovery technologies for building applications', *Renewable and Sustainable Energy Reviews*, vol. 16, no. 2, pp. 1241–1255, Feb. 2012, doi: 10.1016/j.rser.2011.09.026. [59]



- Guidelines on heat pumps:  
ASHRAE, 'Applied Heat Pump and Heat Recovery System', ASHRAE.  
<https://www.ashrae.org/advertising/handbook-advertising/systems/applied-heat-pump-and-heat-recovery-systems> [76]  
'Domestic Heat Pumps - A best Practice Guide'. Available: <https://mcscertified.com/wp-content/uploads/2020/07/Heat-Pump-Guide.pdf> [69]

#### 4. Hybrid ventilation principles in climate responsive energy positive buildings

As introduced in Section 2, NV has the advantages of reducing the carbon footprint of buildings, while also improving some comfort elements, such as ones dealing with users' willingness of control and access to the outside/nature. On the other hand, MV (Section 3) is a "safer" technique, as it permits to have more controllable IAQ and thermo-hygrometric conditions, also allowing for filtering pollutants and better removing pathogens. A compromise between the two methodologies is **hybrid ventilation (HV)**, or **mixed-mode ventilation (MMV)** [77]–[82]. In fact, the primary purpose of HV can be defined as "to provide acceptable indoor environment and thermal comfort [...] using different features of these systems at different times of the day or season of the year". Therefore "Hybrid ventilation buildings, or mixed mode buildings, represent the buildings that have the capability of running the natural ventilation and mechanical ventilation concurrently or switching between these two modes during the building operation" [83]. In this way, the greatest advantages of ambient conditions can be exploited at any time. Moreover, an automatic intelligent control can allow to switch from one mode to the other when needed [84], [85]. The main principles of HV are reported in Figure 37.

Thus, the alternation of MV and NV could save up to 75 % of the energy use [80], while guaranteeing proper IAQ conditions. For this reason, this solution is particularly interesting for climate responsive and energy positive buildings.

Further information on HV technique can be found, for instance, on:

- *Principles of Hybrid Ventilation. Aalborg (Denmark): Aalborg University, Hybrid Ventilation Centre. Available: [https://iea-ebc.org/Data/publications/EBC\\_Annex\\_35\\_Principles\\_of\\_H\\_V.pdf](https://iea-ebc.org/Data/publications/EBC_Annex_35_Principles_of_H_V.pdf) [84]*
- *Annex 35 - Hybrid Ventilation in New and Retrofitted Office Buildings. Hybrid Ventilation in New and Retrofitted Office Buildings. Available: [https://www.iea-ebc.org/Data/publications/EBC\\_Annex\\_35\\_tsr.pdf](https://www.iea-ebc.org/Data/publications/EBC_Annex_35_tsr.pdf) [81]*

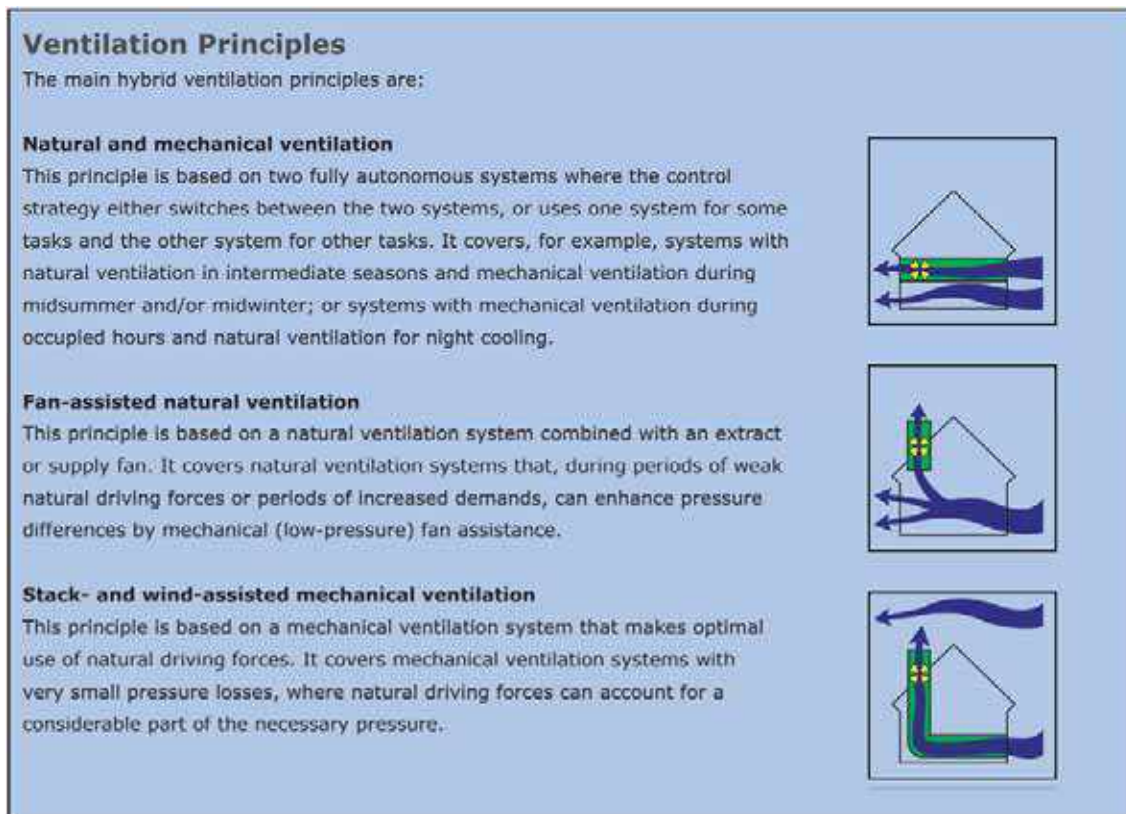


Figure 37: Examples of HV principles [84]

## 5. Natural, mechanical and hybrid ventilation with a double perspective, focusing on both energy consumption and indoor well-being

Given these premises, it is clear that the concept of ventilation is fundamental, when dealing with both climate responsive and nPEBs. In fact, NV can remarkably reduce the carbon footprint, which is a clear requisite of both these forms of energy-efficient architecture [86], [87]. Climate responsive principles can be observed in traditional buildings such as vernacular architecture in Nepal, which have been using natural ventilation for years, in order to adapt to climate conditions and improve comfort of occupants [88]. Nevertheless, as previously stated, MV allows for a better regulation of IAQ and thermal conditions. In fact, building design cannot overlook indoor comfort. Good environmental quality is also fundamental for work and performance, as well as for energy consumption. In fact, energy implications may derive from actions taken from occupants to improve their uncomfortable conditions [89], [90]. As Chenari et al. [91] points out, it is not possible to choose one ventilation solution relying on energy savings criteria, if indoor comfort cannot be met. In fact, ventilation is fundamental to provide a health and comfortable indoor condition, avoiding illnesses and complaints present in 40 % of cases [92]. Also, COVID-19 pandemic highlighted the importance of ventilation in buildings, with controversial opinions about the preferred use of MV [10], [93]–[97]. In fact, NV re-gained interest because of its utility to manage infection control in buildings [37], [98] and because of the preference of nature-connected environments by people [50]–[54]. For instance, window presence and window opening were found to possibly positively cross-influence the mental well-being of occupants during COVID-19 lockdown in London, as positive perceived soundscapes were found associated with psychological well-being, as well as with natural sounds and view of vegetation [48], [49]. On one hand, in the field of building resilience to climate change, within the next decade indoor spaces might terminate to fulfil adaptive comfort model [99]. Moreover, global warming will probably provoke an higher number overheating hours in warm areas, but the shifting of climate conditions might cause a higher use of NV in cold or mild climates [79]. On the other hand, even though open windows cannot be a proper solution when poor outdoor air

quality, too warm conditions or too low wind are present, other future Indoor Environmental Quality (IEQ) issues might be created by totally avoiding NV. This solution would also create a situation relying on a totally dependence on HVAC systems, with large emissions and energy demand. For this reason, new regulatory criteria on overall IEQ in buildings are necessary, not to worsen the global climate emergency and future health problems [10].

For all these reasons, the careful study of ventilation with both an energy saving and IEQ perspective is fundamental. Both the two criteria need to be considered when designing climate responsive and net-positive energy buildings. In this section, a systematic literature review on studies analyzing an indoor comfort and/or well-being comparison between NV and MV is presented. The aim is to offer an overview aiming as a guideline for choice of best solution of NV, MV or HV in the design of nPEB or climate responsive buildings.

### 5.1. Methodology

A process of systematic review was used [100] on the Web of Science database [101]. A search using AND/OR Boolean operators [102] (Figure 38) was performed in order to identify all the studies concerning a comparison of NV and MV in terms of indoor comfort and well-being. A total number of 94 papers was found. A first screening process was applied considering only English-written studies and limiting the research areas to the following: 1. *Construction Building Technology*; 2. *Engineering Civil*; 3. *Engineering Environmental*; 4. *Green Sustainable Science Technology*; 5. *Environmental Sciences*; 6. *Public Environmental Occupational Health*; 7. *Environmental Studies*; 8. *Architecture*; 9. *Thermodynamics*; 10. *Engineering Mechanical*; 11. *Infectious Diseases*; 12. *Regional Urban Planning*; 13. *Urban Studies*. All types of documents (articles, proceedings papers, review articles and book chapters) were considered, obtaining a total number of 80 papers. A second screening process consisted in titles and abstracts reading, with the rejection of all the papers which topic was not in compliance with a comparison of natural and mechanical ventilation related with occupants' comfort and/or well-being. This screening allowed to obtain 69 papers for full reading. After the reading process, five additional papers were discarded, with a final number of 63 studies considered. Figure 39 reports the details about the screening process, and the number of studies obtained after each phase.

Resulting studies were categorized according to the comfort field considered (thermo-hygrometric, visual, IAQ, acoustic and multi-domain approach), as well as the type of ventilation recommended ("NV", "MV", "HV or both HV and NV", "no clear preference between MV and NV/HV"). Papers are presented here below grouped according to this last categorization. The type of paper (journal paper, journal review, conference proceedings), the type of indoor environment (residential, educational, working, ...) and the climate or geographical area considered were also highlighted. When specified, the type of NV ("thermal regulation", "air-change" or "night cooling") was also highlighted.

Finally, statistical data about papers are presented, highlighting the number of studies per publication year, geographical area, research field and other types of categorization.

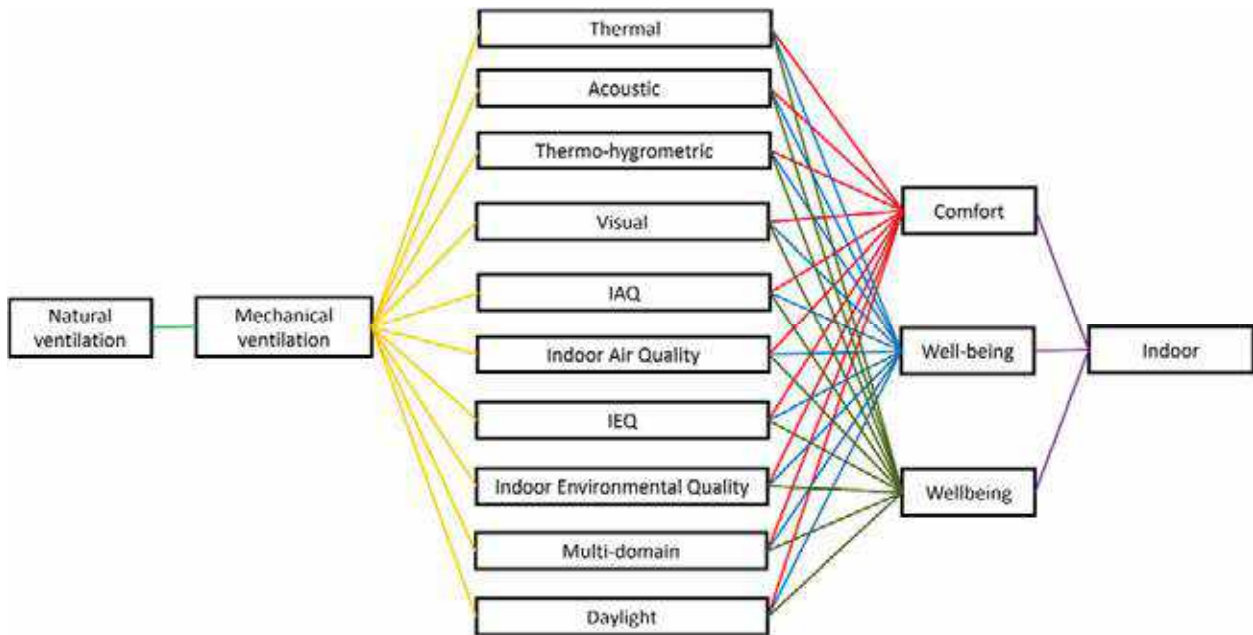


Figure 38: Boolean research string used for a first search of papers on the Web of Science database. Linking lines represent "AND" operator, while "OR" operator was used for keywords on the same column in the scheme

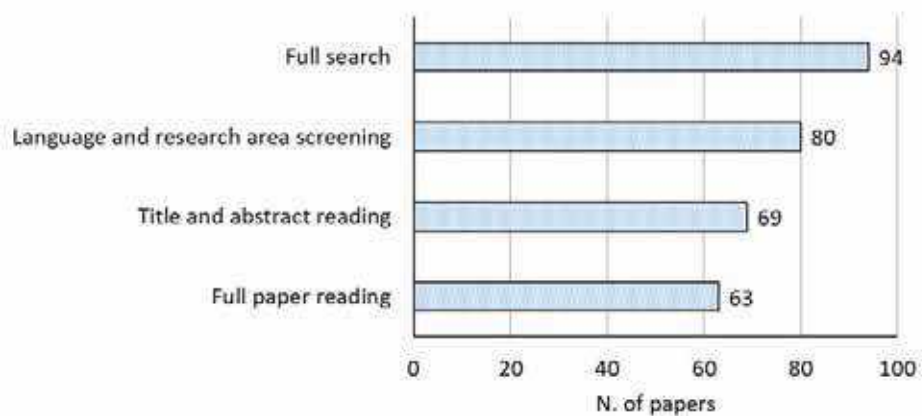


Figure 39: Details about the screening process applied and number of results after each phase

## 5.2. Results

### 5.2.1. Studies suggesting the use of NV

A Slovenian study of 2007 [103] analyzed comfort in three working buildings (two with MV and one with NV). It used surveys performed during normal activities of work, in the cold season. Thermal measurements of the environments were taken simultaneously. Health problems and health status of occupants were also surveyed. Deviations between predicted and subjective evaluations were noticed, with possible influence of psychological factors. Moreover, in mechanically ventilated buildings, a higher dissatisfaction with thermal and air quality environment was present. On the other hand, neutral condition was expressed by a higher percentage of occupants in the naturally ventilated building than in the two other buildings.

In a review by Omer (2008) [104], a description of several low-energy buildings design solutions was performed, also highlighting implications of dense urban building nature on consumption of energy and climate change. It was highlighted how maintaining thermal comfort in buildings by means of low-energy and passive techniques is one effective way to save energy, and therefore maximum share of natural energy should be used. For these reasons, new technologies like louvers for distribution of light, insulation, MV operations and simple passive cooling can help in fulfilling this target, with a combination of well-known technologies like shading, glazing, NV and insulation and other advanced solutions such as dynamic insulation, roof pond and evaporative water jacket. Moreover, the need of mechanical cooling and heating could be reduced designing buildings taking into account the climate of the area (climatic design). Using the proper building and urban design, the deterioration of environmental quality after urban densification could be minimized. For instance, thermal comfort could be maintained in arid regions by means of wind towers. Moreover, CO<sub>2</sub> emissions are also increased by poor design or control of passive ventilation systems (i.e., too high inflow), besides than too strong use of MV. Discomfort and draught are caused by too high outdoor air, while poor IAQ is caused by little inflow. For these reasons, proper design of NV solutions (single-sided ventilation, cross-flow ventilation, mixed-flow ventilation or other solutions like solar-induced ventilation) need to take into account the following buildings' factors and characteristics: ceiling height, space exposed thermal mass and building materials (e.g. for night cooling), depth of space in relation with ventilation openings, heat gain, building location in relation with sources of pollution (such as traffic noise and air pollution). Also, geographic location, exposure to sun, wind and rain (including effect of buildings themselves on them), building height and form, need to be taken into account. In this framework, CFD can help with problems in the design of air movement in rooms and airflow control.

In 2008, Stavrakakis et al. [105] performed a test-chamber and numerical (CFD) examination of natural cross-ventilation with non-symmetrical openings. In a test-chamber in rural Greece, velocity and temperature measurements were recorded during noon and afternoon in the hot season, while a weather station provided data about external weather conditions. Thermal comfort (thermal regulation perspective) was studied by means of both PMV and adaptive models. The study started from the idea that NV can help in saving energy, but needs to be properly designed based on airflow detailed understandings (pressure differences due to wind and buoyancy). It was highlighted that experimental measurements agreed quite well with all turbulence models, pointing out that well-mixed conditions can be provided by openings' locations which are not symmetrical. This can minimize local air draughts and temperature differences, avoiding unsatisfactory thermal environment even close to obstacles like pieces of furniture.

A CFD modeling to investigate the comfort performance of stack effect (buoyancy) and two driving forces-wind ventilation in a double-skin-façade university building (Figure 40) in Mediterranean climate (Eugene, Oregon), was studied by Azarbayjani (2013) [106]. The study highlighted that heat can be effectively drawn out by means of cool night air through top openings and that acceptable thermal comfort conditions can be provided by NV in the building with double-skin-façade. Moreover, air extraction can be obtained using the convective forces in the cavity, but air movement within the room should be promoted in order to release heat in excess. Finally, the climate analysis showed that, in summer or shoulder seasons, NV was made possible by orientation of building, which considered the prevailing winds. Therefore, comfort was studied with a thermo-hygrometric perspective and NV for night cooling and thermal regulation was considered.





Figure 40: Double-skin façade of the university building considered by Azarbayjani study [106]

A review on existing studies supporting NV efficiency and architectural designs and solutions to maximize the efficacy of NV in buildings in tropical (hot and humid) climates was performed by Aflaki et al. (2015) [107]. The paper points out how high humidity and temperature might provoke occupants to use MV in tropical climates. Nevertheless, the authors state that, with passive techniques such as NV, smaller operational cost and better IAQ and thermal comfort have been shown by many researches. Review results showed that future constructions should exploit design strategies such as window-to-wall ratio, orientation of buildings, position and size of openings, façade elements, balconies' form and ventilation shafts in order to optimize NV. Moreover, further studies on louvered windows' shape (for night ventilation), vernacular elements and apertures' forms could be needed.

The importance of design elements such as façades, orientation and structure in non-residential buildings in warm climates was pointed out by Annan & Nehme in 2016 [108], assessing the effect of cross and single-sided ventilation by windows and skylights openings that can be used for cooling the building with a thermal regulation perspective.

Da Graça & Linden (2016) [79] developed a list of 10 open questions about design of NV in non-domestic environments, from building, neighborhood and urban point of view. The authors linked the answers to the proposed questions with current literature, in order to identify the scientific gaps and provide designers with proper suggestions. It was pointed out how NV benefits of the preference of most people, who are also characterized by a higher thermal tolerance when rooms are naturally ventilated and openings can be controlled by users. Nevertheless, NV is still rare in non-domestic and modern buildings, but its usage could make the energy consumption decrease. Recent design solutions with the massive use large glazed walls have driven to the misunderstanding that NV and natural light compete. Nevertheless, the two systems can benefit from similar constructive techniques (i.e., high windows, high floor to ceiling height, operable skylights, both have a small penetration depth when windows are located on the same side, ...). Moreover, direct sunlight on large glazed façades can lead to both overheating and glare. Thus, both systems could benefit of a return to smaller window to wall ratios, climate adaptive building shells and use of external shadings. NV can possibly be applied with an outside temperature range from 10 °C to 25 °C. For this reason, climate change will rise the number of hours of overheating in non-commercial buildings, but, in cold and mild climates, will also lead to an expansion of hours of open windows. Innovative approaches (e.g., night cooling with thermal massive or phase-change materials equipped buildings, controls avoiding overheating during the warmest hours) may be useful for a NV use expansion. Moreover, coupling with external shadings, responsive glazing and ceiling fans to move air could be necessary. Modern mobility solutions (i.e., electric

cars and bikes) will improve the urban environment in terms of particles and noise pollution. Thus, NV will further benefit.

Reasons of unpopularity of NV (with respect to air-conditioning or HV) in Green-rated offices of New Zealand were investigated by Rasheed et al. (2017) [109] by means of: (1) revision of criteria of thermal comfort in NZ Green Star [110], [111] rating tool; (2) online questionnaires of workers' perception of thermal comfort in the city of Auckland (most populated and with high number of modern office buildings; oceanic subtropical climate); (3) building experts' interviews. The following conclusions were listed: (1) NV was not encouraged by NZ Green Star IEQ thermal comfort criteria. (2) No preference of NV over MV and HV was observed among workers. (3) Among thermal comfort factors, the highest impact on workers' performance was noticed to be by temperature control and temperature extremity. (4) NV could be promoted by a better support to adaptive criteria from NZ Green Star IEQ thermal comfort criteria. This would possibly imply a preference change of accustomed workers. In this way, thermally comfortable Green offices would be achievable. (5) NV negative implications on productivity are still under debate. Therefore, energy inefficient buildings should not be built on those basis. (6) Other IEQ aspects connected to NV (i.e., lighting and noise) should be deepened by further studies.

In 2019, Mukhtar et al. [112] performed a review on strategies of passive design and building optimization potential in underground buildings. It was stated that incorporating passive systems in underground buildings is fundamental to mitigate the carbon impact. In this sense, IEQ level could be improved by including passive design strategies and optimization approach in building performance simulations. Moreover, the energy consumption could be decreased by adopting natural and soil ventilation (Figure 41: Earth to air heat exchanger (EATHE)). Nevertheless, factors like geological features, physiological and psychological issues, construction typologies and ventilation system should be taken into account for the proper design of underground buildings. In this framework, thermal comfort improvement and reduction of the energy consumption could be fostered by passive design technologies specifically associated with underground buildings.

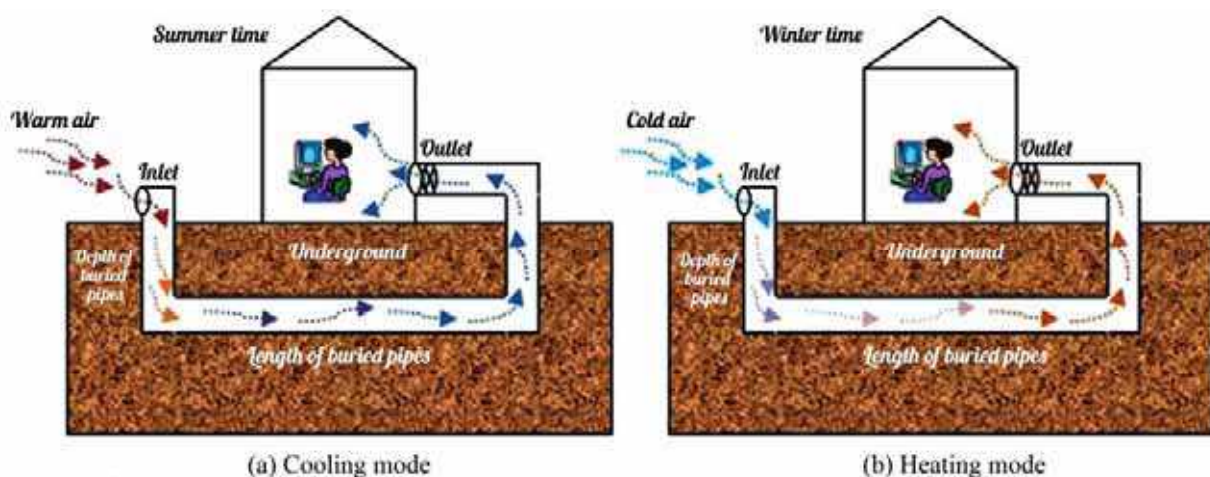


Figure 41: Earth to air heat exchanger (EATHE), reproduced from [112], [113]

Maas et al. (2019) [114] studied a 60 seats capacity seminar room of University of Luxembourg (a Seventies building with no major retrofitting). The MV system was switched on and off for periods of some weeks each. After each period, measurements of final energy consumption and of indoor climate (by both physical measurements and questionnaires) were performed. The building was not air-tight and manually operable windows were present. The research led to the following conclusions: (1) When the system was "on", light

measurable benefits in the CO<sub>2</sub> concentrations were present, and it was not perceived by the occupants. (2) Primary energy consumption of the building was clearly higher when the system was “on”, due to fans' electric demand. (3) There was no relationship between the climate perceived and the perceived percentage of dissatisfied. (4) Advantages can be achieved in older buildings' seminar rooms, by shutting down or semi-automatic user-controlled modus by low-cost retrofitting.

A literature study on the influence of openings of façades and geometry of balconies on perception of occupants and NV performance, comparing design characteristics and geometries, was performed by Izadyar et al. in 2020 [115]. The paper started from the idea that NV could be used on its full potential, in particular in medium- and high- rise buildings. In this framework, airflow could be guided by balconies into the indoor environment, reducing the need of MV and improving the comfort conditions. Not enough studies were performed on the exploitation of balconies for NV. More studies, comprising both experiments (like Post-occupancy Evaluation) and simulations, should be made. Most of the studies present in the literature, have been performed in cooling dominant warm/hot climates. Nevertheless, climate change should drive the research expand also to heating-dominant areas. Design process impact of passive elements was not sufficiently explored, with indoor comfort and health factors being mainly considered in previous studies. More post-occupancy evaluation studies should be made, in order to link NV design and perception of occupants: this would allow to better investigate the façade openings' design effect on occupants.

In 2020, two other studies from Izadyar et al. [116], [117] analysed the performance of single-sided NV and related thermal comfort of a living room depending on depth (fixed length over depth size, L/D) and opening scale of a balcony, in a high-rise residential building in Brisbane (Australia). CFD simulations were performed after measurements' validation, assessing the mean Indoor Air Velocity (IAV), the Indoor Air Distribution (IAD), and the PMV. Nine depth scenarios and five openings were considered. The following aspects were highlighted in [116]: (1) NV could decrease energy consumption and GHG emissions with respect to MV. (2) Depth and openings of balconies have an impact on IAD and IAV and indoor temperature. (3) Shallowest balconies give a weak IAD, and small openings give acceptable IAV indoor. (4) Further research to study the influence of geometry on indoor comfort and indoor temperature and air velocity distribution are necessary. Moreover, these additional points were pointed out in [117]: (1) Balconies could enhance NV, reducing dependence on MV in climates with cooling dominance. (2) The opening size and the depth scale influence IAD, IAV and thermal comfort. In fact, a small opening could reduce exterior air acting like a nozzle in transferring the recirculation farther in the room. Larger openings were seen to create extended cold areas close to the opening. (3) Smaller depth (less than 2 m) gave not stable and not uniform IAD, with deeper balconies being more performant on the point of view of thermal condition and IAV. In terms of thermal conditions, it was noticed that the best solution had a L/D of 35 % and opening size of 1.1 m. (4) Orientation of buildings influence the balcony's depth impact on mean IAV. Further studies are necessary to assess the proper depth with other orientations.

Yadeta et al. (2022) [118] performed a field survey (questionnaires, indoor and outdoor air temperature, humidity and air speed) in 104 naturally ventilated residential buildings in Jimma (South-West Ethiopia, warm-temperate climate), during the dry season (from 1<sup>st</sup> of February to 31<sup>st</sup> of May 2020). A neutral temperature of 20.4 °C and a wide comfort range (14.6 - 26.3 °C) were found. This suggested that, in developing countries like Ethiopia, thermal comfort can be achieved by NV, with occupants using natural adaptive means, allowing to save energy for MV, if compared with areas with narrower ranges. Moreover, it was highlighted how further studies on energy consumption from heating and cooling in the households would be necessary in these countries.

Mba et al. (2022) [119] investigated the NV effect of orientation of 60 primary schools buildings in the city of Enugu (Nigeria, hot-humid tropical climate). The paper firstly stated the fact that, in developing countries, educational buildings rely on NV in order to save energy. It was found out that the efficiency of ventilation depends on the orientation: inlet window planes perpendicular to the wind direction are recommended.

Moreover, inlet and outlet dimensions and positioning have an impact. Additionally, the authors stated that shading devices and corridors to promote the use of NV also during rainy and windy days should be used, and encouraged architectural solutions to couple wind and stack effect ventilation.

### 5.2.2. *Studies suggesting the use of MV*

A review by Braham (2000) [120] focused on independently published information on low-energy office buildings performance data about the ventilation and fabric energy storage strategies available, in the temperate maritime climate of the UK. The work started from the idea that not many studies about annual energy associated with NV and MV coupled with fabric thermal storage were published. The review concluded that, when including effective fabric energy storage with the integration of efficient heat recovery (using hollow-core slabs), low-energy MV systems can provide better comfort all over the year (with summer cooling included) and lower energy consumption than NV. Moreover, less maintenance is necessary. In temperate marine climates, it was shown that minimal supplementary demand and consumption of heating and cooling are needed.

A paper by Sultan (2007) [121] estimated the effects of outdoor PM (particulate matter) mortality and morbidity effects on the Singapore population under various buildings and conditions of ventilation and filtration. The study concluded that nationwide adoption of NV in residential buildings was associated with higher morbidity cases and mortality. Moreover, MV and filtration from current NV in schools was associated with less asthma cases. Additionally, better filtration in workplaces was associated with lower morbidity cases and mortality.

A study by Khaleghi et al. (2011) [122] provided a direct monitoring of IAQ (volatile organic compounds - VOCs and ultrafine particles, respirable-fibre concentrations), ventilation rates (air changes per hour) and acoustical conditions (times of reverberation and levels of noise) in study rooms located in selected "non-green" and "green" university campus buildings (Vancouver, Canada). Then, the two aspects of IAQ and acoustic comfort were considered, with an air-change point of view. The goal was to quantify these IEQ aspects, determining their relationship with design of building and windows' status and assessing the effects for systems of ventilation, especially in buildings considered as "green". The measurements were taken both in buildings with MV (mixed-flow and/or displacement) and NV. NV produced lower total sound-pressure and low-frequency noise, as well as lower fibre concentrations, but also lower rates of ventilation and higher ultrafine-particulates. Direct association between noise level and IAQ was observed with MV. It was concluded that a generally better IAQ can be provided by MV, even if poorly designed systems can produce noise issues. Higher noise levels was produced with higher ventilation rate by windows' openings. Finally, the use of MV with careful attention to noise, was suggested for optimum building design.

Guo et al. (2018) [123] used reduced-scale model, full-scale numerical simulation and similarity analysis to evaluate performance of buoyancy-driven ventilation in a large space building (ocean park) with a large glass ceiling. An investigation of conditions of thermal comfort was performed numerically. It was concluded that in a similar type of building (with a large glass ceiling), buoyancy-driven ventilation alone is not enough to ensure thermal comfort conditions, when high ambient temperature is present. Therefore, MV is needed in similar environments.

Measurements of indoor and outdoor particle number, as well as concentration of CO<sub>2</sub>, were performed by Stabile et al. (2019) [124] in a school of Cassino (Central Italy). Pre-retrofit (different procedures of manual airing) and post-retrofit (CO<sub>2</sub>-based controlled ventilation, with a set-point of 1000 ppm) solutions were considered. It was highlighted that, for highly crowded buildings like schools, MV is necessary. Moreover, evaluating the air quality just by means of CO<sub>2</sub> concentration constitutes an over-simplified approach, since other pollutants are present. The study concluded that: (1) With longer airing period, significantly lower CO<sub>2</sub>



was present, but more sub-micron particles infiltrated from outside and no reduction of PM<sub>10</sub> generated indoor were observed. (2) MV produced improvements on all the measured pollutants and on energy savings. The reduction of PM<sub>10</sub> particles was caused by the higher rates of air exchange, giving better dilution effects. Moreover, the lower energy consumption was due to the presence of a heat recovery unit after retrofit. (3) Further analysis dealing with other pollutants (e.g., NOx), as well as thermal comfort and performance of children are necessary.

Zender-Świercz (2020) [125] performed an analysis of indoor air parameters of a Polish (moderate climate zone, low temperatures in winter and high temperatures in summer) office equipped with a façade ventilation device. Measurements of indoor and outdoor temperature, indoor and outdoor humidity, indoor CO<sub>2</sub> concentration were performed. The monitoring lasted twenty-six weeks during the fall-winter-spring period. Three different periods with different unit settings for the supply/exhaust cycle (2 min, 4 min and 10 min) were analyzed. It was pointed out how, with thermal insulation and new sealed windows, buildings only exploiting NV can undergo to lack of infiltration and insufficient air exchange. Moreover, due to a lack of place and architectural requirements, MV cannot be always installed. Temperature was observed to be in the range of 20 - 22 °C despite the absence of a heater in the device. PMV calculations showed that building categories B or C (PN EN 7730 [126] categorization) were maintained. Local draught risks with long air supply/exhaust cycle, when users stand in the air stream axis, were also noticed. Exhaust heat recovery and electric heater were recommended to decrease the possibility of local discomfort. Finally, low RH values (27 - 43 %) suggested to recommend air humidification.

A numerical energy efficiency assessment and an IAQ assessment were performed by Mareş et al. (2021) [127] in a single-family thermally insulated house in Cluj (Romania). The house was also equipped with low-transmittance windows and an efficient boiler. Since the substitution of old wooden framed windows with double glazed PVC windows, even if giving better thermal performances, might create air sealing issues, an evaluation of a controlled MV remedial system mitigating IAQ problems was performed. The mitigation solution considered was a decentralized MV with heat recovery coupled with a sub-slab depressurization system to reduce the radon concentration. This system gave a reduction in the radon average concentration from 425 to 70 Bq/m<sup>3</sup>, also guaranteeing a CO<sub>2</sub> concentration around 760 ppm and thermal comfort (temperature around 21 °C). Compared to NV solution, this system gave an energy reduction of 86 %. It was therefore concluded that, when thermally retrofitting a building, there is the need to perform a balance between IAQ and energy consumption, allowing to find a remediation solution for poor IAQ.

Liao et al. (2021) [128] used an online questionnaire survey on the type of ventilation and the associated subjective sleep quality among 517 people in Danish dwellings, during winter 2020 (before COVID). The following information was asked: type of ventilation of bedroom, respondents' behavior on bedroom airing, information on bedroom environment, building location and surroundings, information on sleep disturbance by noise, stuffy air and thermal environment. Pittsburgh Sleep Quality Index (PSQI) was used to assess the sleep quality. An average reduced sleep quality was reported (median PSQI > 5). Noise, thermal discomfort and stuffy air were found to be related with less subjective quality of sleep. The presence of MV reduced the disturbance by "too cool" conditions and stuffy air while sleeping (Figure 42). The presence of carpets and the absence of MV seemed to cause sleep disturbance due to stuffy air. A more frequent opening of windows was detected among people who reported disturbed sleep by "too warm" or stuffy air conditions. On the other hand, no association between airing behaviors and PSQI was observed. Finally, it was specified that this study presented qualitative results and associations during the heating season: therefore, they need to be validated with field measurements and repeated during non-heating season to be generalized.



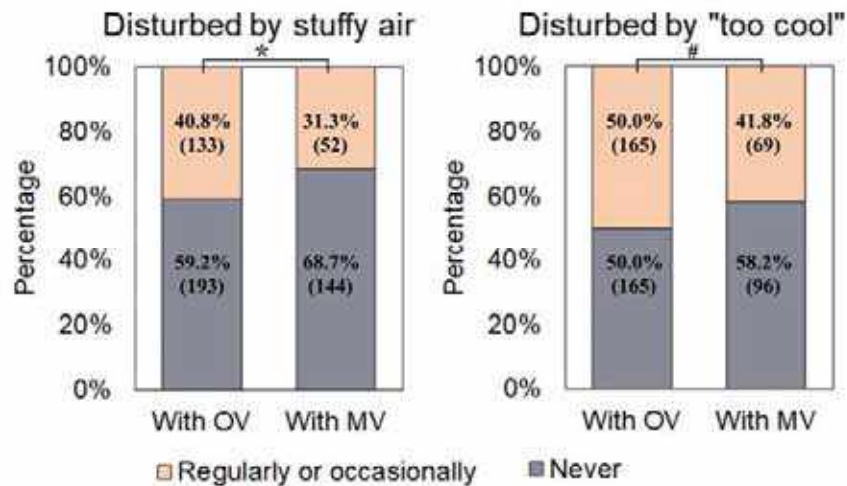


Figure 42: Percentage of people disturbed ("regularly or occasionally" and "never") by stuffy air or "too cool" conditions during sleep. Results for mechanical ventilation (MV) and other ventilation (OV) are differentiated. Reproduced from Liao et al. (2021) [128]

A review by Ding et al. (2022) [129] analyzed the ventilation strategies and IAQ conditions of classrooms, in order to study the capacity and further improvements in minimizing the presence of infectious aerosols. The following aspects were highlighted: (1) NV and mixing mechanical ventilation are mainly used in schools, but these systems are not fully effective in dealing with short-range and long-range airborne transmissions. (2) Current literature and standards lack of knowledge dealing with design and rates to ensure safety from airborne transmittable pathogens. There is still uncertainty about patterns of air distribution and rates of ventilation. There is still a main focus on perceived air quality, CO<sub>2</sub> concentration and energy savings on standards, and many schools even fail to meet the current air-change requirements. Therefore, there are several reports of problems dealing with comfort, IAQ, performance or health. (3) New ways of ventilation are needed in classrooms, moving the design from comfort- to health-based. Personalized ventilation can potentially protect from short-range generated aerosols, with a simultaneous IAQ improvement, compensating existing ventilation regimes. (4) Before applying these new methods in classrooms, there is the need of more studies, also considering the types and activities of occupants. (5) IAQ changes have the potential to influence the other IEQ factors, which interact together into giving occupants' comfort and health. This aspect needs to be considered when updating ventilation systems, with a holistic approach both ensuring health and IAQ in schools.

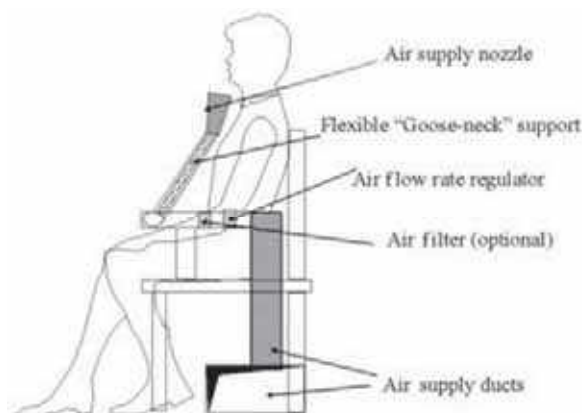


Figure 43: A chair-based system of personalized ventilation, reproduced from [129], [130].

### 5.2.3. Studies suggesting the use of HV or both NV and HV

The first paper recommending the exploitation of HV was written by Mathews et al. in 1994 [77]. The study validated and proposed a procedure to verify efficiency of load predictions of programs for thermal analysis to be used at the design stage to assess comfort regulating methods. The research involved 36 buildings in various climate conditions for 46 case studies. The article highlights how the study of NV, MV, passive performance and building's structural and evaporative cooling are necessary in the thermal and energy efficient design of buildings. Mechanical cooling techniques should be used only when these systems cannot provide with the desired thermal comfort. Moreover, by combining passive and mechanical cooling and various strategies of control, energy use and system size can be reduced by more of the 60 %.

Brager & Baker (2009) [78] performed a web-based survey in 12 buildings with mixed mode ventilation (with operable windows), compared with a database of over 43000 responses provided in 370 buildings, available at Center for the Built Environment (CBE). Thermal comfort, acoustics, air quality, cleanliness, lighting, office furnishing, spatial layout, maintenance and overall satisfaction were investigated. The following aspects were highlighted: (1) Hybrid approach consists in the use of some types of MV and/or cooling, combined with NV. (2) Most buildings in the CBE database (89 %) did not respect thermal comfort standards, with thermal environment satisfaction expressed by only 59 % of occupants on average. Too low air movement and lack of control were seen to be the main drivers of dissatisfaction. (3) Especially in terms of air quality and thermal comfort, HV buildings were found to perform extremely better than the benchmark buildings. On a scale from “-3” (very dissatisfied) to “+3” (very satisfied), mixed-mode buildings' thermal satisfaction was 0.94 points higher than in benchmark buildings. Additionally, air quality satisfaction was even larger (1.43 points higher). (4) In MMV buildings, a relationship was observed between air quality and thermal satisfaction and age of buildings (higher in most recent buildings) and climate (higher in moderate climates). (5) Causal mechanisms explaining trends in satisfaction would require more studies. Nevertheless, comments and previous research suggest people preferring operable windows because of a better personal control or the environment, fresh air perceived, major air movement and outdoor connection. The advantage of MMV buildings is that they offer these benefits and also high thermal control by mechanical devices. (6) Best performance buildings were observed to be the ones with MV only (no air-cooled systems) and radiant cooling. On the other hand, problems with the window interlock in changeover systems were associated with the lowest performance. The co-existence of NV and MV being able to work well together, with occupants able to ignore automated controls if desired or needed, was therefore pointed out. Moreover, occupants' comments indicated that MV - NV relationship does not always work as it was expected, having windows shut more than necessary.

Perino (2009) [131] performed an investigation about performance of buoyancy driven single-sided NV for IAQ management. This was done by means of measurements' series in a test lab (controlled environment) at the Aalborg University. Moreover, numerical models were used to assess different control strategies' effects, as well as thermal and IAQ conditions. The following aspects were pointed out: (1) Innovative NV systems, integrating NV devices like motorized louvers and windows with MV, seem to be more welcomed by occupants. (2) Single-sided ventilation driven by buoyancy is effective, being able to guarantee good air-change rates, allowing to control IAQ and temperature; (3) Models can be used for control strategies optimization, to obtain adequate IAQ and indoor comfort. Thus, NV with thermal regulation and air-change perspectives was considered.

In a University building in mild oceanic climate (La Rochelle, France) a comparison of NV and MV strategies was performed by Dhalluin & Limam (2014) [132]. In particular, in two adjacent classrooms, a comparison of four ventilation modes was performed: (1) NV on a single room side; (2) NV with a systems of control of air-temperature and presence-based window control ("Self Opening and Shading System" = SOS), with 22 °C and 500 lx as summer setpoints and 21 °C and 500 lx as winter setpoints. (3) HV of 250 m<sup>3</sup>h<sup>-1</sup> associated with NV

(manual windows only); (4) HV of  $250 \text{ m}^3\text{h}^{-1}$  associated with NV (SOS). A 40 % efficiency heat exchanger and a hot water battery made to supply a minimum of  $20 \text{ }^\circ\text{C}$  air temperature in winter were present. Ambient parameters were measured and comfort questionnaires administered to teachers and students during hot and cold season in 2010. The following aspects were highlighted: (1) In many classrooms, poor ventilation leading to poor discomfort, learning performance and health risks is often present. (2) NV provided satisfactory IEQ, comfort and consumption of energy when well controlled. In this sense, the best compromise between energy demand and satisfactory learning was provided by SOS-NV. (3) When extreme conditions were present (i.e., very humid, cold or hot climate, or noisy outdoor conditions), no adequate energy savings and thermal comfort conditions could be provided. Therefore, HV might be necessary. Still, in environments where occupation density is lower (e.g., family houses), this would probably provide too many heat losses due to the too high amount of fresh air. Nevertheless, it would be easier to install than a MV system and would be associated with a good perception of occupants. (4) Good IEQ, comfort conditions and energy savings were guaranteed in summer by SOS system. During the whole year, this system provided good air-change rate and  $\text{CO}_2$  conditions, even if particulate was slightly higher than with MV (because of the absence of filters). By means of windows, shadings control and night cooling action, SOS ensured a refreshment of  $2 \text{ }^\circ\text{C}$  in summer, as well as meeting the setpoints in terms of lighting and air temperature levels. Best IAQ and thermal sensation were also met with this system. The drawback was a higher heat loss and necessity of backup electric heating in winter. Moreover, during the cold season, occupants often switched to manual modes in order to contrast colder draughts. (5) NV only (the most common in educational French buildings), despite being the most energy efficient, provides the lowest IEQ due to low air-change rate. Besides, this strategy provides the best acoustic and thermal sensation conditions, also saving the 85 % of electric energy. (6) Mixed modes, even if providing the most satisfactory IEQ due to lowest  $\text{CO}_2$  concentration, provoked lowest comfort conditions and energy savings. Therefore, the lowest IAQ perception was given despite the best IAQ conditions in terms of  $\text{CO}_2$  and particle concentration. (7) Overall IEQ conditions were generally "satisfactory" and "quite satisfactory", meeting French standards in both subjective and objective approach. (8) Consistency between sensation scores and the parameters measured was observed ("slightly cold" in cold season and "slightly warm" in hot season), as well as in the odor perception ("low odor in winter and "quite good" in summer). Therefore, World Health Organization (WHO) recommendations were fulfilled. (9) Acoustic perception was also "quite good" for all modes. Nevertheless, warm sensations seemed to be better tolerated with SOS system. The intermittent noise generated by this system was also better tolerated than the continuous one by MV. (10) Indoor environment was seen to provide a higher satisfaction in winter, despite a better footprint classification in summer. (11) Air velocity, lighting level and relative humidity (RH) subjective evaluations were observed to be homogeneous for all the ventilation types in both seasons, due to low sensitivity by occupants concerning these parameters' variations, which generally met standards' requirements. (12) Subjective approach did not suggest to use MV, despite the higher air-change rate. A multi-criteria approach is then justified.

In 2015, Montgomery et al. [133] investigated the IAQ of an office space in Vancouver (Canada), designed to be operated with both the ventilation types. TVOCs (total volatile organic compounds),  $\text{CO}_2$  and PM in the space, with both NV and MV, were measured. It was observed that pollutants' concentration was more variable when using NV. Nevertheless, the concentration was still below thresholds from standards. On the other hand, higher control of pollutants' level was ensured by MV. NV air exchange rate was correlated with the TVOC concentration, while MV was not.  $\text{PM}_{2.5}$  indoor-outdoor ratios were noticed to be 0.87 and 0.5 for NV and MV, respectively. Efficacy of NV also depends on indoor materials (VOC emission), outdoor pollution, period of the year (occupancy) and outdoor air velocity. In general, use of HV instead of NV would allow to save energy, while ensuring to meet IAQ needs. Moreover, these systems would benefit from occupancy control, sensors to detect differences of pressure on the envelope, PM and regional meteorological data, better occupants-building control interaction to optimize strategies of control. It was finally highlighted that

investigations on sites with other systems of ventilation, outdoor air quality and types of building would be worth of interest.

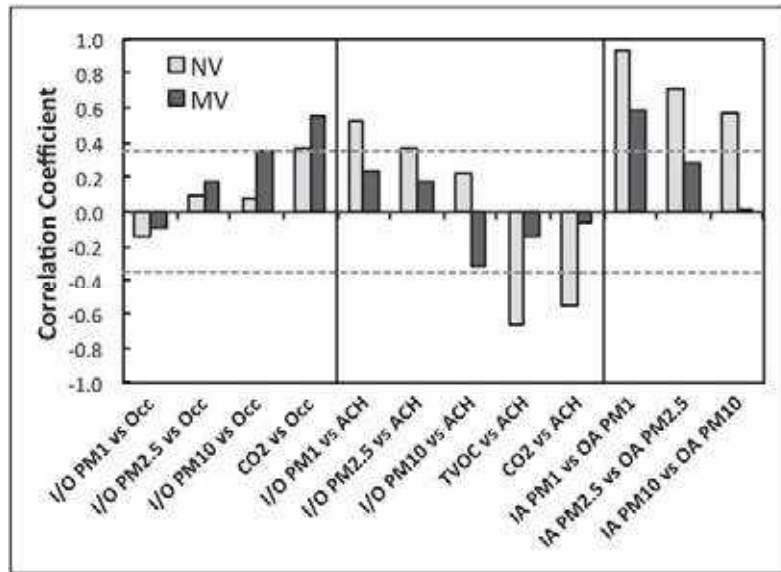


Figure 44: The correlation coefficient of Pearson between pairs of variables, 95 % confidence level indicated by dashed lines. Reproduced from Montgomery et al. (2015) [133].

In 2015, Daghigh [134] published a review about ventilation and thermal comfort in classrooms, residential and office buildings of Malaysia and the area nearby. It was firstly mentioned how, in order to obtain good IAQ levels, adequate ventilation system is necessary. On the other hand, too large amount of energy can be wasted by unnecessary ventilation. Moreover, energy efficiency can also enhance occupants' thermal comfort. On the other hand, NV could increase humidity levels and affect comfort in hot and humid climates. For this reason, MV and air conditioning use is broad in tropical climates. In this framework, the review concluded that, in hot-humid climates, the range of thermal comfort is wider than what is indicated in international standards, and that healthy IAQ and adequate ventilation strongly influence indoor thermal comfort sensation. In tropical climates, IAQ and thermal comfort could be improved (and energy consumption decreased) if more studies in the field would be performed. Findings could be exploited to modify building energy audits in order to obtain more energy efficiency. In the future, ventilation technologies and thermal comfort could be coupled with active and passive strategies and renewable energies. This would help overcoming building energy issues in hot-humid areas.

In 2016, a review by Salcido et al. (2016) [80] analyzed literature of 1996-2006 in order to understand the HV usage in offices, in terms of objectives, progresses fulfilled and challenges for the future. It was firstly stated that HV has been efficiently used to guarantee good indoor environment, since the alternation of MV and NV could save 75 % of the energy use, while 40 % of the energy could be saved by the optimization of windows' schedules. The following conclusions were listed: (1) Air quality, thermal comfort and consumption of energy are significantly influenced by occupancy and people behavior. (2) The design of HV systems by simulations is over-simplified in terms of occupants' behavior, and more advanced algorithms are needed. (3) In the future, HV should be optimized by proper design of layout of the building (internal and external), taking into account the direction and speed of the wind, and using the proper insulation, glazing, façade design and shadings. This would allow to minimize the use of MV cooling energy. (4) In order to improve the cooling systems' efficiency, better understanding of proper HV strategies depending on the climatic areas are necessary in the future. (5) Potentially higher energy savings can be obtained by users' education about thermal conditions and behaviors expected.

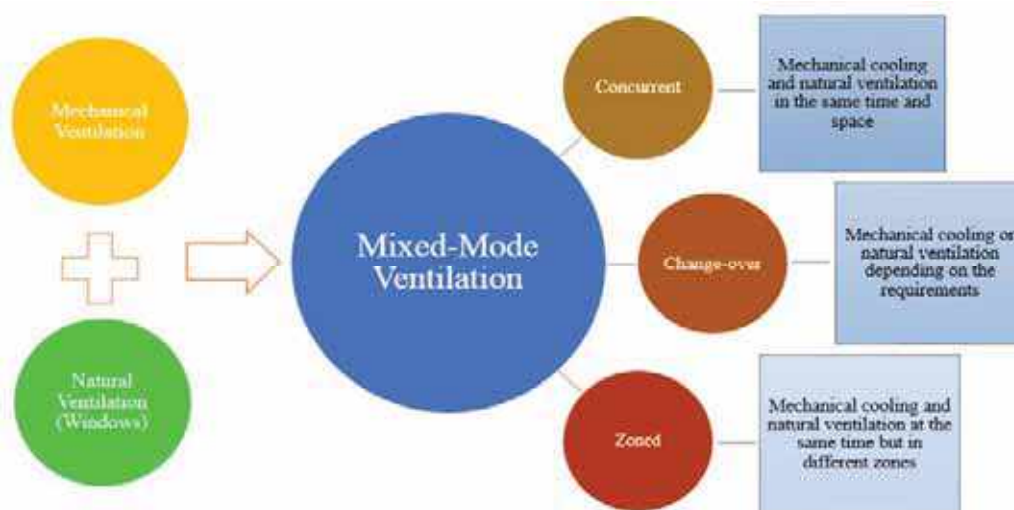


Figure 45: Types of HV systems, reproduced from Salcido et al. (2016) [80]

A review of standards, regulation, reports and scientific studies on energy efficient methodologies for ventilation, considering also occupants' behavior influence on energy use and correlation of ventilation with productivity and health, was published by Chenari et al. [91] in 2016. It was firstly highlighted how ventilation is the key both to provide suitable IAQ and to decrease the energy use. Following conclusions were stated: (1) HV leads to considerable energy savings, while ensuring acceptable IAQ levels. (2) Ventilation of spaces with low or absent occupancy annually leads to considerable energy waste in the world. (3) IAQ and buildings' energy performance are not only affected by characteristics of buildings, but also by methods of ventilation, environmental conditions and controlling behaviors of occupants. (4) Health issues and symptoms, as well as bad occupants' performance, might be provoked by poorly designed ventilation. For this reason, ventilation rates higher than minimum standard requirements are suggested by many studies. Nevertheless, the topic of relation of ventilation rate with indoor health should be further deepened in several types of buildings (offices, day care centers, schools, homes), in several climates and especially in outdoor polluted regions (where more attention to filtration and air cleaning should be paid). (5) Literature lacks of studies regarding HV strategies smart-window based. These strategies could help reducing the energy consumption while maintaining proper IAQ. (6) Energy consumption cannot be reduced under the levels at which discomfort and unhealth are caused to occupants. (7) nZEBs shift the assessment of buildings' energy consumption from a yearly scale to a daily scale, for a balance among demand, storage and production. In this framework, predictive and dynamic control of buildings, comprising HV, can become a winning strategy for a more efficient use of available energy.

Aldawoud (2017) [135] used CFD to study the behavior of several alternative configurations (size and orientation, solar shading) of inlet and outlet openings in a naturally ventilated standard office building in a hot-humid climate. The aim was to maximize wind-driven cross-ventilation by the most efficient design of windows. The paper stated that: (1) Acceptable thermal comfort conditions (thermal regulation perspective) and temperature can be achieved by cross-ventilation. (2) Not adequate outdoor temperatures (too high) and wind conditions (too low) may be present in summer in order to provide enough internal air movement to ensure thermal comfort. Nevertheless, 4 - 8 °C of temperature reduction are achievable. (3) In other seasons (November-April), NV is a valid alternative to air-conditioning. (4) Large inlets and orientations of inlets and outlets are directly proportional with the airflow rate. Larger inlets should be exposed to the main direction of wind. On the contrary, similar small areas of inlets and outlets led to a bigger resistance with lower differences of pressure and less air circulation. Therefore, an important effect on airflow is obtained



by building orientation. (5) Airflow is enhanced also by adding horizontal shading devices outside of the outlets. This has the effect of making the differences of pressure higher.

A comparative analysis of the air-change performance of MV and NV was made in two schools in Seville (Spain, dry-summer subtropical-Mediterranean climate) by Gil-Baez et al. (2017) [136]. Levels of humidity, CO<sub>2</sub> and temperature were analyzed in association with occupation, and data obtained were validated with simulations in a third building with cross NV. Here, stack ventilation was tested. The following aspects were pointed out: (1) Based on studies performed in cold climates, MV has been widely adopted in recently built schools, in order to overcome air-tightness to achieve adequate IAQ. Nevertheless, in mild climates the number of hours requiring a heating system is moderate, and near Zero Energy Buildings could be obtained by NV, without compromising indoor comfort. (2) In environments with high occupation and defined schedules (like schools) NV could provide the IAQ necessary for a proper learning environment and remove heat from internal gains such as windows and occupation. (3) Suddenly reduction of CO<sub>2</sub> concentration below the 1000 ppm limit was observed with windows' opening in winter days. Moreover, no parallel temperature reduction was observed. Since heating system was off, this means that internal gains were more significant than NV losses (positive effect of thermal inertia). (4) Usage of NV allowed energy savings between 11 % and 26 % and CO<sub>2</sub> emissions lowering of 31 % - 49 % with respect to MV. Moreover, the NV tested allowed draughts and heat losses to be minimized, due to less presence of air inlets. The socio-economic impact of using NV in schools of Mediterranean regions would be important, due to the high number (87000 schools) in Spain, Greece, France and Italy. This measure would save approximately 46500 tons of CO<sub>2</sub> only in the Andalusia area. (5) A proper design of NV systems, such as windows with automated control, is necessary, since they need to satisfy both energy savings and IAQ requirements. (6) When noise level is low and unpolluted environment is present, NV is a proper solution. Otherwise, with noisy locations or colder weathers, solutions of HV could be implemented (i.e., MV with heat recovery coupled with windows with an automatic control). (7) More research is necessary in mild and Mediterranean climate regions in order to promote the use of NV and develop commercial solutions.

A presentation of a strategy of building design using a HV system to provide energy efficiency measures in a Eighties social housing complex of Modena (Italy) was provided by Barbolini et al. in 2017 [137]. MV (with heat recovery and earth tubes) was used during the heating season. On the other hand, free running use (open trickle ventilators on windows, vertical shaft ventilators, mitigation of heat loads by means of insulation and mass, free night cooling) were used during the non-heating season. Aerodynamic principles to maximize pressure differences due to stack effect were implemented for vertical shafts. Combined heat and power system, solar thermal collectors, PV and solar panels were also used to further minimize the energy demand. Indoor comfort was assessed by the adaptive model during the warm season, and was verified with CFD modeling. It was found out that, in warm season, acceptable indoor conditions can be met in a free running net-zero energy building. For this reason, conversely than the current tendency of using HVAC during hot season, HV ventilation can be suggested, with NV in summer and MV in winter.

In a baseline simulated office building with two floors, a model predictive control (MPC) was built by Chen et al. (2018) [83] in three climate zones of the USA (Atlanta, Los Angeles and San Francisco). The aim was to maintain acceptable indoor conditions with energy consumption minimization, when using HV. Validation showed that occupants' thermal comfort was maintained by MPC, which was therefore performing as expected.

Usman & Bakar (2019) [138] analyzed thermal comfort of a residential premise in Malaysia by means of CFD analysis. The effect of adding a ceiling fan MV system assisting NV was assessed. It was noticed that, by adding this system, there was an improvement in the values of PMV and PPD indexes.

Raji et al. (2020) [82] used CFD and EnergyPlus in order to study six NV strategies in on 12<sup>th</sup> floor of a 21-storey office building in Delft (Netherlands, temperate maritime climate). It was observed that thermal

comfort and fresh air were guaranteed for up to 90 % of occupancy time during summer by NV strategies, and therefore a high share of energy can be saved with this strategy. The different strategies had similar performance, except than the ones combined with a poorly ventilated double skin façade or with atrium design. In fact, double skin façade was observed to have the risk to become too cold or too warm, making it necessary to have a building management system to control vents operation. Minimum temperature set-point is important for windows operation and thermal comfort. For this reason, it needs to be correctly set according to outdoor variations of temperature. Scenarios with vertical shafts (atria or solar chimneys) did not show advantages with respect to the scenarios driven by wind. This might be due to the office geometry (narrow plan) and location (city with high wind velocity along the year). In fact, highest advantages of stack ventilation occur with buildings with a deep plan, where it is difficult for cross ventilation to occur. It was finally highlighted how structure associated or architectural configuration limitations exist for improving or adding NV to existing buildings. Moreover, applying night-time NV during summer could even extend the percentage of hours with comfort conditions. For high-rise buildings, HV is necessary when suboptimal external conditions (wind, temperature or noise) and design failures (architectural design layout or tenancy patterns change) are present.

An investigation on the performance of hybrid ventilation in industrial buildings was performed by Meng et al. (2020) [81], by means of experimental scale model with a heat source in Xi'an University (China). Hybrid NV driven by buoyancy coupled with a mechanical system for exhaust was used. At different velocities of the mechanical exhaust, efficiency of the HV and distributions of temperature were observed. After highlighting how indoor environment and ventilation energy can be optimized by means of HV, the study concluded that an optimal velocity needs to be identified in order to maximize HV efficiency, since non-optimal thermal environment and airflow short circuiting, as well as excessive energy consumption, can be created by a disproportionate MV rate.

Torresin et al. (2021) [139] performed an online survey among 848 people working from home during the COVID-19 pandemic in London and Italy, during winter lockdown. A focus on the perception of the acoustic environment while relaxing or working and on the elements influencing the window opening behavior was given. The HVAC typology did not give any significant difference in soundscape appropriateness for relaxing, and the ventilation strategy did not give any significant difference in soundscape appropriateness for working. Nevertheless, in general, during working and relaxing activities, spaces with less dominant noises from building services were judged as more appropriate. No significance associated with the sky or building view, noise sensitivity, presence of a quiet side, gender and age were found in the windows opening behavior while working from home. Even if in noisy urban areas, occupants tended to keep open windows at least sometimes when using NV or MMV. In Italy, participants working from home were more inclined to open windows when a vegetation view was present. Moreover, higher noise levels were compensated by other benefits from NV in the windows opening behavior. This suggested the idea of the existence of an "adaptive acoustic comfort" in NV facilities [140], [141], to be further investigated in order to define acoustic opportunities for NV in buildings. In fact, elements such as the perception differences between MV and NV and the presence of pleasant outdoor acoustic contexts are not taken into account in present standards.

An empirical study about the change of classrooms environmental conditions during COVID-19 pandemic was performed by Monge-Barrio et al. (2022) [142]. Surveys were conducted during the heating seasons of 2020 and 2021, in nine naturally ventilated secondary/high schools of Pamplona (Spain). Moreover, a detailed building monitoring was implemented in one of the schools. When present, MV was not used due to the high noise produced and the high consumption of energy, so all the facilities were only naturally ventilated during both the periods considered. A mean CO<sub>2</sub> concentration reduction of 1400 ppm (1000 ppm observed) and a mean temperature reduction of 2 °C (18 °C observed) were noticed, with a 31 % increase of the heating energy consumption. The authors highlighted how these lower temperature values can be admissible only during a pandemic situation, without vaccines' availability. Moreover, they stated that a plan should be

prepared by schools, in order to improve indoor conditions, with cross ventilation and installation of CO<sub>2</sub> and temperature monitoring systems. When outdoor conditions require it, complement Heat Recovery Ventilation and thermal envelope improvement would also help in providing healthy and safe classrooms with low CO<sub>2</sub> emissions and low consumption of energy. Therefore, the effects of NV used for air-change were studied with both an IAQ and thermal comfort perspective.

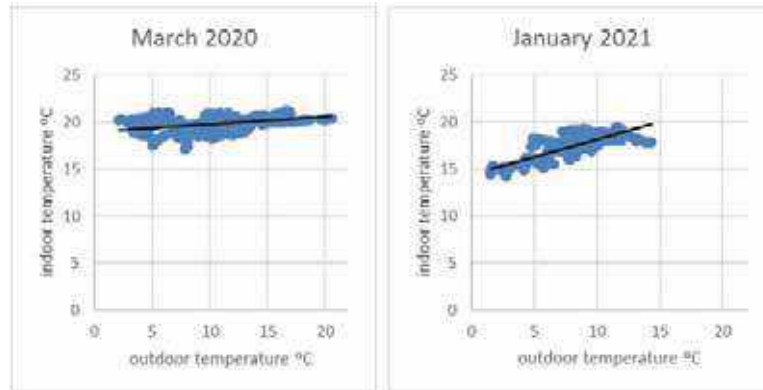


Figure 46: Comparison of temperatures measured in March 2020 and January 2021 as function of outdoor temperature, reproduced from Monge-Barrio et al. (2022) [142]

Another research on an educational building was conducted by Elnabawi & Saber (2022) [143]. The authors evaluated an integrated HV (exploiting NV without compromising comfort) and photovoltaic (PV) system in urban facility in Bahrain (hot-arid climate). The performance was assessed by means of yearly energy savings and CO<sub>2</sub> emissions, as well as the potential to provide comfort on a thermal point of view (thermal regulation perspective). The analysis was made by a dynamic simulation validated using annual consumption data. It was observed that overheating hours (or cooling hours) can be reduced of the 23 % by the automatic operation of windows. Moreover, HV had a better performance in the cool season (33.5 % savings vs. 17.1 % in summer). The annual reduction is equal to 23 % with the hybrid ventilation, and 85 % when adding the PV solar system as a primary energy source. Finally, it was highlighted how extending the upper and lower comfort limits (from 25 °C to 22-29 °C) led to higher energy savings. This can be further enhanced setting the temperature according to the local climate condition instead than using setpoints from international comfort standards.

An evaluation on the particulate matter (PM<sub>2.5</sub>) and CO<sub>2</sub> in seven naturally ventilated and three mechanically ventilated residential buildings was performed by Yin et al. (2022) [144] in China (Xi'an, cold climate and generally serious pollution). This was made by means of a long-term online monitoring (one year). It was observed that, in the most polluted season (winter), NV was not able to remove PM<sub>2.5</sub> harm for humans: MV was necessary. A significant improvement in air quality could not be obtained by short-term MV if compared with NV, but results improved when the operation duration increased (minimum daily recommendation of 9 hours). The excess of CO<sub>2</sub> concentration (more than 1000 ppm) was greater with MV (26 %) than with NV (9 %). Moreover, a dependence of CO<sub>2</sub> concentration from indoor-outdoor temperature difference was observed. In Xi'an residential buildings, IAQ control could be implemented with a MV system combined with short-term NV in order to both control PM<sub>2.5</sub> and CO<sub>2</sub> concentration.

Arata & Kawakubo (2022) [145] performed measurement and questionnaire surveys in an office building of Tokyo (humid climate with hot and humid summers and dry and sunny winters with strong North-East monsoons), in order to test the effects of HV on energy consumption, thermal comfort and productivity during springtime (average temperature of 21 °C). The productivity effects were studied by means of a hierarchical linear model (multi-level analysis). The following considerations were made: (1) Mixed mode can decrease the power consumption while improving workers' satisfaction. (2) Windows' opening time

depended on weather conditions, varying each day. (3) On floors with HV, savings in the range of 3.1 - 70.6 % were present with respect to floors with MV only (both the systems maintained similar levels of air temperature and PMV). (4) Male participants' productivity improved of 9.1 %, probably because of decreased concentration of CO<sub>2</sub> and higher air flow and air freshness. (5) Since women productivity increased only of the 0.5 % with HV, gender differences might be present. However, a bias could have been given by the small number of female participants.

#### 5.2.4. *Studies not clearly stating a preference*

Kalamees (2006) [146] monitored the ventilation (measuring exhaust air flows) and the indoor climate (measuring temperature and RH in living rooms, bedrooms and outdoors) of 28 single family lightweight timber-frame houses in Estonia (Nordic climate). The monitoring was performed continuously during 1 year. Questionnaires (one per house) were also administered to occupants. During the hot season, high indoor temperatures highlighted that original design did not consider thermal comfort requirements. Problems in control systems were shown by large temperature variations in winter. Moreover, average daily amplitudes of RH and temperature were strongly influenced by the ventilation performance. Average air-change rates were lower than recommended by standards, but similar to ones measured in other Nordic countries. Questionnaires highlighted that NV was associated with stuffy air, while MV caused noise issues (which limited its use). Moreover, houses with air leakages in envelope caused cold floors, draught from electric sockets and fluctuating room temperatures during winter.

Ouyang et al. (2006) [147] performed a spectral analysis in five different outdoor locations (building roof, open area outdoor, around buildings, seashore and indoor) to find the characteristics of mechanical and natural wind on the dynamic point of view. It was found that, when mean velocity is not higher than 0.25 m/s, diffusing mechanical wind can reach the characteristics of natural wind. Reaching these characteristics (spectral characteristics of natural wind) can improve occupants' feeling about mechanical wind.

In 2011, Razman et al. [148] performed a field study in a University hostel in Malaysia (hot and humid climate), in order to identify if thermal comfort can be reached with NV. Measurements were taken for five days between 11:00 and 17:00 and 178 questionnaires' sets were collected. NV helps going for a sustainable environment and saving energy. Thermal condition was perceived as comfortable, but MV would help to make this condition more effective. Thermal comfort was somehow prevented by furniture arrangements and window openings which were an obstacle for adequate air movement.

A review on UK guidelines and regulations in relation to MV systems with heat recovery and a review on the long-term indoor VOC concentrations in super-energy-efficient test houses (considering the effectiveness of trickle ventilators and heat recovery ventilator use) were performed by the study of Yu and Kim (2012) [149]. It was stated that possible high indoor pollution from building materials' emissions and products from combustion can occur in air-tight buildings. Moreover, it was expressed the need to review and examine the several ventilation possibilities to alleviate the indoor pollution while ensuring energy savings. Possible options would be low emission materials or use of air-cleaners to decrease the need of higher air-change rate and thus improve energy savings.

Giridharan et al. (2013) [150] investigated the performance of spaces with MV but passive cooling in a nucleus-type hospital (connected cruciforms blocks with various and little courtyards in between, Figure 4739) in Glenfield (UK). A comparison between thermal comfort criteria and measured temperatures was made during summer 2010, while a prediction of future conditions in ward space was made by means of a calibrated model. The following conclusions were listed: (1) The maximum indoor temperature varied in the range of 27.3 - 29.3 °C, and the nurse station was found to be the warmest zone. Most spaces monitored were found to be within HTM03-01 [151] thresholds in terms of thermal comfort. (2) There is need for



adaptive criteria accommodating both cooling and heating conditions, specific for hospitals. (3) The incidence of night-time overheating showed major deviations from criteria of thermal comfort. (4) MV with  $1.5 \text{ ach}^{-1}$  would provide reasonable conditions of comfort, if good provisions of openings of windows are present. (5) Light touch low carbon interventions may give comfortable conditions in bedrooms in UK Midlands into the 2050s in nucleus-type hospitals, for both extreme and typical years.



Figure 47: Glenfield Hospital aerial view. In yellow the case study wards and waiting area locations. Reproduced from Giridharan et al. (2013) [150] (Source: Google Earth image modified [152])

A building model was built by Homod & Sahari (2013) [153] in Malaysia, by means of empirical and physical subsystems model functions. The aim was to focus on the building internal temperature and RH control efficiency by infiltration and ventilation. PMV (as function of HVAC controlled indoor air velocity, temperature and RH) was used to characterize indoor thermal comfort. Twenty-four hours MV simulations with varied flow rate were performed. While highlighting the advantages of MV in guaranteeing thermal comfort, the results point out the possibility of reducing the relying on powered cooling.

Natarajan et al. (2015) [154] used a simultaneous survey among 115 participants and indoor and outdoor measurements, in order to study the applicability of (1) PMV/PPD model (ISO 7730:2005 [155]), (2) adaptive model (ANSI/ASHRAE Standard 55:2013 [156]) and (3) adaptive model (EN Standard 15251 [157]) to assess thermal comfort. The research was performed in three different offices of Bogotá (Colombia, subtropical climate) having three different ventilation regimes (NV, MV and HV). Adaptive and PMV model from Standard 55 was observed to be functional for predicting thermal perception in MV buildings. On the other hand, in NV and HV free-running offices, adaptive models in ASHRAE and EN standards showed less applicability. This was due to a reduced personal control on windows in the two offices part of the survey. PMV model was able to assess conditions of comfort in the HV office, where control conditions were comparable to the MV one. Finally, PMV/PPD and adaptive models' applicability was seen to be strongly dependent on the control possibility which is given to the occupants. For this reason, a classification of environments based on windows' control level (instead of only considering the air conditioning presence) was proposed.

In order to achieve the net zero energy balance, various criteria of ventilation were implemented by Grigoropoulos et al. (2016) [158], in a simulative study (EnergyPlus) of a residential building in a Mediterranean climate (Thessaloniki and Athens, Greece, and Larnaca, Cyprus). In these areas, hot summers



are present, with cooling loads prevalent on heating ones, and PV systems are applicable due to high solar irradiance. The base case model scenario was characterized by an air-change rate of 2 air-changes per hour (ACH) during night and early morning. The ventilation rate was gradually increased, also simulating MV, assessing the PV capacity, the primary energy demand and indoor thermal comfort. It was observed that an increase of the ventilation rate to 8 ACH provoked a minor primary energy demand. The energy reduction was never higher than 10 %, and was slightly more marked in Thessaloniki, because of the presence of a milder climate. Moreover, the application of higher rates of ventilation had an even higher impact on thermal comfort, allowing to obtain a 50 % decrease of overheating degree hours in Athens, and a 30 % reduction in Larnaca. MV provided a major control of indoor temperature, but increased the energy demand (20 %) and costs for maintenance. For these reasons, this solution is less applicable in residential buildings in Eastern Mediterranean climates, when microclimate conditions permit the exploitation of night-time ventilation. Other issues (like safety, noise, life cycle costs and feasibility) should be considered when deciding the best solution. In larger multistorey commercial or residential buildings, HV or MV ventilation could be necessary, due to the need of more complicated ventilation techniques for achieving energy savings.

Nardell (2016) [159] provided with a review on the state of possible environmental interventions to overcome the problem of tuberculosis transmission. It was highlighted that interventions to control this illness can also apply to other airborne transmittable diseases. Moreover, measures of environmental control are the most important way of intervention after the identification of unsuspected cases. In fact, transmission is facilitated in overcrowded, congregate and badly ventilated buildings (e.g., prisons, hospitals, refugee camps). Generally, NV is the main air disinfection way, with the advantages of being cheap and broadly available. The drawbacks are the inapplicability under too cold or too hot conditions or other conditions (windows might be closed, for instance, for pest control or security reasons). Moreover, when air conditioning is installed, windows might be kept closed to ensure thermal comfort. MV has the advantage of providing proper disinfection of air, but it might be expensive in the installation, operation and maintenance. Finally, upper room germicidal irradiation was identified as the most cost-effective mean of disinfection.

Lei et al. (2017) [160] monitored the IAQ ( $O_2$ ,  $CO_2$ , temperature and RH) in a students' dormitory of Beijing during winter (January). Questionnaires' surveys were used to analyze mental state and thermal comfort after 7 hours sleeping. A model predicting temperature and IAQ while varying the open area during winter was proposed. The study also aimed to prove that, in dormitories, NV is necessary even in cold climates. It was concluded that increasing the NV area improved IAQ, but decreased thermal comfort. During winter,  $0.055 \text{ m}^2$  (giving  $0.036 \text{ m}^3/\text{s}$  of NV) was found to be the proper area of ventilation in dormitories with  $10\text{-}12.5 \text{ m}^3$  of space per person. With open area bigger than  $0.077 \text{ m}^2$ , the temperature decreased under  $20 \text{ }^\circ\text{C}$  only after 4 hours. An increase in the students' number should be accompanied with an increase of the open area. Nevertheless, with less than  $6.5 \text{ m}^3$  per person, windows' opening is insufficient.

Heebøll et al. (2018) [161] performed a four weeks monitoring of four different Danish classrooms (Atlantic temperate climate) in the winter season (January), one year after a retrofitting was performed. Temperature,  $CO_2$  concentration, use of energy and behavior in door and windows opening were recorded. The rooms, located in Copenhagen, were equipped as follows: (A) decentralized, balanced supply and exhaust MV unit with heat recovery; (B) automatically operable windows with an exhaust fan; (C) automatically operable windows with alternating counter-flow heat recovery through slots in the outside wall; (D) visual feedback display unit showing the current classroom carbon dioxide concentration, thus advising when the windows should be opened. Original approach of manual windows opening was retained in one class, for comparison. The paper allowed to list the following observations: (1) The presence of a  $CO_2$  feedback display caused the opening time to be longer (during occupancy hours including breaks), but this did not cause the decrease of  $CO_2$  concentration to be significant. (2) With automatic opening and exhaust fan, the opening period was 71 % of occupancy time (breaks included), also causing  $CO_2$  concentration to be significantly lower with respect to classrooms with only manual operations. (3) With automatic opening and heat recovery, opening period

was 49 %, with no significant lower CO<sub>2</sub> concentration with respect to "only-manual" rooms. (4) In the rooms with MV and with automatic windows and the exhaust fan, the lowest concentrations of CO<sub>2</sub> were measured. (5) No remarkable differences were observed in indoor temperatures of classes with automatic opening of windows and classes with no retrofit. Temperature was generally within comfort ranges in both cases. A significantly warmer temperature was observed in rooms with the display for visual CO<sub>2</sub> feedback or with MV (maybe caused by a valve defect and radiator thermostats' setting). (6) In temperate areas, MV or automated windows opening systems are recommended for classrooms.

An investigation on the use of MV and NV in 46 apartments in 10 cities in China, located in 5 different climate zones (severe cold, cold, hot summer cold winter, temperate, hot summer warm winter), was performed by Lai et al. (2018) [162]. The houses were monitored for one year, and questionnaires were administered to gain information about residents' choices. It was stated that MV, even if more controllable, reliable and comfortable, could generate secondary air pollutants, noise and energy consumption. Moreover, it was found out that average ventilation duration was shorter for MV (7.2 hours vs. 11.0 hours). NV duration increased and MV duration decreased with: warmer climates, warmer season and higher average outdoor temperatures. In colder regions, when temperature reached 24 °C, NV duration began to decrease. When dealing with colder climates, use of supply MV was less than energy recovery ventilation systems, probably due to thermal discomfort. Moreover, MV and NV durations were highly variable and people were not active in the change of the status of ventilation. Noise was reported as a source of discomfort both in case on NV (outdoor) and MV (system). Finally, it was observed that the priority of occupants was thermal comfort instead than healthy IAQ. Nevertheless, when MV allowed to provide healthy indoor conditions, they stated their willingness to spend money on energy. Thus, energy savings, health and thermal comfort were proposed to be the three drivers of ventilation behaviors.

MV and NV effects on indoor climate (thermo-hygrometric and IAQ, thermal regulation and air-change perspectives) of nine homes in Urumqi (China, temperate continental climate with severely cold winters) was investigated by Zhao et al. in 2018 [163], by means of preliminary questionnaires on living habits and one-year indoor monitoring. Four of the houses considered were equipped with NV, four with MV with heat recovery, and one with MV without heat recovery. It was observed that winter indoor climate was dry, but comfortable during the rest of the year. In this season, MV was observed to possibly cause a lower temperature reduction and a lower humidity reduction with respect than a 25 minutes long NV. Both MV and NV would need attention to humidification, especially in the colder season. Moreover, indoor conditions were perceived drier by people living in environments with MV, who also expressed preference for humidifying the rooms: this did not prevent humidity to be lower than in houses with NV. In houses with NV, IAQ was observed to worsen because of too humid conditions when poor ventilation was present. PM<sub>2.5</sub> concentration was low outside in summer and transition seasons. Moreover, not too hot or too cold temperatures were present. These last aspects make it suitable to improve indoor environmental conditions by NV, saving MV energy.

Fernández-Agüera et al. (2019) [164] studied IAQ and thermal comfort in two different climates in Spain (Seville and Madrid). The investigation was conducted in residential buildings constructed before regulations on energy efficiency (1939-79). The case studies were not equipped with a MV system and had various levels of air-tightness. The IAQ was compared with the air-tightness and a comparison of the behavior in day- and night-areas was performed. It was firstly stated that, in these buildings, NV behavior (and therefore outdoor temperature) was the main driver for the air-change. Indoor-outdoor concentration of CO<sub>2</sub> were similar in spring, summer and autumn in Seville, and only in summer in Madrid. In Seville, this was associated with the behavior of occupants trying to lower the temperature during less irradiated times. In Madrid, poorer thermal comfort was also detected during summer. In both climates, during winter, levels of CO<sub>2</sub> above 1200 ppm were recorded in both Madrid (1900 ppm) and Seville (1400 ppm). Higher values were recorded during night. During this season, occupants, being aware of the lack of the MV, ventilated their flats mainly in the

morning, primarily relying on infiltration during the rest of the time. This was the main reason why unhealthy indoor air and poor air quality (both in terms of CO<sub>2</sub> and RH levels) were observed. In fact, low air-change rate and air-tightness both concur in creating high concentrations of CO<sub>2</sub>. In areas with warmer climates, this association is less evident, due to the major influence of individual behaviors in terms of ventilation. Healthy conditions could not be maintained, with the consequent risk of condensation, especially in colder climate (Madrid) and in buildings with the highest air-tightness (where windows had been substituted). The practice of windows' openings was observed to cause also a loss of energy. Improvement of ventilation practices and MV systems would ameliorate the IAQ in both locations. In Seville, comfort standards could be met raising winter internal temperatures by means of a more effective heating.

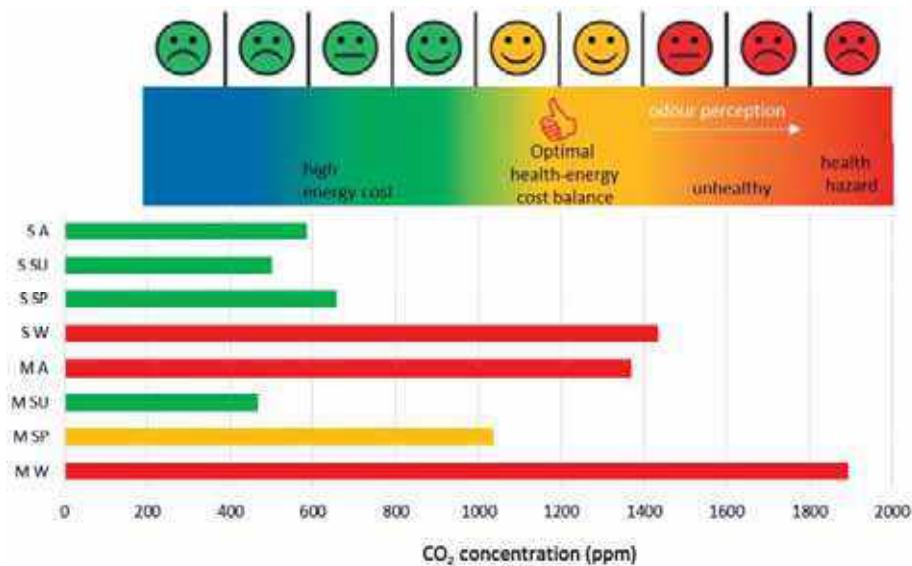


Figure 48: IAQ and balance with ventilation energy consumption. S = Seville; M = Madrid; A = autumn; SU = summer; SP = spring; W = winter. Reproduced from Fernández-Agüera et al. (2019) [164]

Cardoso et al. (2020) [165] used transient simulations in order to compare scenarios with different possible air paths configurations in a Portuguese apartment with highly permeable envelopes and highly variable air-change rate. Both natural and mechanical scenarios were included. A MEV (mechanical extraction ventilation) was present in bathroom and kitchen. On the other hand, unintentional air leakage paths constituted the source for air supply. Only when the MEV was on, a sweeping effect from bedroom to bathroom was observed. Moreover, equivalent air leakage area distribution through different leakage configuration paths was impactful on the air-change rate. It was concluded that the dependence of air-change rates from air-tightness is worth to be studied in Southern Europe, since NV is widely used. IAQ, energy efficiency and comfort strongly depend on it.

Abdul Hamid et al. (2020) [55] monitored air temperature, air humidity, air-change rates and CO<sub>2</sub> in twelve heritage buildings with offices of Sweden. Measurements were coupled with questionnaires to the occupants. The effects of a MV ventilation system with a heat recovery located in a chimney pot (hidden) and of dampers for air-change rate reductions (installed on the pathways for natural airflows, on the chimney tops) were studied. This was done by means of field measurements and energy simulations in two of the buildings. It was observed that, in this type of building, indoor climate is highly dependent on outdoor conditions. In fact, air-change rate is higher during working hours (window openings), higher during working time in summer than in winter (window openings), lower during after-hours in summer than in winter (smaller indoor-outdoor temperature difference). Too cold and draught conditions were observed in cold season, while too warm, dry and stuffy environments was seen in summer (with acceptable CO<sub>2</sub> conditions). Moreover, the two proposed solutions were observed to give a potential reduction in the energy use (also

CO<sub>2</sub> concentration in case of chimneypot MV with heat recovery). Finally, the authors recommend to make other investigations, specific for each building (e.g., thermography with air-tightness testing, emissions, particulate and moisture safety assessments), before taking decisions on the measures to apply. Profitability of measures should be taken into account, as it is fundamental in decision-making processes.

A real-time investigation of PM<sub>2.5</sub> and CO<sub>2</sub> concentrations in 33 classrooms located in 21 different schools of Beijing, comparing MV systems and NV with air cleaners, was performed by Cai et al. (2020) [166]. Air temperature, humidity and effectiveness of air-cleaning were also monitored. Too low ventilation rates were observed with NV in days of high PM<sub>2.5</sub> concentration. Nevertheless, both NV and MV were not sufficient to lower enough the PM<sub>2.5</sub> concentration. MV ensured temperature to be not too low during winter. Nevertheless, during days of central heating switching on or off, indoor temperature was found to be sometimes lower than the 18 °C recommended by Chinese standards, with both NV and MV. NAI (negative air ion) purification modules were observed to tend to elevate the levels of biomarkers related with a higher possibility of oxidative stress. MV had a lower energy efficiency in removing PM<sub>2.5</sub>, but was more effective in the CO<sub>2</sub> reduction.

Scheuring & Weller (2021) [167] performed an EnergyPlus simulation in an office room, in order to study the comfort and energy implications of four strategies of window openings (based on CO<sub>2</sub> and temperature) and one intake/exhaust MV system (based on CO<sub>2</sub>), at the three different climates of: (1) Wiegendorf (Germany) - moderate (European continental); (2) Madrid (Spain) – Mediterranean; (3) Hanoi (Vietnam) – subtropical. The paper led to the following considerations: (1) NV can be an alternative to save energy in non-residential buildings, ensuring less costs of maintenance and positive psychological feelings of freshness of air. Nevertheless, NV might lead to higher energy consumption and less IAQ, due to behavior of users. Therefore, controls of NV based on concentration of carbon dioxide and room temperature are needed. (2) In the cold months at moderate climate, long openings could not be used due to thermal discomfort. In the other conditions, NV outperformed MV.

The review by Wolkoff et al. (2021) [47] investigated the influence of microclimatic parameters (room temperature, indoor air humidity, ventilation) on human health, cognitive performance, infection risk and work in offices. It was highlighted that acute and chronic health issues can be reduced by ventilation, which can also enhance the work performance. This is due to control strategies of general emission source and the indoor air pollutants (comprising pathogens) dilution. MV helps diluting and removing the indoor air pollutants, thus giving better comfort and less health risks. When devices like efficient filtration and air cleaning systems are implemented, also exposure to size dependent ambient particles can be reduced. Satisfaction on thermal comfort and overall microenvironment is improved by personal control of ventilation, due to positive physical and psychological impact. Nevertheless, an increased exposure to air pollution, pathogens and allergens (from indoor or outdoor) can occur due to ventilation itself, being cause of health risks. This happens with NV or when not properly designed, maintained or operated MV is present. Deterioration of IAQ perception and harm from new chemicals exposure can also occur due to ozone surface-initiated reactions from systems maintained improperly. Moreover, in the cold season, dry outdoor air can enhance the viability of virus droplets: high ventilation rate with no humidification has to be avoided. Therefore, WHO's air quality guidelines should be met by a "health-based ventilation rate", with an acceptable perception of IAQ by diluting human bio-effluents.

### 5.3. Further statistics about literature analysis

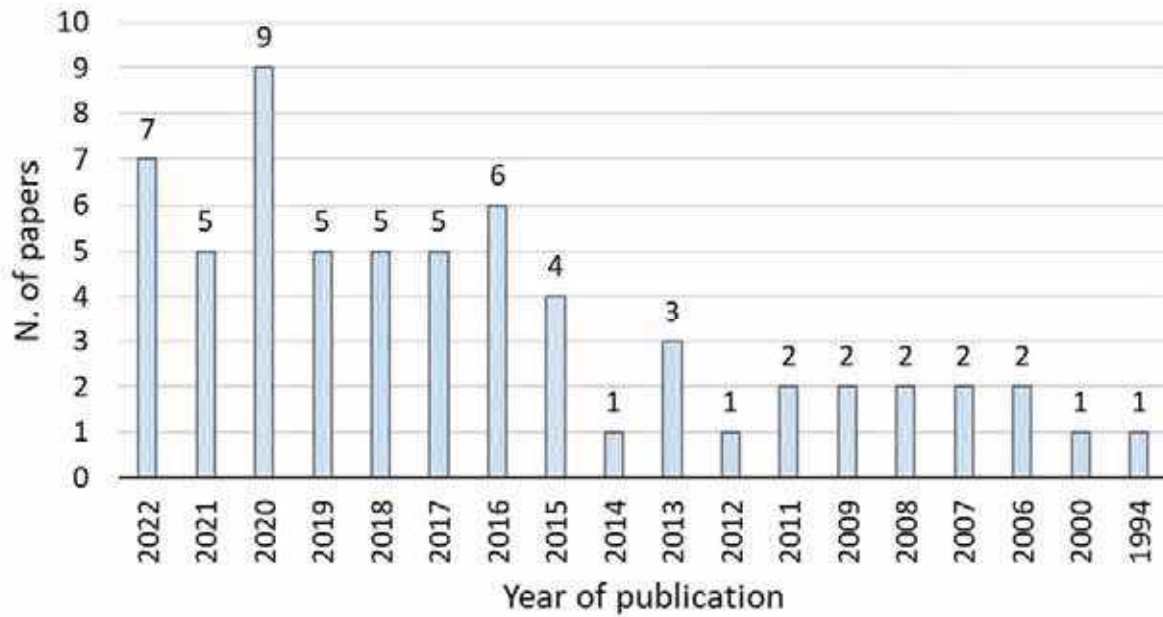


Figure 49: Number of articles for each year of publication

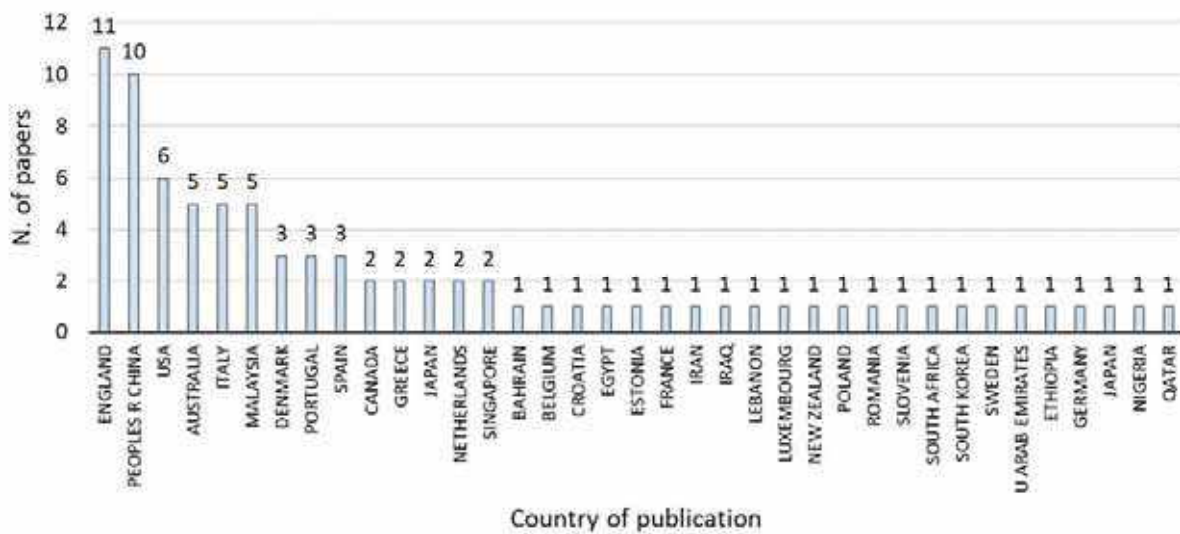


Figure 50: Number of articles for each publication country/region



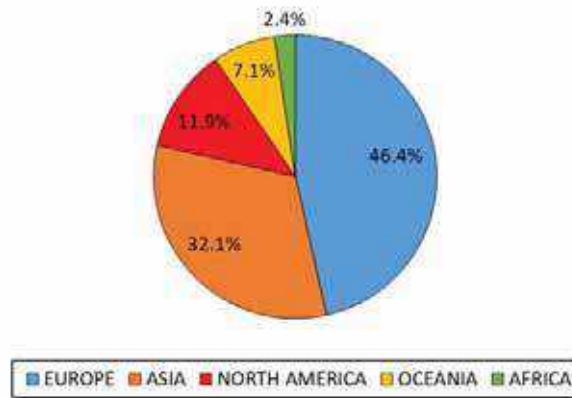


Figure 51: Percentage of articles per continent

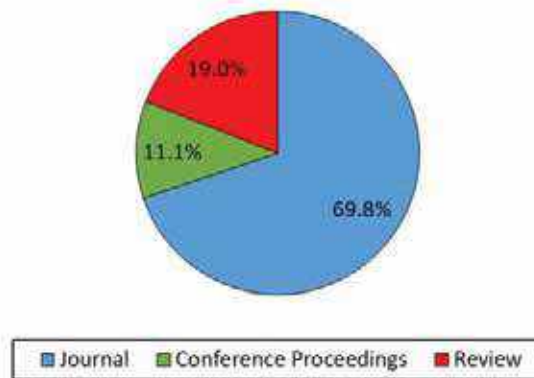


Figure 52: Percentage of articles per type

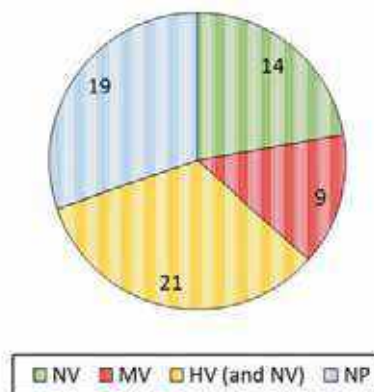


Figure 53: Number of articles per type of ventilation recommended. NV = natural ventilation; MV = mechanical ventilation; HV = hybrid ventilation; NP = no clear preference

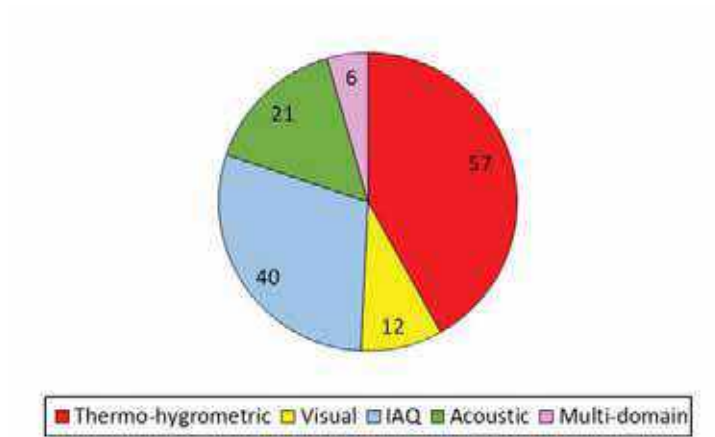


Figure 54: Number of papers treating each comfort domain

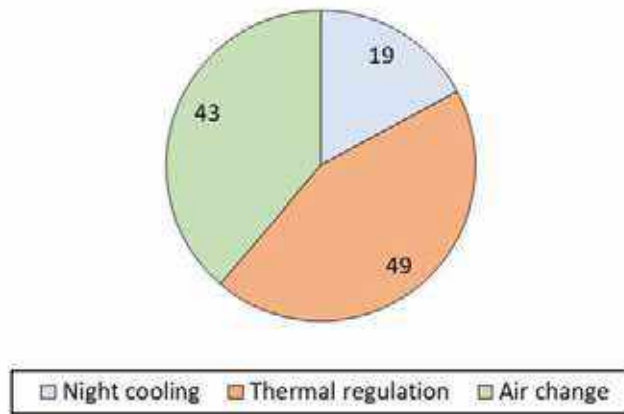


Figure 55: Number of articles considering each ventilation aim

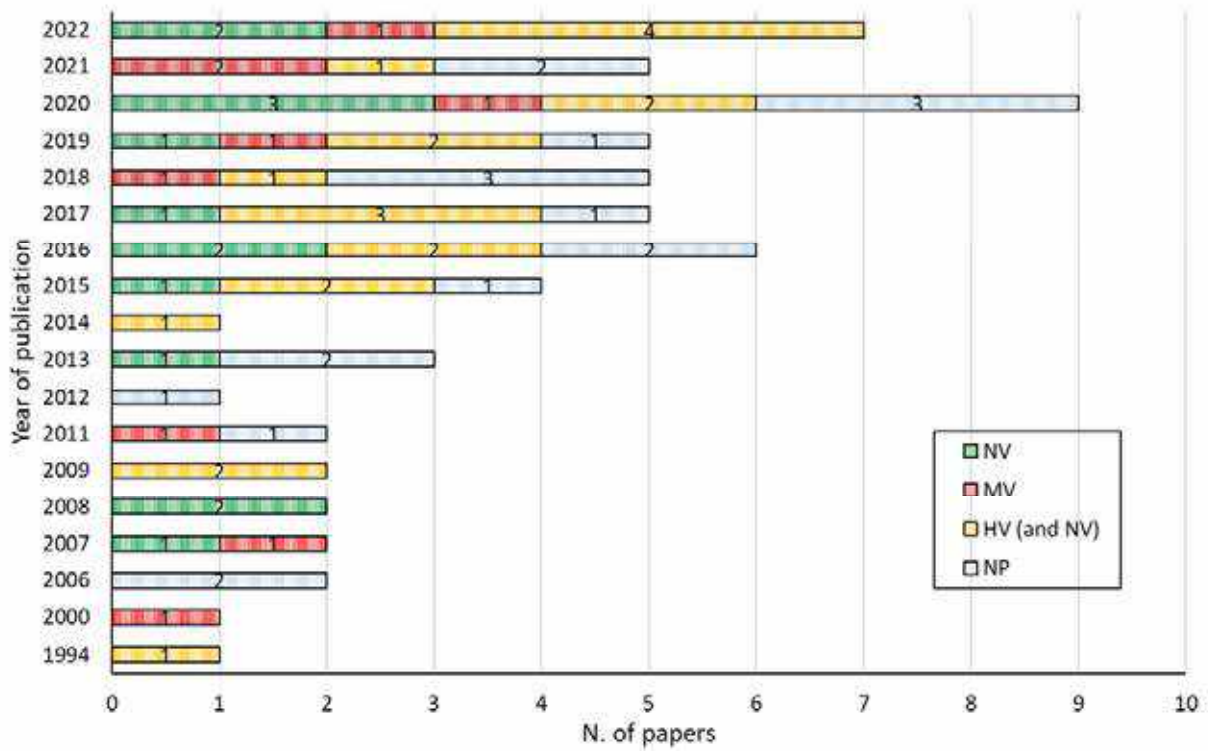


Figure 56: Association between publication year and type of ventilation recommended

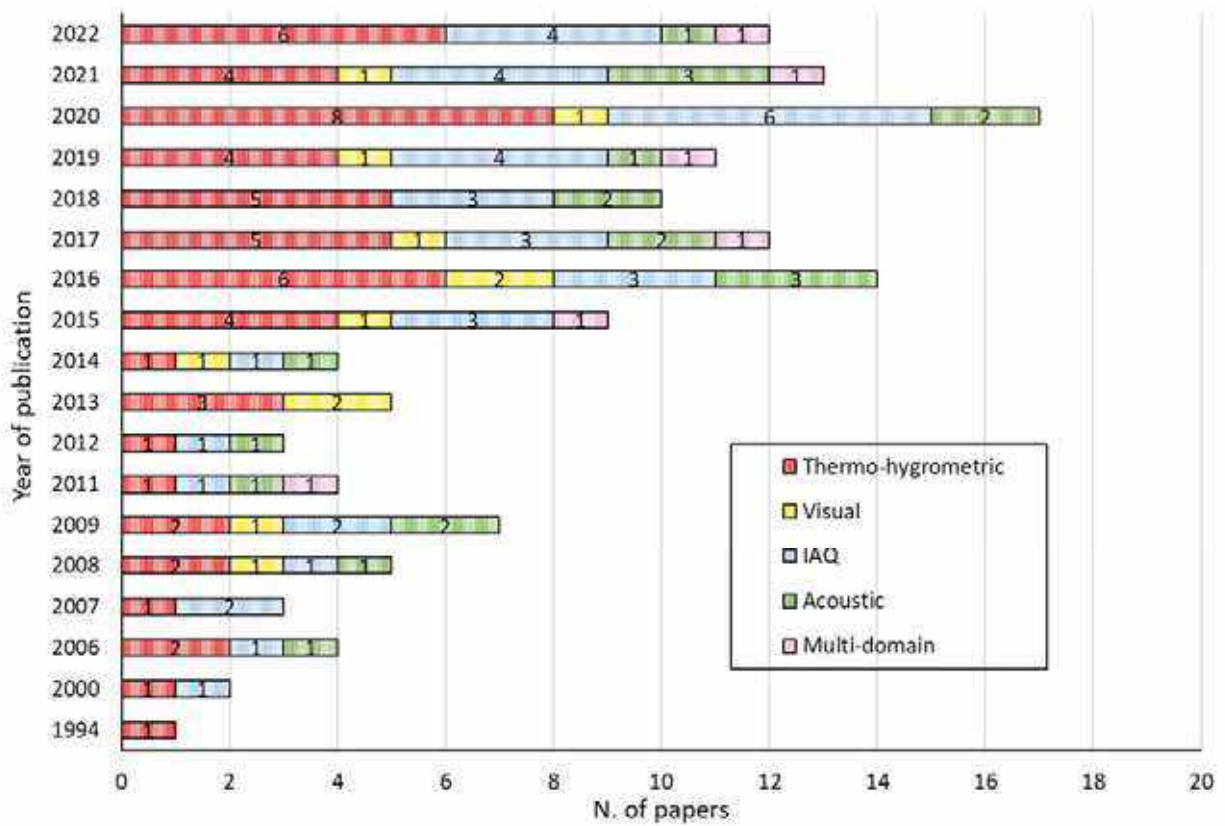


Figure 57: Association between publication year and comfort domain treated

Table 1: Number of articles per type of environment considered

Type of environment	Number of papers
Residential	18
Educational	12
Healthcare	1
Working	14
Industrial	1
Amusement	1
Non-residential (unspecified)	3
Inapplicable (various, unspecified, ...)	13

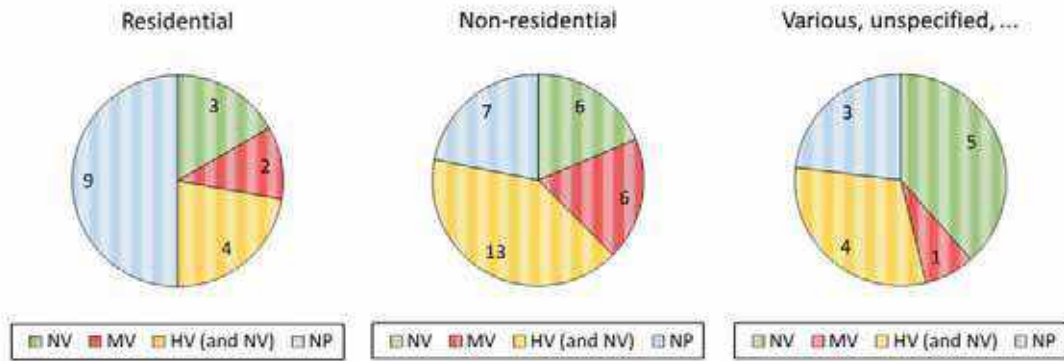


Figure 58: Number of papers per type of ventilation recommended, divided by type of environment. NV = natural ventilation; MV = mechanical ventilation; HV = hybrid ventilation; NP = no clear preference

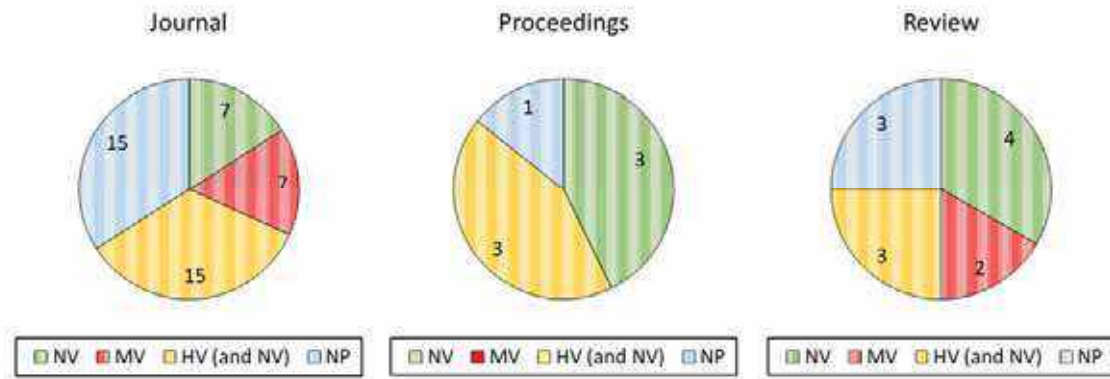


Figure 59: Number of articles per type of ventilation recommended, divided by type of document. NV = natural ventilation; MV = mechanical ventilation; HV = hybrid ventilation; NP = no clear preference

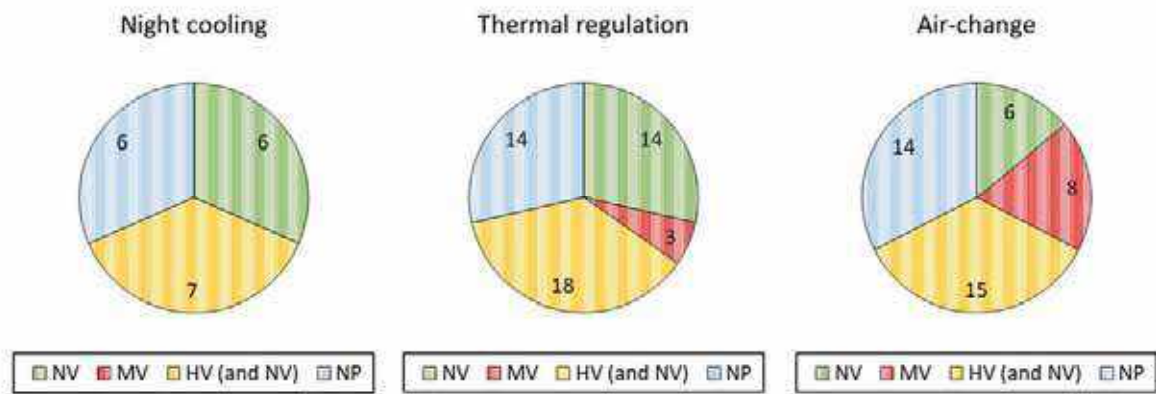


Figure 60: Number of articles per type of ventilation recommended, divided by aim of ventilation considered. NV = natural ventilation; MV = mechanical ventilation; HV = hybrid ventilation; NP = no clear preference

#### 5.4. Main outcomes of literature analysis

Main outcomes are summarized and listed here below:

1. Not many studies comparing NV and MV in terms of indoor comfort and well-being were found. Especially, literature lacks of comparison of NV and MV in some non-residential facilities, such as healthcare ones.
2. The number of papers on the topic is growing in time. A sudden increase is present in 2020.
3. Most papers deal with thermo-hygrometric or IAQ comfort. Other domains are named marginally in less recent papers, and more frequent in the most recent years as part of a multi-domain framework.
4. In most cases, papers dealing with visual or acoustic comfort, or dealing with multi-domain, treat them only marginally (e.g., highlighting that their connections with other domains are important in future research).
5. The necessity to study the lighting and the noise domains connected with NV is pointed out by some papers.
6. When there is a preference of occupants for NV, this is mainly due to control, air movement and access to the outside.
7. Main disadvantages of NV are dealing with the ability to guarantee IAQ and desired comfort conditions. In this sense, main obstacles in using NV are outside pollution, outside noise and outside temperature (too high or too low). Climate change will further limit the NV useful time in warmer regions, but will expand it in colder regions.
8. Nevertheless, there is the need to further deepen the effects of pleasant sounds from outside on indoor comfort. This aspect is not taken into account in standards by now.
9. In many cases, the ability to precisely control the environmental conditions by MV was not perceived by occupants.
10. Another limit of NV is that it might be too dependent on people behavior (in opening windows).
11. Main disadvantages of MV are dealing with the energy consumed, the lack of control and plant's noise. MV systems needs to be properly design in order to minimize these problems.
12. Some papers argue that, if using solutions like heat recovery, MV can save energy with respect to NV.
13. In general, indoor environment and energy consumed are strongly influenced by behavior.
14. Different solutions give different impacts, which can be observed on different indicators of IAQ (CO<sub>2</sub>, PM, VOC, ...).



15. Attention to elements such as air-tightness of the facility and buildings' materials emissions should also be paid, when designing the ventilation system.
16. Some architectural characteristics like building orientation, position, size of openings, façades, etc., are very important in the design of NV. These elements need to be carefully designed. In this sense, the use of CFD is used or encouraged by many studies.
17. NV and daylight do not compete, but can benefit from similar architectural elements.
18. The type of ventilation to be used is dependent on climate (e.g. use of air conditioning in tropical areas, due to high humidity) as well as economic conditions (two papers stressing the dependence on NV of developing countries). Nevertheless, a proper design and the coupling with other techniques can optimize comfort and energy consumption.
19. HV can be a proper solution to save energy and allow control, using backup MV solutions when proper conditions cannot be maintained by NV alone. Moreover, it permits to use NV when season or time of the day allow it. For these reasons, most studies recommend HV in order to maximize energy efficiency guaranteeing comfort and IAQ in all seasons.
20. The share of papers suggesting NV alone was growing until 2020, mostly because of energy efficiency reasons. After COVID-19 pandemic, this proportion seems to have decreased. In fact, the importance of MV or HV for health and air purification reasons are often emphasized later, especially in some non-residential environments. The need to move the ventilation design from a comfort-based to a health-based approach is sometimes highlighted.
21. MV alone is mostly recommended in non-residential environments. In both residential and non-residential, a considerable share of papers recommend the use of HV. It is also interesting to notice that in papers speaking about ventilation with a general point of view (not referring to a specific environment), NV and HV are mostly recommended.
22. Some papers highlight the necessity of changing standards and guidelines in order to decrease energy consumption, improve comfort and encourage NV. For instance, a classification of environments based on windows' control level instead than considering only air conditioning presence, was proposed by one paper.
23. Not many studies dealing with night cooling were found. The necessary of further studies in the field was highlighted also by some articles. Moreover, when considered, night cooling was mostly treated marginally and within some general considerations.
24. No clear trends in the type of ventilation suggested were observed categorizing the papers per type of document or per aim of ventilation considered. The only remarkable observation is that no conference papers recommending MV only were found.

## 6. References

- [1] T. Sterk, 'Thoughts for Gen X— Speculating about the Rise of Continuous Measurement in Architecture' in Sterk, Loveridge, Pancoast "Building A Better Tomorrow", in *Proceedings of the 29th annual conference of the Association of Computer Aided Design in Architecture*, 2009, vol. Sterk, Loveridge, Pancoast 'Building A Better Tomorrow'.
- [2] N. Negroponte, *Soft Architecture Machines*. Cambridge: MA: MIT Press, 1975.
- [3] L. Bullivant, *4dspace: Interactive Architecture*. London: AD/John Wiley & Sons, 2005.
- [4] L. Bullivant, *4dsocial: Interactive Design Environments*. London: AD/John Wiley & Sons, 2007.
- [5] L. Bullivant, *Responsive Environments: architecture, art and design (V&A Contemporary)*. London: Victoria and Albert Museum, 2006.
- [6] P. Beesley, S. Hirosue, J. Ruxton, M. Trankle, and C. Turner, *Responsive Architectures: Subtle Technologies*. Riverside Architectural Press, 2006.
- [7] 'Designing for typologies: 15 examples of climate responsive buildings around the world', *Rethinking The Future*. <https://www.re-thinkingthefuture.com/designing-for-typologies/> (accessed May 19, 2022).

- [8] M. Hu, 'Net-positive Building and Alternative Energy in an Institutional Environment', in *ACEEE Summer Study on Energy Efficiency in Buildings*, 2016, pp. 10–2. [Online]. Available: [https://www.aceee.org/files/proceedings/2016/data/papers/10\\_80.pdf](https://www.aceee.org/files/proceedings/2016/data/papers/10_80.pdf)
- [9] A. Magrini, G. Lentini, S. Cuman, A. Bodrato, and L. Marengo, 'From nearly zero energy buildings (NZEB) to positive energy buildings (PEB): The next challenge - The most recent European trends with some notes on the energy analysis of a forerunner PEB example', *Developments in the Built Environment*, vol. 3, p. 100019, Aug. 2020, doi: 10.1016/j.dibe.2020.100019.
- [10] 'Rethinking IEQ Standards for a Warming Post-COVID World - Are standards promoting air conditioning and marginalising natural ventilation?', *Buildings&Cities*, Feb. 08, 2022. <https://www.buildingsandcities.org/insights/commentaries/rethinking-ieq-standards.html> (accessed May 19, 2022).
- [11] '2226 Lustenau Lustenau, Austria', 2226. <https://www.2226.eu/en/implementation/projekte-details/2226-lustenau-1/> (accessed May 19, 2022).
- [12] 'Eco Boulevard in Vallecas / Ecosistema Urbano', *ArchDaily*. <https://www.archdaily.com/6303/eco-boulevard-in-vallecas-ecosistema-urbano> (accessed May 19, 2022).
- [13] 'Caixa Forum Museum Vertical Garden', *Greenroofs.com*. <https://www.greenroofs.com/projects/caixa-forum-museum-vertical-garden/> (accessed May 19, 2022).
- [14] 'Abu Dhabi Central Market / Foster + Partners', *ArchDaily*. <https://www.archdaily.com/558920/abu-dhabi-central-market-foster-partners> (accessed May 19, 2022).
- [15] H. Hinton, '5 Net Zero Energy Building Examples Worth Emulating', *gb&d Magazine*. <https://gbdmagazine.com/net-zero-energy-building-examples/> (accessed May 10, 2022).
- [16] '2226 / Baumschlager Eberle Architekten', *ArchDaily*. <https://www.archdaily.com/451653/2226-be-baumschlager-eberle> (accessed May 19, 2022).
- [17] M. Krarti, 'Integrated Design and Retrofit of Buildings', in *Optimal Design and Retrofit of Energy Efficient Buildings, Communities, and Urban Centers*, Elsevier, 2018, pp. 313–384. doi: 10.1016/B978-0-12-849869-9.00006-5.
- [18] R. J. de Dear and G. S. Brager, 'Thermal comfort in naturally ventilated buildings: revisions to ASHRAE Standard 55', *Energy and Buildings*, vol. 34, no. 6, pp. 549–561, Jul. 2002, doi: 10.1016/S0378-7788(02)00005-1.
- [19] ANSI/ASHRAE, *Standard 55: 2017, Thermal Environmental Conditions for Human Occupancy*. Atlanta: ASHRAE, 2017.
- [20] P. O. Fanger, *Thermal Comfort. Analysis and Applications in Environmental Engineering*. Copenhagen, Denmark: Danish Technical Press, 1970.
- [21] O. Seppänen and W. J. Fisk, 'Association of ventilation system type with SBS symptoms in office workers: **SBS symptoms in office workers**', *Indoor Air*, vol. 12, no. 2, pp. 98–112, Jun. 2002, doi: 10.1034/j.1600-0668.2002.01111.x.
- [22] J. L. Boyer, M. Jalayerian, A. Silverstein, and M. T. Araji, 'Systems Integration for Cost Effective Carbon Neutral Buildings: A Masdar Headquarters Case Study', in *ASME 2010 4th International Conference on Energy Sustainability, Volume 1*, Phoenix, Arizona, USA, Jan. 2010, pp. 1029–1039. doi: 10.1115/ES2010-90335.
- [23] K. Elgendy, 'Abu Dhabi's Masdar Headquarters: The First Positive-Energy Building in the Middle East'. <https://www.carboun.com/sustainable-design/masdar-headquarters-the-first-positive-energy-building-in-the-middle-east/> (accessed May 19, 2022).
- [24] A. Bhatia, 'HVAC – Natural Ventilation Principles'. CED engineering.com. Accessed: May 23, 2022. [Online]. Available: <https://www.cedengineering.com/userfiles/HVAC%20-%20Natural%20Ventilation%20Principles%20R1.pdf>
- [25] U. Passe and F. Battaglia, *Designing spaces for natural ventilation - An architect's guide*. Routledge.
- [26] H. Zhang *et al.*, 'A critical review of combined natural ventilation techniques in sustainable buildings', *Renewable and Sustainable Energy Reviews*, vol. 141, p. 110795, May 2021, doi: 10.1016/j.rser.2021.110795.
- [27] F. Jomehzadeh *et al.*, 'A review on windcatcher for passive cooling and natural ventilation in buildings, Part 1: Indoor air quality and thermal comfort assessment', *Renewable and Sustainable Energy Reviews*, vol. 70, pp. 736–756, Apr. 2017, doi: 10.1016/j.rser.2016.11.254.

- [28] D. Etheridge, *Natural ventilation of buildings: theory, measurement and design*. John Wiley & Sons, 2011.
- [29] S. Alvarez, E. Dascalaki, G. Guarracino, E. Maldonado, S. Sciuto, and L. Vandaele, *Natural ventilation in buildings. A design handbook*. James & James, 1998.
- [30] M. Grosso, *Il raffrescamento passivo degli edifici in zone a clima temperato*, Second. Maggioli Editore, 2008.
- [31] 'Darco Chimney Cowsls'. <https://www.aluroofing.co.uk/darco-chimney-cowls> (accessed May 23, 2022).
- [32] 'Stack ventilation', *2030 Palette*. <http://www.2030palette.org/stack-ventilation/>
- [33] N. Thomas, 'Energy', in *Field Guide to Appropriate Technology*, Elsevier, 2003, pp. 157–275. doi: 10.1016/B978-012335185-2/50046-2.
- [34] 'Il muro di Trombe-Michel', *Young Architects*. <https://youngarchitectspalermo.altervista.org/articoli-di-architettura/il-muro-di-trombe-michel/> (accessed May 24, 2022).
- [35] A. Bozikovic, 'Case Method: McEwen Graduate Study & Research Building, York University, Toronto, Ontario', *Canadian Architect*. <https://www.canadianarchitect.com/case-method-mcewen-graduate-study-research-building-york-university-toronto-ontario/> (accessed May 24, 2022).
- [36] G. Quesada, D. Rousse, Y. Dutil, M. Badache, and S. Hallé, 'A comprehensive review of solar facades. Opaque solar facades', *Renewable and Sustainable Energy Reviews*, vol. 16, no. 5, pp. 2820–2832, Jun. 2012, doi: 10.1016/j.rser.2012.01.078.
- [37] J. Atkinson, Y. Chartier, C. L. Pessoa-Silva, Y. Li, and W.-H. Seto, *Natural Ventilation for Infection Control in Health-Care Settings*. Geneva: World Health Organization, 2009.
- [38] J. A. Orosa and A. C. Oliveira, *Passive methods as a solution for improving indoor environments*. 2012.
- [39] R. de Dear, 'The Theory of Thermal Comfort in Naturally Ventilated Indoor Environments - "The Pleasure Principle"', *INTERNATIONAL JOURNAL OF VENTILATION*, vol. 8, no. 3, pp. 243–250, Dec. 2009.
- [40] P. Blondeau, M. Spérandio, and F. Allard, 'Night ventilation for building cooling in summer', *Solar Energy*, vol. 61, no. 5, pp. 327–335, Nov. 1997, doi: 10.1016/S0038-092X(97)00076-5.
- [41] S. Erba, A. Sangalli, and L. Pagliano, 'Present and future potential of natural night ventilation in nZEBs', *IOP Conf. Ser.: Earth Environ. Sci.*, vol. 296, no. 1, p. 012041, Jul. 2019, doi: 10.1088/1755-1315/296/1/012041.
- [42] B. Givoni, 'Effectiveness of mass and night ventilation in lowering the indoor daytime temperatures. Part I: 1993 experimental periods', *Energy and Buildings*, vol. 28, no. 1, pp. 25–32, Aug. 1998, doi: 10.1016/S0378-7788(97)00056-X.
- [43] E. Shaviv, A. Yezioro, and I. G. Capeluto, 'Thermal mass and night ventilation as passive cooling design strategy', *Renewable Energy*, vol. 24, no. 3–4, pp. 445–452, Nov. 2001, doi: 10.1016/S0960-1481(01)00027-1.
- [44] CIBSE, 'TM40: Health and wellbeing in building services'. Chartered Institution of Building Services Engineers (CIBSE), 2019. [Online]. Available: <https://www.cibse.org/Knowledge/CIBSETM/TM40-2019-Health-Issues-and-Wellbeing-in-Building-Services#Exec%20summary> (<https://www.cibse.org/Knowledge/CIBSE-TM/TM40-2019-Health-Issues-and-Wellbeing-in-BuildingServices#Exec%20summary>)
- [45] A. Ronold, 'Chapter 17 - Ventilation', in *Computational Wind Engineering 1*, 1993.
- [46] UNI 10339 - *Air-conditioning systems for thermal comfort in buildings - General, classification and requirements - Offer, order and supply specifications*.
- [47] P. Wolkoff, K. Azuma, and P. Carrer, 'Health, work performance, and risk of infection in office-like environments: The role of indoor temperature, air humidity, and ventilation', *International Journal of Hygiene and Environmental Health*, vol. 233, p. 113709, Apr. 2021, doi: 10.1016/j.ijheh.2021.113709.
- [48] S. Torresin *et al.*, 'Indoor soundscapes at home during the COVID-19 lockdown in London – Part I: Associations between the perception of the acoustic environment, occupant's activity and well-being', *Applied Acoustics*, vol. 183, p. 108305, Dec. 2021, doi: 10.1016/j.apacoust.2021.108305.
- [49] S. Torresin *et al.*, 'Indoor soundscapes at home during the COVID-19 lockdown in London – Part II: A structural equation model for comfort, content, and well-being', *Applied Acoustics*, vol. 185, p. 108379, Jan. 2022, doi: 10.1016/j.apacoust.2021.108379.
- [50] V. Olgyay, *Design with Climate: Bioclimatic Approach to Architectural Regionalism*. 1963.

- [51] C. O. Ryan, W. D. Browning, J. O. Clancy, S. L. Andrews, and N. B. Kallianpurkar, 'BIOPHILIC DESIGN PATTERNS: Emerging Nature-Based Parameters for Health and Well-Being in the Built Environment', *ArchNet-IJAR*, vol. 8, no. 2, p. 62, Jul. 2014, doi: 10.26687/archnet-ijar.v8i2.436.
- [52] R. S. Ulrich, 'View Through a Window May Influence Recovery from Surgery', *Science*, vol. 224, no. 4647, pp. 420–421, Apr. 1984, doi: 10.1126/science.6143402.
- [53] N. Hähn, E. Essah, and T. Blanusa, 'Biophilic design and office planting: a case study of effects on perceived health, well-being and performance metrics in the workplace', *Intelligent Buildings International*, vol. 13, no. 4, pp. 241–260, Oct. 2021, doi: 10.1080/17508975.2020.1732859.
- [54] S. Altomonte *et al.*, 'Ten questions concerning well-being in the built environment', *Building and Environment*, pp. 106949–106949, 2020, doi: 10.1016/j.buildenv.2020.106949.
- [55] A. Abdul Hamid, D. Johansson, and H. Bagge, 'Ventilation measures for heritage office buildings in temperate climate for improvement of energy performance and IEQ', *Energy and Buildings*, vol. 211, p. 109822, Mar. 2020, doi: 10.1016/j.enbuild.2020.109822.
- [56] S. Diaz de Garayo, A. Martínez, and D. Astrain, 'Optimal combination of an air-to-air thermoelectric heat pump with a heat recovery system to HVAC a passive house dwelling', *Applied Energy*, vol. 309, p. 118443, Mar. 2022, doi: 10.1016/j.apenergy.2021.118443.
- [57] R. M. Lazzarin and A. Gasparella, 'Technical and economical analysis of heat recovery in building ventilation systems', *Applied Thermal Engineering*, vol. 18, no. 1–2, pp. 47–67, Jan. 1998, doi: 10.1016/S1359-4311(97)00013-6.
- [58] 'Heat recovery: Overview', *airtecnics*. <https://www.airtecnics.com/technology/heat-recovery-overview>
- [59] A. Mardiana-Idayu and S. B. Riffat, 'Review on heat recovery technologies for building applications', *Renewable and Sustainable Energy Reviews*, vol. 16, no. 2, pp. 1241–1255, Feb. 2012, doi: 10.1016/j.rser.2011.09.026.
- [60] T. R. Nielsen, J. Rose, and J. Kragh, 'Dynamic model of counter flow air to air heat exchanger for comfort ventilation with condensation and frost formation', *Applied Thermal Engineering*, p. 7, 2009.
- [61] A. Vali, C. J. Simonson, R. W. Besant, and G. Mahmood, 'Numerical model and effectiveness correlations for a run-around heat recovery system with combined counter and cross flow exchangers', *International Journal of Heat and Mass Transfer*, p. 14, 2009.
- [62] M. Fehrm, W. Reiners, and M. Ungemach, 'Exhaust air heat recovery in buildings', *International Journal of Refrigeration*, vol. 25, no. 4, pp. 439–449, Jun. 2002, doi: 10.1016/S0140-7007(01)00035-4.
- [63] 'Climate Change 2022 - Mitigation of Climate Change. Working Group III contribution to the Sixth Assessment Report (AR6) of the Intergovernmental Panel on Climate Change', Intergovernmental Panel on Climate Change (IPCC), 2022. Accessed: May 25, 2022. [Online]. Available: [https://report.ipcc.ch/ar6wg3/pdf/IPCC\\_AR6\\_WGIII\\_FinalDraft\\_FullReport.pdf](https://report.ipcc.ch/ar6wg3/pdf/IPCC_AR6_WGIII_FinalDraft_FullReport.pdf)
- [64] J. Rogelj, D. Shindell, K. Jiang, and et al., 'Chapter 2 - Mitigation Pathways Compatible with 1.5°C in the Context of Sustainable Development', International Panel of Climate Change (IPCC), 2018. Accessed: May 25, 2022. [Online]. Available: [https://www.ipcc.ch/site/assets/uploads/sites/2/2019/05/SR15\\_Chapter2\\_High\\_Res.pdf](https://www.ipcc.ch/site/assets/uploads/sites/2/2019/05/SR15_Chapter2_High_Res.pdf)
- [65] 'Heat Pumps - Analysis'. International Energy Agency (accessed May 25, 2022).
- [66] 'COP (Coefficient of Performance)', *Grundfos*. <https://www.grundfos.com/solutions/learn/research-and-insights/coefficient-of-system-performance> (accessed May 25, 2022).
- [67] 'Heat Pump Systems', *Energy.gov*. <https://www.energy.gov/energysaver/heat-pump-systems#:~:text=There%20are%20three%20main%20types,concentrate%20it%20for%20use%20inside>. (accessed May 25, 2022).
- [68] 'In-depth guide to heat pumps', *energy saving trust*. <https://energysavingtrust.org.uk/advice/in-depth-guide-to-heat-pumps/> (accessed May 25, 2022).
- [69] 'Domestic Heat Pumps - A best Practice Guide', MCS. Accessed: May 25, 2022. [Online]. Available: <https://mcs-certified.com/wp-content/uploads/2020/07/Heat-Pump-Guide.pdf>
- [70] 'Caratteristiche della ventilazione meccanica controllata', *Casa Pratica*.
- [71] A. Cazorla Marín, 'MODELLING AND EXPERIMENTAL VALIDATION OF AN INNOVATIVE COAXIAL HELICAL BOREHOLE HEAT EXCHANGER FOR A DUAL SOURCE HEAT PUMP SYSTEM', Universitat Politècnica de València, Valencia (Spain), 2019. doi: 10.4995/Thesis/10251/125696.



- [72] ASHRAE, *ASHRAE Handbook - Fundamentals*. American Society of Heating, Refrigerating and Air-Conditioning Engineers (ASHRAE), 2021.
- [73] HRAI, *Residential Mechanical Ventilation - National (SAR-R4)*. The Heating, Refrigeration and Air Conditioning Institute of Canada (HRAI), 2010. [Online]. Available: <https://www.hrai.ca/technical-manual/residential-mechanical-ventilation---national--sar-r4->
- [74] R. Edwards, *Handbook of Domestic Ventilation*. London: Taylor & Francis, 2005. [Online]. Available: <https://doi.org/10.4324/9780080454580>
- [75] P. H. Raymer, *Residential Ventilation Handbook*, 2nd ed. Home Ventilation Management, 2017.
- [76] ASHRAE, 'Applied Heat Pump and Heat Recovery System', *ASHRAE*. <https://www.ashrae.org/advertising/handbook-advertising/systems/applied-heat-pump-and-heat-recovery-systems> (accessed May 25, 2022).
- [77] E. H. Mathews, A. G. Shuttleworth, and P. G. Rousseau, 'Validation and further development of a novel thermal analysis method', *Building and Environment*, vol. 29, no. 2, pp. 207–215, Jan. 1994, doi: 10.1016/0360-1323(94)90071-X.
- [78] G. Brager and L. Baker, 'Occupant satisfaction in mixed-mode buildings', *Building Research & Information*, vol. 37, no. 4, pp. 369–380, Aug. 2009, doi: 10.1080/09613210902899785.
- [79] G. Carrilho da Graça and P. Linden, 'Ten questions about natural ventilation of non-domestic buildings', *Building and Environment*, vol. 107, pp. 263–273, Oct. 2016, doi: 10.1016/j.buildenv.2016.08.007.
- [80] J. C. Salcido, A. A. Raheem, and Raja. R. A. Issa, 'From simulation to monitoring: Evaluating the potential of mixed-mode ventilation (MMV) systems for integrating natural ventilation in office buildings through a comprehensive literature review', *Energy and Buildings*, vol. 127, pp. 1008–1018, Sep. 2016, doi: 10.1016/j.enbuild.2016.06.054.
- [81] X. Meng, Y. Wang, X. Xing, and Y. Xu, 'Experimental study on the performance of hybrid buoyancy-driven natural ventilation with a mechanical exhaust system in an industrial building', *Energy and Buildings*, vol. 208, p. 109674, Feb. 2020, doi: 10.1016/j.enbuild.2019.109674.
- [82] B. Raji, M. J. Tenpierik, R. Bokel, and A. van den Dobbelen, 'Natural summer ventilation strategies for energy-saving in high-rise buildings: a case study in the Netherlands', *International Journal of Ventilation*, vol. 19, no. 1, pp. 25–48, Jan. 2020, doi: 10.1080/14733315.2018.1524210.
- [83] J. Chen, G. Augenbroe, and X. Song, 'Model Predictive Control Strategy for Hybrid Ventilation Building Operation', in *Construction Research Congress 2018*, New Orleans, Louisiana, Mar. 2018, pp. 390–399. doi: 10.1061/9780784481301.039.
- [84] *Principles of Hybrid Ventilation*. Aalborg (Denmark): Aalborg University, Hybrid Ventilation Centre. [Online]. Available: [https://iea-ebc.org/Data/publications/EBC\\_Annex\\_35\\_Principles\\_of\\_H\\_V.pdf](https://iea-ebc.org/Data/publications/EBC_Annex_35_Principles_of_H_V.pdf)
- [85] *Annex 35 - Hybrid Ventilation in New and Retrofitted Office Buildings*. Hybrid Ventilation in New and Retrofitted Office Buildings. [Online]. Available: [https://www.iea-ebc.org/Data/publications/EBC\\_Annex\\_35\\_tsr.pdf](https://www.iea-ebc.org/Data/publications/EBC_Annex_35_tsr.pdf)
- [86] E. Newton, 'Here's How to Design Climate Responsive Homes', *Construction21 International*, 2021. <https://www.construction21.org/articles/h/here-s-how-to-design-climate-responsive-homes.html> (accessed May 26, 2022).
- [87] 'Engineering a net positive energy building', *Surbana Jurong*, 2020. <https://surbanajurong.com/resources/news/engineering-a-net-positive-energy-building/> (accessed May 26, 2022).
- [88] S. Bodach, W. Lang, and J. Hamhaber, 'Climate responsive building design strategies of vernacular architecture in Nepal', *Energy and Buildings*, vol. 81, pp. 227–242, Oct. 2014, doi: 10.1016/j.enbuild.2014.06.022.
- [89] *UNI EN 15251:2007. Indoor environmental input parameters for design and assessment of energy performance of buildings addressing indoor air quality, thermal environment, lighting and acoustics*. 2007.
- [90] *UNI EN ISO 16798-1:2019 - Energy performance of buildings - Part 1: Indoor environmental input parameters for design and assessment of energy performance of buildings addressing indoor air quality, thermal environment, lighting and acoustics*.



- [91] B. Chenari, J. Dias Carrilho, and M. Gameiro da Silva, 'Towards sustainable, energy-efficient and healthy ventilation strategies in buildings: A review', *Renewable and Sustainable Energy Reviews*, vol. 59, pp. 1426–1447, Jun. 2016, doi: 10.1016/j.rser.2016.01.074.
- [92] B. W. Olesen, P. Bluyssen, and C.-A. Roulet, *Ventilation and indoor environmental quality*, vol. Awbi HB (ed.) Ventilation Systems-Design and Performance. London: Taylor & Francis, 2008.
- [93] ASHRAE, 'COVID-19 Guidance for Multifamily Building Owners/Managers'. American Society of Heating, Refrigerating and Air-Conditioning Engineers (ASHRAE), 2020. [Online]. Available: [https://www.ashrae.org/file%20library/technical%20resources/covid-19/covid-19-guidance-for-multifamily-building-owners\\_managers.pdf](https://www.ashrae.org/file%20library/technical%20resources/covid-19/covid-19-guidance-for-multifamily-building-owners_managers.pdf)
- [94] ASHRAE, 'Residential COVID-19 Guidance'. American Society of Heating, Refrigerating and Air-Conditioning Engineers (ASHRAE), 2021. [Online]. Available: <https://www.ashrae.org/file%20library/technical%20resources/covid-19/ashrae-covid-19-residential-guidance.pdf>
- [95] ASHRAE, 'Residences FAQ'. American Society of Heating, Refrigerating and Air-Conditioning Engineers (ASHRAE), 2021. [Online]. Available: <https://www.ashrae.org/technical-resources/residences-faq>
- [96] CIBSE, 'COVID-19: Ventilation. Version 5'. Chartered Institution of Building Services Engineers (CIBSE), 2021. [Online]. Available: <https://www.cibse.org/emerging-from-lockdown#1>
- [97] REHVA, 'COVID-19 Guidance. Version 4.1'. Federation of European Heating, Ventilation and Air Conditioning Associations (REHVA), 2021. [Online]. Available: <https://www.rehva.eu/activities/covid-19-guidance/rehva-covid-19-guidance>
- [98] C. A. Short, R. Yao, G. Luo, and B. Li, 'Exploiting a Hybrid Environmental Design Strategy in the Continental Climate of Beijing', *International Journal of Ventilation*, vol. 11, no. 2, pp. 105–130, Sep. 2012, doi: 10.1080/14733315.2012.11683975.
- [99] A. Rysanek, R. Nuttall, and J. McCarty, 'Forecasting the impact of climate change on thermal comfort using a weighted ensemble of supervised learning models', *Building and Environment*, vol. 190, p. 107522, Mar. 2021, doi: 10.1016/j.buildenv.2020.107522.
- [100] 'Systematic Reviews & Other Review Types', *University Libraries*. <https://guides.temple.edu/c.php?g=78618&p=4178713#:~:text=A%20systematic%20review%20is%20defined,The%20methods%20used%20must%20be> (accessed Apr. 04, 2022).
- [101] 'Web of Science'. Clarivate. Accessed: Apr. 27, 2022. [Online]. Available: <https://clarivate.com/webofsciencegroup/solutions/web-of-science/>
- [102] M. Hanc, C. McAndrew, and M. Ucci, 'Conceptual approaches to wellbeing in buildings: a scoping review', *null*, vol. 47, no. 6, pp. 767–783, Aug. 2019, doi: 10.1080/09613218.2018.1513695.
- [103] V. Butala and S. Muhič, 'Perception of Air Quality and the Thermal Environment in Offices', *Indoor and Built Environment*, vol. 16, no. 4, pp. 302–310, Aug. 2007, doi: 10.1177/1420326X06079886.
- [104] A. M. Omer, 'Renewable building energy systems and passive human comfort solutions', *Renewable and Sustainable Energy Reviews*, vol. 12, no. 6, pp. 1562–1587, Aug. 2008, doi: 10.1016/j.rser.2006.07.010.
- [105] G. M. Stavrakakis, M. K. Koukou, M. Gr. Vrachopoulos, and N. C. Markatos, 'Natural cross-ventilation in buildings: Building-scale experiments, numerical simulation and thermal comfort evaluation', *Energy and Buildings*, vol. 40, no. 9, pp. 1666–1681, Jan. 2008, doi: 10.1016/j.enbuild.2008.02.022.
- [106] M. Azarbayjani, 'Climatic based consideration of double skin facade system: Natural ventilation performance of a case study with double skin facade in mediterranean climate', presented at the 13th Conference of International Building Performance Simulation Association, Chambéry (France), Aug. 2013. doi: [https://www.aivc.org/sites/default/files/p\\_2181.pdf](https://www.aivc.org/sites/default/files/p_2181.pdf).
- [107] A. Aflaki, N. Mahyuddin, Z. Al-Cheikh Mahmoud, and M. R. Baharum, 'A review on natural ventilation applications through building façade components and ventilation openings in tropical climates', *Energy and Buildings*, vol. 101, pp. 153–162, Aug. 2015, doi: 10.1016/j.enbuild.2015.04.033.
- [108] G. R. Annan and B. A. Nehme, 'Feasibility of Using Natural Ventilation for Indoor Thermal Comfort in Non-Residential Application in Warm Climate', 2016, pp. 123–129.

- [109] E. Rasheed, H. Byrd, B. Money, J. Mbachu, and T. Egbelakin, 'Why Are Naturally Ventilated Office Spaces Not Popular in New Zealand?', *Sustainability*, vol. 9, no. 6, p. 902, May 2017, doi: 10.3390/su9060902.
- [110] 'About Green Star', *New Zealand Green Building Council (NZGBC)*. <https://www.nzgbc.org.nz/greenstar> (accessed Jun. 01, 2022).
- [111] NZGBC, 'Green Star NZ Technical Manual (vs3.1) 2016'. New Zealand Green Building Council (NZGBC). [Online]. Available: [https://www.nzgbc.org.nz/Category?Action=View&Category\\_id=132](https://www.nzgbc.org.nz/Category?Action=View&Category_id=132)
- [112] A. Mukhtar, M. Z. Yusoff, and K. C. Ng, 'The potential influence of building optimization and passive design strategies on natural ventilation systems in underground buildings: The state of the art', *Tunnelling and Underground Space Technology*, vol. 92, p. 103065, Oct. 2019, doi: 10.1016/j.tust.2019.103065.
- [113] R. Singh, R. L. Sawhney, I. J. Lazarus, and V. V. N. Kishore, 'Recent advancements in earth air tunnel heat exchanger (EATHE) system for indoor thermal comfort application: A review', *Renewable and Sustainable Energy Reviews*, vol. 82, pp. 2162–2185, Feb. 2018, doi: 10.1016/j.rser.2017.08.058.
- [114] S. Maas, J. Da Cruz Antunes, and G. Steffgen, 'Energy efficiency and indoor air quality of seminar rooms in older buildings with and without mechanical ventilation', *Bauphysik*, vol. 41, no. 5, pp. 243–251, Oct. 2019, doi: 10.1002/bapi.201900018.
- [115] N. Izadyar, W. Miller, B. Rismanchi, and V. Garcia-Hansen, 'Impacts of façade openings' geometry on natural ventilation and occupants' perception: A review', *Building and Environment*, vol. 170, p. 106613, Mar. 2020, doi: 10.1016/j.buildenv.2019.106613.
- [116] N. Izadyar, W. Miller, B. Rismanchi, and V. Garcia-Hansen, 'Numerical simulation of single-sided natural ventilation: Impacts of balconies opening and depth scale on indoor environment', *IOP Conf. Ser.: Earth Environ. Sci.*, vol. 463, no. 1, p. 012037, Mar. 2020, doi: 10.1088/1755-1315/463/1/012037.
- [117] N. Izadyar, W. Miller, B. Rismanchi, and V. Garcia-Hansen, 'A numerical investigation of balcony geometry impact on single-sided natural ventilation and thermal comfort', *Building and Environment*, vol. 177, p. 106847, Jun. 2020, doi: 10.1016/j.buildenv.2020.106847.
- [118] C. Yadeta, M. Indraganti, E. Alemayehu, and G. T. Tucho, 'An investigation of human thermal comfort and adaptation in naturally ventilated residential buildin', *Science and Technology for the Built Environment*, p. 21.
- [119] E. J. Mba, C. G. Sam-amobi, and F. O. Okeke, 'An Assessment of Orientation on Effective Natural Ventilation for Thermal Comfort in Primary School Classrooms in Enugu City, Nigeria', *EJSD*, vol. 11, no. 2, p. 114, Jun. 2022, doi: 10.14207/ejsd.2022.v11n2p114.
- [120] G. D. Braham, 'Mechanical Ventilation and Fabric Thermal Storage', *Indoor Built Environ*, p. 9.
- [121] Z. Sultan, 'Estimates of associated outdoor particulate matter health risk and costs reductions from alternative building, ventilation and filtration scenarios', *Science of The Total Environment*, vol. 377, no. 1, pp. 1–11, May 2007, doi: 10.1016/j.scitotenv.2007.01.090.
- [122] A. Khaleghi, K. Bartlett, and M. Hodgson, 'FACTORS AFFECTING VENTILATION, INDOOR-AIR QUALITY AND ACOUSTICAL QUALITY IN "GREEN" AND NON-"GREEN" BUILDINGS: A PILOT STUDY', *Journal of Green Building*, vol. 6, no. 3, pp. 168–180, Jul. 2011, doi: 10.3992/jgb.6.3.168.
- [123] P. Guo, S. Wang, B. Xu, Q. Meng, and Y. Wang, 'Reduced-scale experimental model and numerical investigations to buoyance-driven natural ventilation in a large space building', *Building and Environment*, vol. 145, pp. 24–32, Nov. 2018, doi: 10.1016/j.buildenv.2018.09.019.
- [124] L. Stabile, G. Buonanno, A. Frattolillo, and M. Dell'Isola, 'The effect of the ventilation retrofit in a school on CO<sub>2</sub>, airborne particles, and energy consumptions', *Building and Environment*, vol. 156, pp. 1–11, Jun. 2019, doi: 10.1016/j.buildenv.2019.04.001.
- [125] E. Zender-Świercz, 'Microclimate in Rooms Equipped with Decentralized Façade Ventilation Device', *Atmosphere*, vol. 11, no. 8, p. 800, Jul. 2020, doi: 10.3390/atmos11080800.
- [126] *Ergonomics of the Thermal Environment—Analytical Determination and Interpretation of Thermal Comfort Using Calculation of the PMV and PPD Indices and Local Thermal Comfort Criteria; PN EN 7730*. Warsaw (Poland): Polish Committee for Standardization, 2006.
- [127] I.-C. Mareş *et al.*, 'Research on Best Solution for Improving Indoor Air Quality and Reducing Energy Consumption in a High-Risk Radon Dwelling from Romania', *IJERPH*, vol. 18, no. 23, p. 12482, Nov. 2021, doi: 10.3390/ijerph182312482.

- [128] C. Liao *et al.*, 'A survey of bedroom ventilation types and the subjective sleep quality associated with them in Danish housing', *Science of The Total Environment*, vol. 798, p. 149209, Dec. 2021, doi: 10.1016/j.scitotenv.2021.149209.
- [129] E. Ding, D. Zhang, and P. M. Bluyssen, 'Ventilation regimes of school classrooms against airborne transmission of infectious respiratory droplets: A review', *Building and Environment*, vol. 207, p. 108484, Jan. 2022, doi: 10.1016/j.buildenv.2021.108484.
- [130] X. Li, J. Niu, and N. Gao, 'Co-occupant's exposure to exhaled pollutants with two types of personalized ventilation strategies under mixing and displacement ventilation systems', *Indoor Air*, vol. 23, no. 2, pp. 162–171, Apr. 2013, doi: 10.1111/ina.12005.
- [131] M. Perino, 'Short-term airing by natural ventilation - modeling and control strategies', *Indoor Air*, vol. 19, no. 5, pp. 357–380, Oct. 2009, doi: 10.1111/j.1600-0668.2009.00597.x.
- [132] A. Dhalluin and K. Limam, 'Comparison of natural and hybrid ventilation strategies used in classrooms in terms of indoor environmental quality, comfort and energy savings', *Indoor and Built Environment*, vol. 23, no. 4, pp. 527–542, Jul. 2014, doi: 10.1177/1420326X12464077.
- [133] J. F. Montgomery, S. Storey, and K. Bartlett, 'Comparison of the indoor air quality in an office operating with natural or mechanical ventilation using short-term intensive pollutant monitoring', *Indoor and Built Environment*, vol. 24, no. 6, pp. 777–787, Oct. 2015, doi: 10.1177/1420326X14530999.
- [134] R. Daghighi, 'Assessing the thermal comfort and ventilation in Malaysia and the surrounding regions', *Renewable and Sustainable Energy Reviews*, vol. 48, pp. 681–691, Aug. 2015, doi: 10.1016/j.rser.2015.04.017.
- [135] A. Aldawoud, 'Windows design for maximum cross-ventilation in buildings', *Advances in Building Energy Research*, vol. 11, no. 1, pp. 67–86, Jan. 2017, doi: 10.1080/17512549.2016.1138140.
- [136] M. Gil-Baez, Á. Barrios-Padura, M. Molina-Huelva, and R. Chacartegui, 'Natural ventilation systems in 21st-century for near zero energy school buildings', *Energy*, vol. 137, pp. 1186–1200, Oct. 2017, doi: 10.1016/j.energy.2017.05.188.
- [137] F. Barbolini, P. Cappellacci, and L. Guardigli, 'A Design Strategy to Reach nZEB Standards Integrating Energy Efficiency Measures and Passive Energy Use', *Energy Procedia*, vol. 111, pp. 205–214, Mar. 2017, doi: 10.1016/j.egypro.2017.03.022.
- [138] F. Usman and A. R. A. Bakar, 'Thermal Comfort Study Using CFD Analysis in Residential House with Mechanical Ventilation System', in *AWAM International Conference on Civil Engineering*, Cham, Aug. 2019, pp. 1613–1628. [Online]. Available: <https://link.springer.com/content/pdf/10.1007/978-3-030-32816-0.pdf>
- [139] S. Torresin, R. Albatici, F. Aletta, F. Babich, T. Oberman, and J. Kang, 'Associations between indoor soundscapes, building services and window opening behaviour during the COVID-19 lockdown', *Building Services Engineering Research and Technology*, p. 014362442110544, Nov. 2021, doi: 10.1177/01436244211054443.
- [140] S. Torresin, R. Albatici, F. Aletta, F. Babich, T. Oberman, and J. Kang, 'Acoustic Design Criteria in Naturally Ventilated Residential Buildings: New Research Perspectives by Applying the Indoor Soundscape Approach', *APPLIED SCIENCES-BASEL*, vol. 9, no. 24, Dec. 2019, doi: 10.3390/app9245401.
- [141] S. Torresin *et al.*, 'Acoustics for Supportive and Healthy Buildings: Emerging Themes on Indoor Soundscape Research', *Sustainability*, vol. 12, no. 15, p. 6054, Jul. 2020, doi: 10.3390/su12156054.
- [142] A. Monge-Barrio *et al.*, 'Encouraging natural ventilation to improve indoor environmental conditions at schools. Case studies in the north of Spain before and during COVID', *Energy and Buildings*, vol. 254, p. 111567, Jan. 2022, doi: 10.1016/j.enbuild.2021.111567.
- [143] M. H. Elnabawi and E. Saber, 'Reducing carbon footprint and cooling demand in arid climates using an integrated hybrid ventilation and photovoltaic approach', *Environ Dev Sustain*, vol. 24, no. 3, pp. 3396–3418, Mar. 2022, doi: 10.1007/s10668-021-01571-1.
- [144] H. Yin *et al.*, 'Online monitoring of PM<sub>2.5</sub> and CO<sub>2</sub> in residential buildings under different ventilation modes in Xi'an city', *Building and Environment*, vol. 207, p. 108453, Jan. 2022, doi: 10.1016/j.buildenv.2021.108453.
- [145] S. Arata and S. Kawakubo, 'Study on productivity of office workers and power consumption of air conditioners in a mixed-mode ventilation building during springtime', *Building and Environment*, vol. 214, p. 108923, Apr. 2022, doi: 10.1016/j.buildenv.2022.108923.

- [146] T. Kalamees, 'Indoor Climate Conditions and Ventilation Performance in Estonian Lightweight Detached Houses', *Indoor and Built Environment*, vol. 15, no. 6, pp. 555–569, Dec. 2006, doi: 10.1177/1420326X06073076.
- [147] Q. Ouyang, W. Dai, H. Li, and Y. Zhu, 'Study on dynamic characteristics of natural and mechanical wind in built environment using spectral analysis', *Building and Environment*, vol. 41, no. 4, pp. 418–426, Apr. 2006, doi: 10.1016/j.buildenv.2005.02.008.
- [148] R. Razman, H. bin A. Abd, and A. Abdul, 'Study On Thermal Comfort In University Hostel Building Case Study At Universiti Tun Hussein Onn Malaysia (UTHM), Batu Pahat', 2011, vol. 8. [Online]. Available: [https://www.researchgate.net/profile/Abd-Halid-Abdullah/publication/267790423\\_Study\\_On\\_Thermal\\_Comfort\\_In\\_University\\_Hostel\\_Building\\_Case\\_Study\\_At\\_Universiti\\_Tun\\_Hussein\\_Onn\\_Malaysia\\_UTHM\\_Batu\\_Pahat/links/54c3401f0cf256ed5a90e291/Study-On-Thermal-Comfort-In-University-Hostel-Building-Case-Study-At-Universiti-Tun-Hussein-Onn-Malaysia-UTHM-Batu-Pahat.pdf](https://www.researchgate.net/profile/Abd-Halid-Abdullah/publication/267790423_Study_On_Thermal_Comfort_In_University_Hostel_Building_Case_Study_At_Universiti_Tun_Hussein_Onn_Malaysia_UTHM_Batu_Pahat/links/54c3401f0cf256ed5a90e291/Study-On-Thermal-Comfort-In-University-Hostel-Building-Case-Study-At-Universiti-Tun-Hussein-Onn-Malaysia-UTHM-Batu-Pahat.pdf)
- [149] C. W. F. Yu and J. T. Kim, 'Low-Carbon Housings and Indoor Air Quality', *Indoor and Built Environment*, vol. 21, no. 1, pp. 5–15, Feb. 2012, doi: 10.1177/1420326X11431907.
- [150] R. Giridharan, K. J. Lomas, C. A. Short, and A. J. Fair, 'Performance of hospital spaces in summer: A case study of a 'Nucleus'-type hospital in the UK Midlands', *Energy and Buildings*, vol. 66, pp. 315–328, Nov. 2013, doi: 10.1016/j.enbuild.2013.07.001.
- [151] *HTM03-01, Health Technical Memorandum: Specialised ventilation for healthcare premises, Part A-Design and installation*. UK: Department of Health, 2007.
- [152] 'Google Earth Image of Glenfield Hospital', *Google Earth, Inforterra Ltd and Bluesky, USA*, 2012. <http://www.google.com/earth/index.html> (accessed Mar. 20, 2012).
- [153] R. Z. Homod and K. S. M. Sahari, 'Energy savings by smart utilization of mechanical and natural ventilation for hybrid residential building model in passive climate', *Energy and Buildings*, vol. 60, pp. 310–329, May 2013, doi: 10.1016/j.enbuild.2012.10.034.
- [154] S. Natarajan, J. Rodriguez, and M. Vellei, 'A field study of indoor thermal comfort in the subtropical highland climate of Bogota, Colombia', *Journal of Building Engineering*, vol. 4, pp. 237–246, Dec. 2015, doi: 10.1016/j.jobee.2015.10.003.
- [155] ISO, *ISO 7730:2005, Ergonomics of the Thermal Environment – Analytical Determination and Interpretation of Thermal Comfort using Calculation of the PMV and PPD Indices and Local Thermal Comfort Criteria*. International Organization of Standardization (ISO), 2005.
- [156] ASHRAE, *ANSI/ASHRAE Standard 55-2013, Thermal Environmental Conditions for Human Occupancy*. Atlanta, Ga: American Society of Heating, Refrigerating and Air-Conditioning Engineers (ASHRAE), 2013.
- [157] CEN, *EN 15251. Indoor Environmental Input Parameters for Design and Assessment of Energy Performance of Buildings Addressing Indoor Air Quality, Thermal Environment, Lighting and Acoustics*. Brussels, Belgium: Comite'Europe'en de Normalisation (CEN), 2007.
- [158] E. Grigoropoulos, D. Anastaselos, S. Nižetić, and A. M. Papadopoulos, 'Effective ventilation strategies for net zero-energy buildings in Mediterranean climates', *International Journal of Ventilation*, pp. 1–17, Jul. 2016, doi: 10.1080/14733315.2016.1203607.
- [159] E. A. Nardell, 'Indoor environmental control of tuberculosis and other airborne infections', *Indoor Air*, vol. 26, no. 1, pp. 79–87, Feb. 2016, doi: 10.1111/ina.12232.
- [160] Z. Lei, C. Liu, L. Wang, and N. Li, 'Effect of natural ventilation on indoor air quality and thermal comfort in dormitory during winter', *Building and Environment*, vol. 125, pp. 240–247, Nov. 2017, doi: 10.1016/j.buildenv.2017.08.051.
- [161] A. Heebøll, P. Wargocki, and J. Toftum, 'Window and door opening behavior, carbon dioxide concentration, temperature, and energy use during the heating season in classrooms with different ventilation retrofits—ASHRAE RP1624', *Science and Technology for the Built Environment*, vol. 24, no. 6, pp. 626–637, Jul. 2018, doi: 10.1080/23744731.2018.1432938.
- [162] D. Lai, Y. Qi, J. Liu, X. Dai, L. Zhao, and S. Wei, 'Ventilation behavior in residential buildings with mechanical ventilation systems across different climate zones in China', *Building and Environment*, vol. 143, pp. 679–690, Oct. 2018, doi: 10.1016/j.buildenv.2018.08.006.

- [163] Y. Zhao, H. Sun, and D. Tu, 'Effect of mechanical ventilation and natural ventilation on indoor climates in Urumqi residential buildings', *Building and Environment*, vol. 144, pp. 108–118, Oct. 2018, doi: 10.1016/j.buildenv.2018.08.021.
- [164] J. Fernández-Agüera, S. Domínguez-Amarillo, C. Alonso, and F. Martín-Consuegra, 'Thermal comfort and indoor air quality in low-income housing in Spain: The influence of airtightness and occupant behaviour', *Energy and Buildings*, vol. 199, pp. 102–114, Sep. 2019, doi: 10.1016/j.enbuild.2019.06.052.
- [165] V. E. M. Cardoso, P. F. Pereira, N. M. M. Ramos, and R. M. S. F. Almeida, 'The Impacts of Air Leakage Paths and Airtightness Levels on Air Change Rates', *Buildings*, vol. 10, no. 3, p. 55, Mar. 2020, doi: 10.3390/buildings10030055.
- [166] C. Cai, Z. Sun, L. B. Weschler, T. Li, W. Xu, and Y. Zhang, 'Indoor air quality in schools in Beijing: Field tests, problems and recommendations', *Building and Environment*, vol. 205, p. 108179, Nov. 2021, doi: 10.1016/j.buildenv.2021.108179.
- [167] L. Scheuring and B. Weller, 'An investigation of ventilation control strategies for louver windows in different climate zones', *International Journal of Ventilation*, vol. 20, no. 3–4, pp. 226–235, Oct. 2021, doi: 10.1080/14733315.2020.1777018.





CLIMATE POSITIVE CIRCULAR COMMUNITIES

## **ANNEX**

### **9.3.1 Sheets of Destra Adige - Piedicastello district**

**D4.5 DESIGN GUIDELINES OF CLIMATE POSITIVE CIRCULAR COMMUNITY IN TRENTO**

**WP4 SUSTAINABLE BUILDING (RE) DESIGN**



# PARTITIONING OF THE AREA INTO FOUR SUB-AREAS



1. Area 1: ex Italcementi area



2. Area 2: built-up area



3. Aerial view of Destra Adige - Piedicastello district



4. Area 3: two disused road tunnels



5. Area 4: ex Zuffo parking lot

**Source of images:**

1. <https://www.investinitalyrealstate.com/it/property/trento-italcementi-area/> - (accessed Aug. 5, 2022)
2. University of Trento (DICAM)
3. Image from Google Earth - (accessed Aug. 5, 2022)
4. University of Trento (DICAM)
5. University of Trento (DICAM)



# HISTORY OF THE SITE\_A



1. Piedicastello square, 1800 - 1900



2. Piedicastello square, 1954



3. View of Piedicastello, 1914



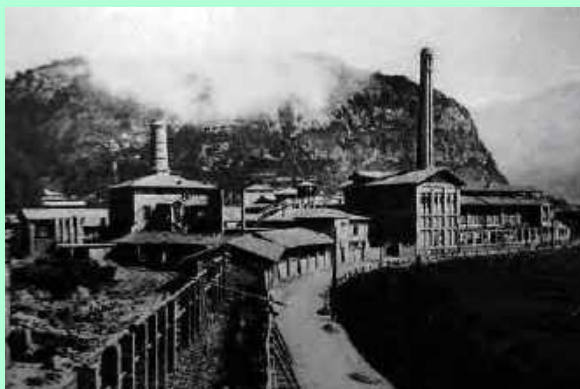
4. Piedicastello square and Brescia street, 1922 - 1935



5. San Lorenzo iron bridge, 1924



6. San Lorenzo concrete bridge, 1960



7. View of the cement factory, 1920



8. View of the metallurgical factory, 1931



### Source of images:

1. <https://www.piedicastello.tn.it/documenti/il-borgo/piedicastello-e-la-citta/> - (accessed Aug. 5, 2022)
2. <https://www.maremagnum.com/cartoline/trento-piedicastello/130097447> - (accessed Aug. 5, 2022)
3. <https://www.maremagnum.com/cartoline/trento-piedicastello/130097438> - (accessed Aug. 5, 2022)
4. <https://www.cultura.trentino.it/Fotografia-Storica/Trento-piazza-di-Piedicastello-e-via-Brescia2> (accessed Aug. 5, 2022)
5. [https://www.maremagnum.com/cartoline/trento-ponte-s-lorenzo-e-sobborgo-di-piedicastello-col-doss / 130097434](https://www.maremagnum.com/cartoline/trento-ponte-s-lorenzo-e-sobborgo-di-piedicastello-col-doss/130097434) - (accessed Aug. 5, 2022)
6. <https://picclick.it/Trento-Tn-Ponte-Di-S-Lorenzo-Con-La-371569464674.html> - (accessed Aug. 5, 2022)
7. <https://www.piedicastello.tn.it/documenti/il-borgo/fabbrica-italcementi/> - (accessed Aug. 5, 2022)
8. <https://www.piedicastello.tn.it/documenti/il-borgo/la-fabbrica-delle-brocche/> - (accessed Aug. 5, 2022)

# HISTORY OF THE SITE\_B



1. View of the Piedicastello primary school, 1930s



2. View of the Piedicastello primary school, 1960s



3. View of the ex Italcementi area, 2012



4. View of the ex Italcementi area, 2015



5. View of Piedicastello, 1914



6. View of Piedicastello, 2000



7. View of the Piedicastello road system, 2005



8. View of the urban-environmental renovation works, 2017

### Source of images:

1. <https://www.piedicastello.tn.it/documenti/il-borgo/la-ex-scuola-elementare/> - (accessed Aug. 5, 2022)
2. <https://www.piedicastello.tn.it/documenti/il-borgo/scuola-materna-di-piedicastello/> - (accessed Aug. 5, 2022)
3. <https://www.flickr.com/photos/29094941@N03/6932851616> - (accessed Aug. 5, 2022)
4. foto di Roberto Bernardinatti in <https://www.investinitalyrealstate.com/it/property/trento-italcementi-area/> - (accessed Aug. 5, 2022)
5. <https://www.maremagnum.com/cartoline/trento-piedicastello/130097438> - (accessed Aug. 5, 2022)
6. <https://www.giornaletrentino.it/cronaca/trento/al-via-i-lavori-sulla-piazza-di-piedicastello-1.662308> - (accessed Aug. 5, 2022)
7. da Piano Guida\_Documentazione storica\_Allegato A.3 <https://www.comune.trento.it/Aree-tematiche/Ambiente-e-territorio/Urbanistica/PRG-Varianti-approvate/PRG-Variante-zona-C5-Area-destra-Adige-ex-Italcementi-a-Trento-2020> - (accessed Aug. 5, 2022)
8. <https://www.dfcostruzioni.it/project/page/3/> - (accessed Aug. 5, 2022)



# DISTRICT SQUARE



1. View of historic buildings



2. View of historic buildings



3. View of the square and Brescia street



4. The fountain in the square



5. View of the church and rectory



6. View of pedestrian area



7. View of the playground



8. Play equipment

**Source of images:**

1. University of Trento (DICAM)
2. University of Trento (DICAM)
3. University of Trento (DICAM)
4. University of Trento (DICAM)
5. University of Trento (DICAM)
6. University of Trento (DICAM)
7. University of Trento (DICAM)
8. University of Trento (DICAM)



# ROUNDBOUT AND ROAD SYSTEM



1. View of new roundabout



2. Traffic circulation and parking in Brescia street



3. Traffic circulation and parking in Papiria street



4. Traffic circulation and parking in Verruca street



5. Traffic circulation and parking in Lungadige Apuleio street

**Source of images:**

1. <https://www.trentotoday.it/cronaca/inaugurazione-piazza-piedicastello-11-novembre.html> - (accessed Aug. 5, 2022)
2. University of Trento (DICAM)
3. University of Trento (DICAM)
4. University of Trento (DICAM)
5. University of Trento (DICAM)

# EX ZUFFO PARKING LOT



1. General view of ex Zuffo parking lot



2. Main entrance



3. Area Zuffo Kiosk bar



4. Bike parking



5. Bike sharing point



**Source of images:**

1. University of Trento (DICAM)
2. University of Trento (DICAM)
3. University of Trento (DICAM)
4. University of Trento (DICAM)
5. University of Trento (DICAM)

# DOSS TRENTO PARK



1. View of Doss Trento



2. Doss Trento Nature Park



3. Pedestrian trail to Doss Trento



4. Alpine Museum



5. Cesare Battisti Mausoleum



6. Cannons in front of the Mausoleum



7. Ruins of an early christian basilica



8. Woods covering the top with many plant species



### Source of images:

1. University of Trento (DICAM)
2. University of Trento (DICAM)
3. University of Trento (DICAM)
4. [https://it.wikipedia.org/wiki/Museo\\_nazionale\\_storico\\_degli\\_Alpini#/media/File:Trento-museo\\_storico\\_truppe\\_alpine.jpg](https://it.wikipedia.org/wiki/Museo_nazionale_storico_degli_Alpini#/media/File:Trento-museo_storico_truppe_alpine.jpg) - (accessed Aug. 5, 2022)
5. University of Trento (DICAM)
6. <http://www.gardatrekking.com/itinerari/trento-val-dadige/doss-trento-cesare-battisti> - (accessed Aug. 5, 2022)
7. <https://www.comune.trento.it/Aree-tematiche/Cultura-e-turismo/Visitare/Natura/Parco-naturale-Doss-Trento> - (accessed Aug. 5, 2022)
8. <https://www.comune.trento.it/Aree-tematiche/Cultura-e-turismo/Visitare/Natura/Parco-naturale-Doss-Trento> - (accessed Aug. 5, 2022)

# PIEDICASTELLO TUNNELS



1. Exterior view of the two disused road tunnels - south side



2. Interior view of the White tunnel



3. Set-up for cultural event in the White tunnel



4. Exterior view of the two disused road tunnels - north side

**Source of images:**

1. University of Trento (DICAM)
2. University of Trento (DICAM)
3. University of Trento (DICAM)
4. University of Trento (DICAM)
5. University of Trento (DICAM)



# BUILT HERITAGE - Historical buildings



1. View of historic buildings



2. Historical buildings



3. Historical buildings



5. Historical buildings



4. Historical buildings



6. Historical buildings



7. Historical buildings

**Source of images:**

1. University of Trento (DICAM)
2. University of Trento (DICAM)
3. University of Trento (DICAM)
4. University of Trento (DICAM)
5. University of Trento (DICAM)
6. University of Trento (DICAM)
7. University of Trento (DICAM)



# BUILT HERITAGE - Workers' housing



1. Gardens



2. Building on the corner of Papiria street and Verrucca street



3. Access with steps to building in Verrucca street



4. Buildings in Papiria street



5. Buildings in Verrucca street



6. Buildings in Papiria street



7. Buildings in Verrucca street

**Source of images:**

1. University of Trento (DICAM)
2. University of Trento (DICAM)
3. University of Trento (DICAM)
4. University of Trento (DICAM)
5. University of Trento (DICAM)
6. University of Trento (DICAM)
7. University of Trento (DICAM)



## BUILT HERITAGE - Social housing in Lungadige Apuleio street



1. Built area in Lungadige Apuleio street



2. View of a group of social housing



3. Detail of a building of social housing



4. Detail of a building of social housing



5. Recently renovated buildings of social housing

**Source of images:**

1. University of Trento (DICAM)
2. University of Trento (DICAM)
3. University of Trento (DICAM)
4. University of Trento (DICAM)
5. University of Trento (DICAM)



## BUILT HERITAGE - Social housing in Doss Trento street



1. View of ITEA social housing



2. 4-storey building



3. 5-storey building



4. Multi-storey apartment blocks



5. 6-storey building



**Source of images:**

1. University of Trento (DICAM)
2. University of Trento (DICAM)
3. University of Trento (DICAM)
4. University of Trento (DICAM)
5. University of Trento (DICAM)

## BUILT HERITAGE - Small residential buildings



1. Building in Papiria street



2. Building in Doss Trento street



3. Details of buildings in Doss Trento street



4. Building in Doss Trento street



5. Building in Brescia street



6. Small construction site of building in Doss Trento street



7. Building in Doss Trento street

**Source of images:**

1. University of Trento (DICAM)
2. University of Trento (DICAM)
3. University of Trento (DICAM)
4. University of Trento (DICAM)
5. University of Trento (DICAM)
6. University of Trento (DICAM)
7. University of Trento (DICAM)



# SERVICES AND COLLECTIVE SPACES



1. Commercial and service activities in Brescia street



2. Commercial and service activities in Brescia street



3. Restaurant on the square



4. Trattoria on the square



5. Portland Theatre in Papiria Street



6. Public kindergarten in Doss Trento street



7. Building street with the multi-purpose room of the district



8. Bruno Social Centre in Lungadige San Nicolò street

**Source of images:**

1. University of Trento (DICAM)
2. University of Trento (DICAM)
3. University of Trento (DICAM)
4. University of Trento (DICAM)
5. University of Trento (DICAM)
6. University of Trento (DICAM)
7. University of Trento (DICAM)
8. University of Trento (DICAM)





CLIMATE POSITIVE CIRCULAR COMMUNITIES

## **ANNEX**

### 9.3.2 Table of Meetings with Stakeholders

**D4.5 DESIGN GUIDELINES OF CLIMATE POSITIVE CIRCULAR COMMUNITY IN TRENTO**

**WP4 SUSTAINABLE BUILDING (RE) DESIGN**

Table\_ Meetings with STAKEHOLDERS\_TRENTO DEMONSTRATION PROJECT\_ ECD of the New Building in Area 4

WHEN	WHO and WHERE	PARTICIPANTS	ITEMS discussed	NOTE
17.05.2022	<b>Municipality of Trento</b> via Alfieri n.6 Trento	<b>EURAC</b> - dott. D. Vettorato  <b>UNITN</b> - prof. A. Frattari  <b>Municipality of Trento</b> - council member E. Facchin (Mobility and Ecological Transition Department) - ing. G. Franzoi (Mobility and Urban Regeneration Department) - ing. S. Fedrizzi (Urban Planning Service)  <b>DOLOMITI ENERGIA</b> - ing. N. Fruet	New Building in Area 4: urban planning constraints and its possible function	
24.06.2022	<b>Citizens of Piedicastello (Trento)</b> sala circoscrizionale in VIA VERRUCA n. 1 - PIEDICASTELLO	<b>Municipality of Trento</b> - council member M. Baggia (Land use planning and private building Department) - council member E. Facchin (Mobility and Ecological Transition Department)  <b>UNITN</b> - prof. R. Albatici  <b>EURAC</b> - dott. D. Vettorato  <b>DOLOMITI ENERGIA</b> - ing. N. Fruet  <b>HABITECH</b> - dott. M. Curci  <b>Circoscrizione Centro Storico Piedicastello</b> - ing. C. Geat (President) - citizens and residents	Presentation of ARV project and Trento demonstration site (contribute of D. Vettorati) An experience of geothermal applied to buildings (contribute of Marcello Pegoretti) Piedicastello towards a CCPC?  Rounde table and discussion	This is the first public meeting with citizens and residents of the Piedicastello district. Title of the meeting “Geothermal and energy renovation of the of Piedicastello district - The European ARV project”. Promotion with flyer, communication via social facebook groups. <a href="https://greendeal-arv.eu/wp-content/uploads/2022/07/Flyer_Piedicastello-meeting.pdf">https://greendeal-arv.eu/wp-content/uploads/2022/07/Flyer_Piedicastello-meeting.pdf</a>

18.07.2022	<b>Municipality of Trento</b> via Alfieri n.6 Trento	<p><b>EURAC</b></p> <ul style="list-style-type: none"> <li>- dott. D. Vettorato</li> </ul> <p><b>UNITN</b></p> <ul style="list-style-type: none"> <li>- prof. R.Albatici, prof. M. Dalprà</li> </ul> <p><b>Municipality of Trento</b></p> <ul style="list-style-type: none"> <li>- ing. G. Franzoi (Mobility and Urban Regeneration Department)</li> <li>- ing. S. Fedrizzi (Urban Planning Service)</li> </ul>	<p>New service building in Area 4 and first hypothesis of location in the parking lot called “ex Zuffo”</p> <p>New layout of the area “ex Zuffo” with reference of the Urban Plan for the Sustainable Mobility (PUMS) of Trento</p> <p>New Building as pilot test for the development and implementation of the PUMS of Trento</p> <p>Possible future expansion of the New Building in Area 4 which could also facilitate the management phase</p> <p>Administrative steps of the authorization process</p>	
20.09.2022	<b>Municipality of Trento</b> Via Brennero 312, Trento	<p><b>EURAC</b></p> <ul style="list-style-type: none"> <li>- dott. D. Vettorato</li> </ul> <p><b>UNITN</b></p> <ul style="list-style-type: none"> <li>- prof. R.Albatici, prof. A. Frattari</li> </ul> <p><b>Municipality of Trento</b></p> <ul style="list-style-type: none"> <li>- ing. G. Franzoi (Mobility and Urban Regeneration Department)</li> <li>- ing. S. Fedrizzi (Urban Planning Service)</li> </ul> <p><b>HABITECH</b></p> <ul style="list-style-type: none"> <li>- dott. M. Curci, ing. A. Fronk</li> </ul> <p><b>ARMALAM</b></p> <ul style="list-style-type: none"> <li>- ing. F. Ferrario</li> </ul>	<p>State of the art of the authorization process for the New Building in Area 4</p> <p>Goals, functional program and vision of the New Building in Area 4</p> <p>Definition of the activities which will take place in each space of the building</p> <p>Functional relationship of the spaces and spatial relationship diagrams</p> <p>Preliminary size of each space and formal and volumetric concept</p> <p>Technical requirements of the spaces and the building system</p>	
September 2022	<b>Users</b> online survey	<p><b>End Users</b></p> <ul style="list-style-type: none"> <li>- citizen of Piedicastello District</li> <li>- residents in the Trentino region</li> <li>- national associations (such as Gruppo Acquisti Ibrido GAI)</li> </ul>	<p>Through a questionnaire opinions of potential end-users were collected to verify the first hypotheses on the functional programme of the New Building in area 4.</p>	<p><a href="https://forms.gle/xwfabSZHqU1VmdPw5">https://forms.gle/xwfabSZHqU1VmdPw5</a></p>



CLIMATE POSITIVE CIRCULAR COMMUNITIES

## **ANNEX**

### 9.3.3 Online survey

**D4.5 DESIGN GUIDELINES OF CLIMATE POSITIVE CIRCULAR COMMUNITY IN TRENTO**

**WP4 SUSTAINABLE BUILDING (RE) DESIGN**

This Annex contains:

1. the texts of the e-mail used for the dissemination of the questionnaire to involve End Users of the New Building (EV Charging HUB with integrated services) of the Trento demonstration project in the early concept design phase (in Italian);
2. the contents of the online questionnaire (in Italian).

## 1. ACCOMPANYING EMAIL

Indagine per raccogliere informazioni utili all'Università di Trento in merito alle esigenze ed aspettative degli utilizzatori di una infrastruttura di ricarica elettrica di pubblico accesso per auto/motocicli/biciclette

Gentilissimo/a,

si trasmette al seguente link <https://forms.gle/xwfabSZHqU1VmdPw5> un breve questionario all'interno del progetto europeo ARV.

ARV, finanziato nell'abito del Green Deal Europeo, esplora la possibilità di generare Comunità Circolari Climatiche e Positive (*Climate Positive Circular Communities - CPCCs*) che si basano sull'interazione e l'integrazione tra gli edifici, gli utenti e i sistemi locali di energia, mobilità e ICT. In particolare, stiamo lavorando per raccogliere informazioni in merito alle infrastrutture di ricarica per i veicoli elettrici o ibridi e conoscere la tua opinione sarebbe importante.

Le domande richiedono pochissimi minuti.

Si tratta di un questionario anonimo, i dati e le informazioni raccolte saranno trattate esclusivamente in forma aggregata. Non sarà diffusa o pubblicata nessuna informazione o risposta individuale.

Ringraziamo in anticipo per la preziosa collaborazione e restiamo a disposizione per eventuali dubbi.

Il questionario può essere diffuso a persone ed enti che ritieni possano essere potenzialmente interessati dall'indagine. Grazie!



**UNIVERSITÀ  
DI TRENTO**

Per eventuali richieste di informazioni, contattare [lpe.dicam@unitn.it](mailto:lpe.dicam@unitn.it)  
Persona di riferimento: prof. Rossano Albatici,  
DICAM, Università di Trento, via Mesiano 77

Sito web del progetto europeo ARV: <https://greendeal-arv.eu/2022/02/14/italy/>



## 2. QUESTIONNAIRE



Grazie in anticipo per aver deciso di dedicare qualche minuto alla compilazione del presente questionario. Le domande che seguiranno richiedono pochi minuti e ci permetteranno di raccogliere informazioni utili.

Ti informiamo, inoltre, che il questionario è anonimo e che i dati saranno trattati in forma aggregata.

### Domande

#### Età

- tra 18-25 anni
- tra i 25-50 anni
- tra 50-60 anni
- più di 60 anni

#### Dove vivi?

- in centro città/in centro di valle
- in periferia di una città/di un centro di valle
- in un piccolo paese/borgo
- altro (specificare) \_\_\_\_\_

#### Quale veicolo elettrico utilizzi abitualmente?

- auto Full Electric
- auto ibrida plug – in
- veicolo commerciale Full Electric o Ibrido plug-in
- scooter/moto/quadriciclo elettrico
- bicicletta a pedalata assistita

#### Dove lo ricarichi preferibilmente? È possibile selezionare più di una risposta.

- a casa da presa domestica o industriale
- a casa con wall box
- in azienda da presa domestica o industriale
- da colonnine di ricarica a pubblico accesso
- altro, specificare \_\_\_\_\_

**Quando lo ricarichi fuori casa come occupi il tempo?** È possibile selezionare più di una risposta.

- lavoro
- studio
- svago in prossimità della ricarica
- svago in luogo diverso dalla ricarica
- altro, specificare \_\_\_\_\_

**Ti soddisfano le stazioni di ricarica ad accesso pubblico che abitualmente utilizzi o talvolta hai utilizzato?**

- molto
- abbastanza
- poco
- per nulla

**Ritieni utile nelle vicinanze dei punti di ricarica la presenza di servizi/attrezzature per occupare il tempo di attesa?**

- molto
- abbastanza
- poco
- per niente

**Durante la ricarica del veicolo come ti piacerebbe occupare il tempo?** È possibile selezionare più di una risposta.

- rilassarsi
- lavorare
- usufruire di un piccolo bar o punto di ristoro
- stare con i propri figli/nipoti con l'opportunità di giocare con loro o farli giocare
- fare piccoli acquisti relativi al tuo veicolo o di altro genere
- noleggiare bicicletta o monopattino
- altro, specificare \_\_\_\_\_

**Se fosse presente nei pressi di una stazione di ricarica un ambiente chiuso cablato con connessione rete Wi-Fi, ritieni che possa essere utile?**

- molto
- abbastanza
- poco
- per niente

**Prima o dopo la ricarica del veicolo quali delle seguenti attività complementari potrebbero essere utili?** È possibile selezionare più di una risposta.

- autolavaggio
- autofficina
- altro, specificare \_\_\_\_\_
- nessuna attività

**Nella stazione di ricarica attrezzata, ritieni utile la presenza di un'area per bambini?**

- molto
- abbastanza
- poco
- per niente

**Nella stazione di ricarica attrezzata, ritieni utile uno spazio informativo per cittadini/turisti con disponibilità di materiale informativo e promozionale del territorio di competenza?**

- molto
- abbastanza
- poco
- per nulla

**Nella stazione di ricarica attrezzata, ritieni importante la presenza di servizi igienici?**

- molto
- abbastanza
- poco
- per nulla

**Dove vorresti fosse localizzata una stazione di ricarica attrezzata? È possibile selezionare più di una risposta.**

- nei pressi di un ampio parcheggio
- nei pressi di una stazione di rifornimento di carburante
- in prossimità di un centro commerciale
- in autostrada e/o al suo ingresso/uscita
- sulle arterie di collegamento
- altro, specificare \_\_\_\_\_



CLIMATE POSITIVE CIRCULAR COMMUNITIES

## **ANNEX**

### 9.3.4 Summary report of the online survey

**D4.5 DESIGN GUIDELINES OF CLIMATE POSITIVE CIRCULAR COMMUNITY IN TRENTO**

**WP4 SUSTAINABLE BUILDING (RE) DESIGN**

This Annex contains the results of the online survey developed by UNITN to involve End Users in the Early Concept Design phase of the New Building (EV Charging HUB with integrated services) for the Trento demonstration project.

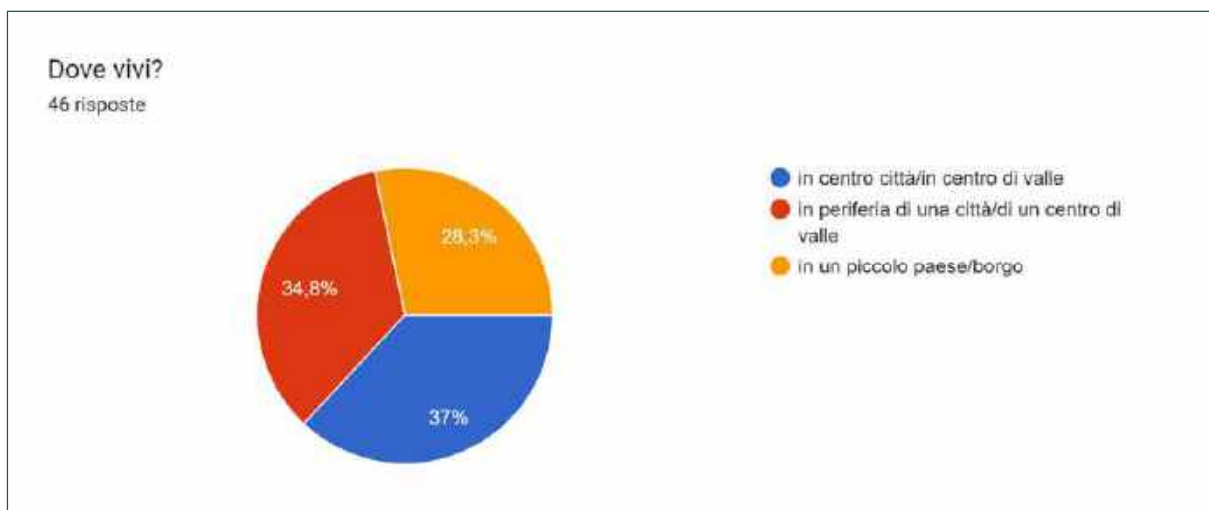
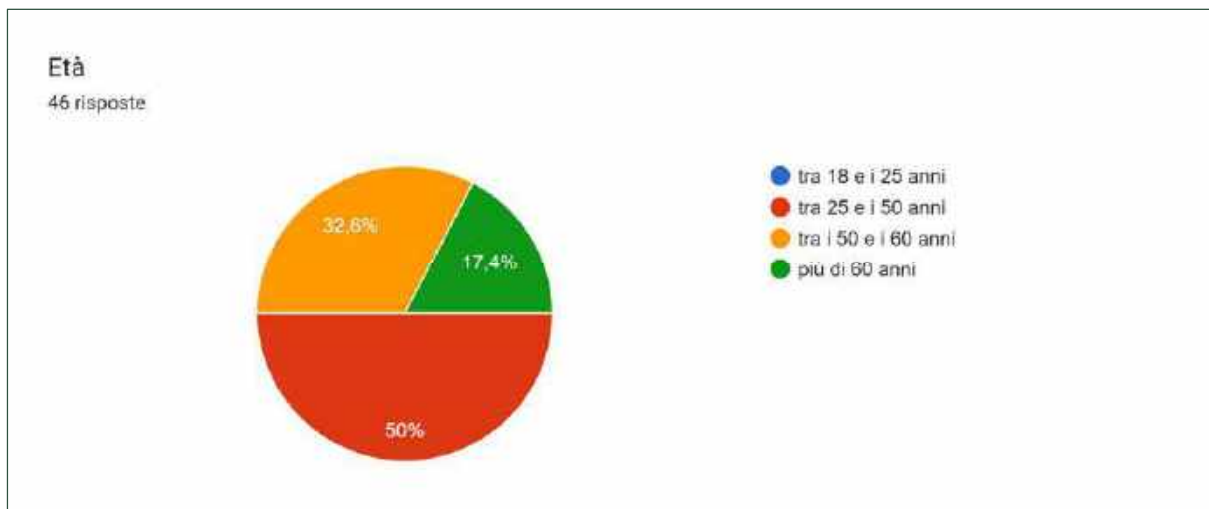
In particular, the questionnaire serves a dual purpose of:

- a) investigating the need/expectations of citizens who are owners or users of electric or hybrid vehicles on possible services that could improve the recharging and waiting times at dedicated stations;
- b) communicating and promoting the ARV project and the importance of citizens' engagement in the same.

46 people replied to the questionnaire on 24/11/2022.

The questionnaire was administered in Italian using a google form (gform). The original graphs processed automatically by the gform are shown below.

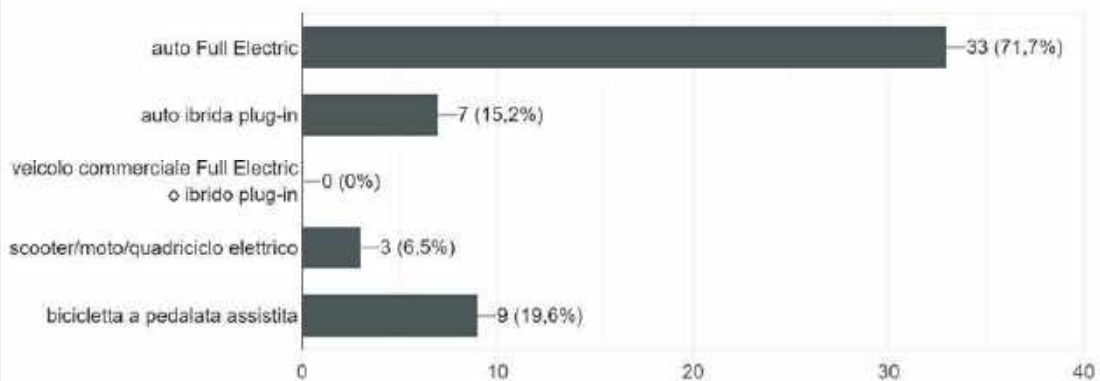
## RESULTS OF THE QUESTIONNAIRE





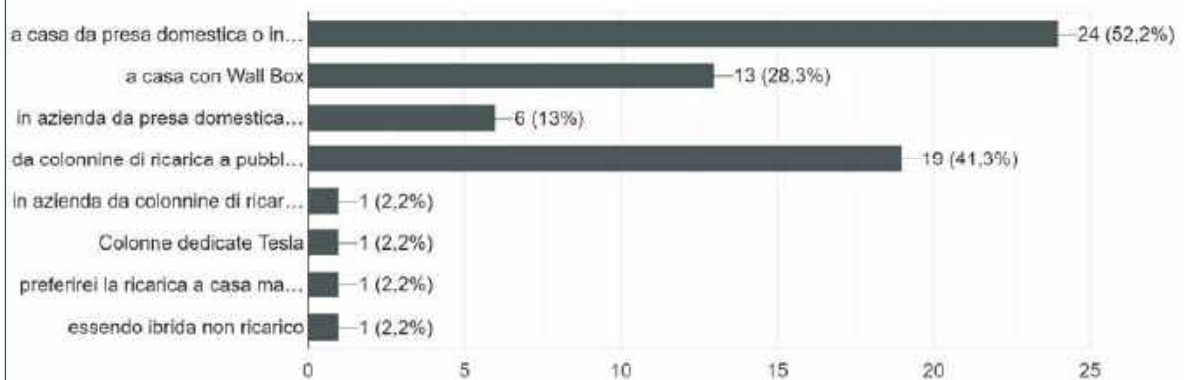
### Quale veicolo elettrico utilizzi abitualmente?

46 risposte



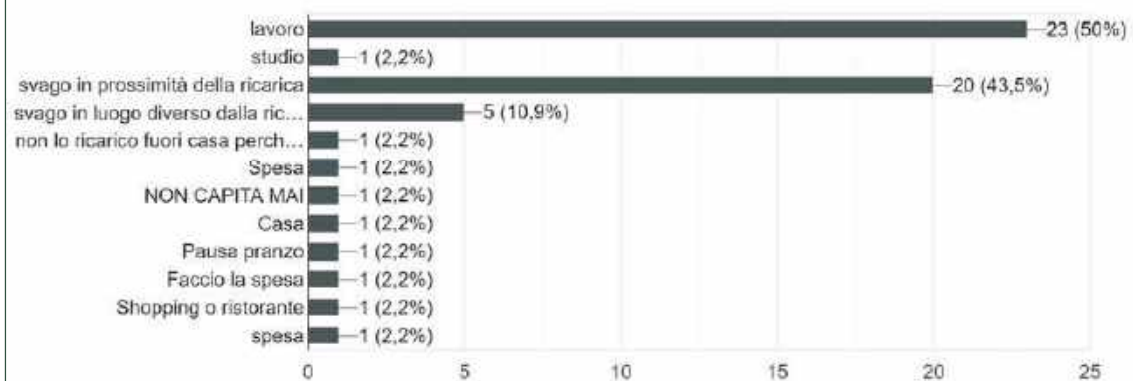
### Dove lo ricarichi preferibilmente?

46 risposte



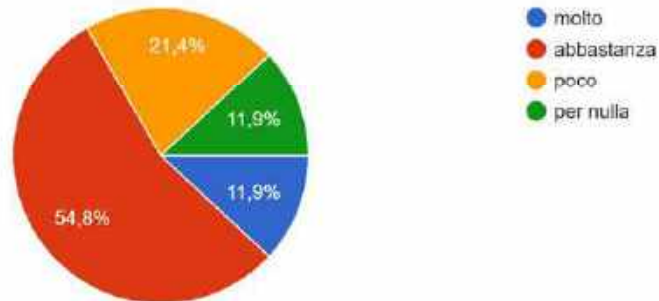
### Quando lo ricarichi fuori casa come occupi il tempo?

46 risposte



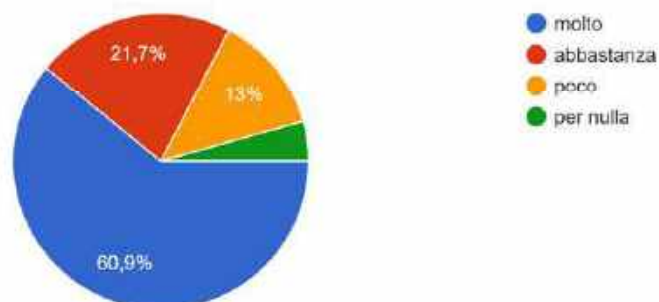
Ti soddisfano le stazioni di ricarica ad accesso pubblico che abitualmente utilizzi o talvolta hai utilizzato?

42 risposte



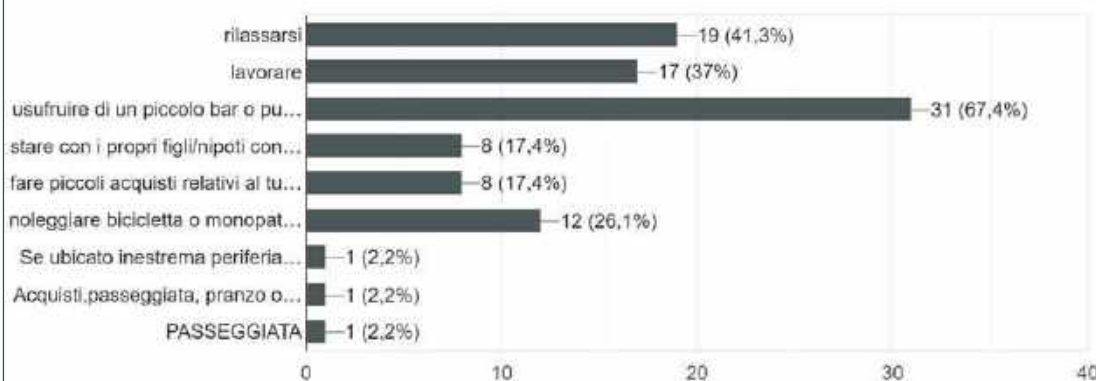
Ritieni utile nelle vicinanze dei punti di ricarica la presenza di servizi/attrezzature per occupare il tempo di attesa?

46 risposte



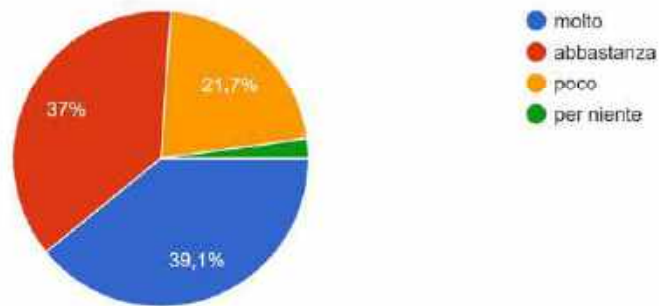
Durante la ricarica del veicolo come ti piacerebbe occupare il tempo?

46 risposte



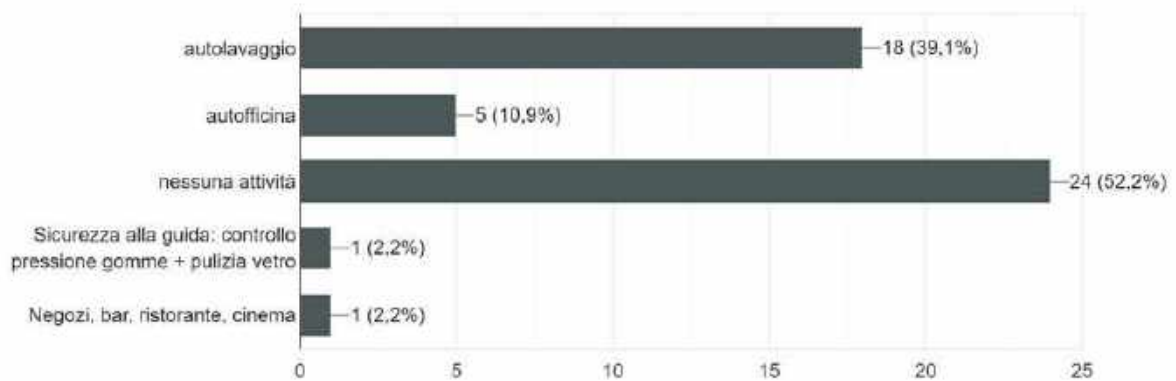
Se fosse presente nei pressi di una stazione di ricarica un ambiente chiuso cablato con connessione rete Wi-Fi, ritieni che possa essere utile?

46 risposte



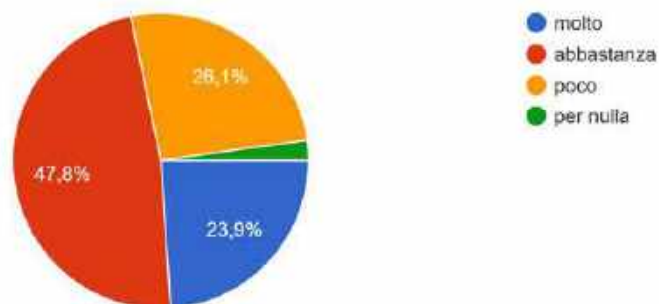
Prima o dopo la ricarica del veicolo quali delle seguenti attività complementari potrebbero essere utili?

46 risposte



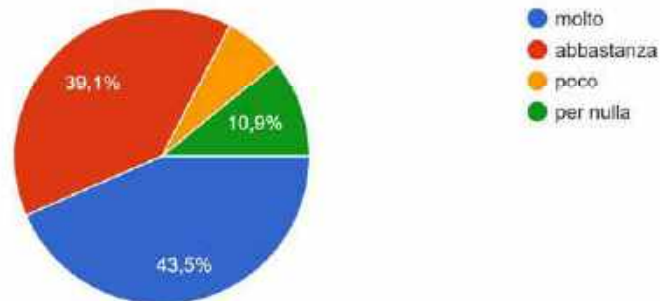
Nella stazione di ricarica attrezzata, ritieni utile la presenza di un'AREA PER BAMBINI?

46 risposte



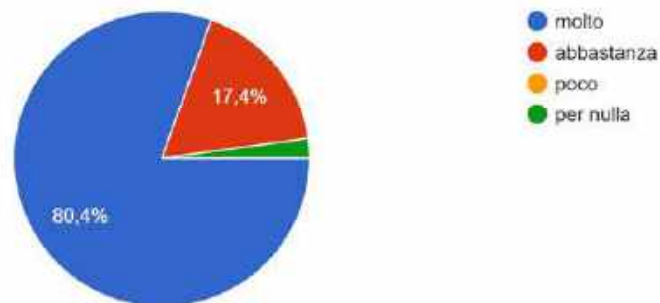
Nella stazione di ricarica attrezzata, ritieni utile uno SPAZIO INFORMATIVO per cittadini/turisti con disponibilità di materiale informativo e promozionale del territorio di competenza?

46 risposte



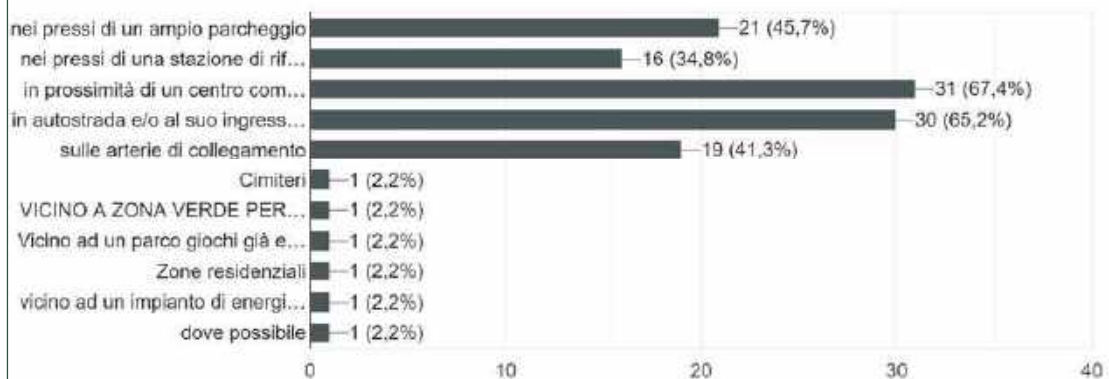
Nella stazione di ricarica attrezzata, ritieni importante la presenza di SERVIZI IGIENICI?

46 risposte



Dove vorresti fosse localizzata una stazione di ricarica attrezzata?

46 risposte



The following information emerges from the online questionnaire which also contains questions with the possibility of selecting one or more answers.

The age groups of participants are: between 25 and 50 years old (50%), between 50 and 60 years old (33%) and over 60 years (17%).

72% of respondents use a full electric car, 15% a plug-in hybrid car, 6.5% an electric scooter and 19.6% an electric bicycle.

52% of the participants recharge their e-vehicle at home with a domestic socket and 28% at home with a wall box, but 41% also recharge from public charging stations, and 13% in the company or in the workplace (if there is the possibility).

When the e-vehicle is not being recharged at home, respondents use the waiting time to work (50%), to relax at the charging station (44%) or somewhere other than the charging station (12%).

The public charging stations usually used fully satisfy only about 12% of respondents; in fact, the presence of services and/or equipment to occupy waiting time at the charging station are useful for 83% of the respondents. To this end, the wishes expressed refer to the following activities: the presence of a small café (67%); the possibility of relaxing (41%), working (37%), renting a bicycle or scooter (26%), spending time with one's children (17%) and doing small shopping (17%). In addition, the presence of a wired environment with a Wi-Fi connection is useful for 76% of participants.

39% of respondents favour the presence of a car wash at the charging station and 11% wish a car workshop. Almost all respondents (97%) require toilets; 83% of respondents agree on the usefulness of an information point for citizens/tourists with promotional material about the area and 72% would like the presence of a children's area.

Finally, as regards the location of the equipped charging station, the options most frequently expressed by participants are: in a large car park (46%), near the entrance to a motorway (65%) and near a shopping centre (67%).





CLIMATE POSITIVE CIRCULAR COMMUNITIES

## **ANNEX**



### 9.3.5 Paper published on *Buildings* journal

D4.5 DESIGN GUIDELINES OF CLIMATE POSITIVE CIRCULAR COMMUNITY IN TRENTO

WP4 SUSTAINABLE BUILDING (RE) DESIGN

Review

# Natural and Mechanical Ventilation Concepts for Indoor Comfort and Well-Being with a Sustainable Design Perspective: A Systematic Review

Luca Zaniboni <sup>1,2,\*</sup>  and Rossano Albatici <sup>1</sup> 

<sup>1</sup> Department of Civil, Environmental and Mechanical Engineering, University of Trento, Via Mesiano 77, 38123 Trento, Italy

<sup>2</sup> Department of Environmental and Resource Engineering, Indoor Environment, Technical University of Denmark, Koppels Allé, 402, 231, 2800 Kongens Lyngby, Denmark

\* Correspondence: luczan@dtu.dk

**Abstract:** Current literature and guidelines on sustainable design often debate on the advantages of natural ventilation (NV) and mechanical ventilation (MV) on indoor environment and energy consumption. The present systematic review explores the existing literature comparing NV and MV on the indoor comfort and well-being points of view. The findings emphasize that thermo-hygrometric comfort is the main driver of occupants' ventilation behavior, while ventilation design is mainly led by indoor air quality targets. Moreover, more recent papers (especially after COVID-19 outbreak) emphasize the necessity of a health-based approach, contrasting airborne pathogens transmission. In this sense, MV is more frequently recommended in public spaces, while hybrid ventilation (HV) is often suggested as a solution to both ensure proper indoor conditions and energy savings. The concept of well-being is currently under-explored, as the present literature only refers to comfort. The same happens with topics such as visual, acoustic, and multi-domain comfort, as well as passive techniques such as night cooling, or analysis of specific environments such as healthcare facilities. Current knowledge would benefit from an expansion of future research in these directions. The choice of the best ventilation solution cannot ignore the context, type, and condition of energy efficient buildings, in order to properly take into account occupants' well-being.

**Keywords:** building ventilation; indoor comfort; well-being; energy saving; climate-responsive design



**Citation:** Zaniboni, L.; Albatici, R. Natural and Mechanical Ventilation Concepts for Indoor Comfort and Well-Being with a Sustainable Design Perspective: A Systematic Review. *Buildings* **2022**, *12*, 1983. <https://doi.org/10.3390/buildings12111983>

Academic Editors: Laura Canale and Biagio Di Pietra

Received: 18 October 2022

Accepted: 10 November 2022

Published: 15 November 2022

**Publisher's Note:** MDPI stays neutral with regard to jurisdictional claims in published maps and institutional affiliations.



**Copyright:** © 2022 by the authors. Licensee MDPI, Basel, Switzerland. This article is an open access article distributed under the terms and conditions of the Creative Commons Attribution (CC BY) license (<https://creativecommons.org/licenses/by/4.0/>).

## 1. Introduction

It is well-recognized that the building sector has a key role in the framework of energy savings, being responsible for 40% of energy consumption and 36% of emissions of greenhouse gasses in the European Union [1]. For this reason, design concepts such as net-zero energy buildings (nZEBs), net-positive energy buildings (nPEBs), and climate-responsive architecture are fundamental to reduce the carbon footprint. In fact, in nZEBs the total annual energy balance (produced minus consumed) is equal to zero [2,3], while in nPEBs the balance is even positive [4,5]. On the other hand, climate-responsive design allows the creation of a structure intrinsically connected with building location, using responsive technologies to improve the performance of buildings [6–12]. Furthermore, indoor well-being cannot be neglected in buildings' design. The well-being concept is heterogeneous, and efforts have been made to define it. Nevertheless, the two aspects of environmental comfort and satisfaction, as well as cognitive performance, health, and productivity, emerge in the building context [13]. Therefore, a good definition of well-being regards it as the combination of feeling good and functioning well [14]. For these reasons, good indoor air quality (IAQ), thermal, acoustic, and visual conditions, and their interaction (multi-domain approach) as all part of the indoor environmental quality (IEQ), are fundamental not only for health and comfort, but also for other aspects such as physiological and psychological

ones (e.g., working performance) and, since occupants tend to take action to make themselves comfortable, energy consumption [15–22]. Occupants can suffer from illnesses and complaints related with comfort, health, and safety in several indoor spaces [23]. Since the World Health Organization (WHO) Sick Building Syndrome declaration in 1986, IAQ, connected with health and comfort, has been strongly considered in indoor design [24,25]. In fact, several pollutants might be present in internal environments, with an adequate air-supply rate necessary to ensure healthy conditions for occupants [26–28]. In this complex framework, ventilation has a key and fundamental role, since it has high impact on both buildings' energy consumption and IEQ. Depending on the ventilation technique, which can be used in combination with other passive solutions such as the use of thermal inertia for night cooling and shadings to avoid solar heat peaks, the carbon footprint can be consistently lowered [29–35]. Moreover, ventilation choice cannot overlook the well-being of occupants, which needs to be the primary aim of indoor design [25,31].

Generally speaking, ventilation techniques can be divided into three main groups: natural ventilation (NV), mechanical ventilation (MV), and hybrid or mixed mode ventilation (HV or MMV). Each of these categories have different implications on energy consumed and comfort. NV, totally relying on natural forces (wind- or buoyancy-driven), can consistently lower buildings' carbon footprint [36–40]. Moreover, the acceptable range of thermal comfort was noticed to be enlarged when NV is present, with higher acceptance of high indoor temperatures when outdoor temperatures are high too [41,42]. This led to the introduction of the adaptive model for naturally ventilated buildings on ASHRAE Standard 55, which is now used together with Fanger's model in naturally ventilated buildings [41,43–45]. In addition to that, NV might be associated with benefits related with environmental and work satisfaction, productivity, and Sick Building Syndrome, as well as improved feeling of control for occupants and access to the outside environment [30,36,46–55]. The use of NV is suggested by Leadership in Energy and Environmental Design (LEED), in order to decrease both the carbon footprint and heating, ventilation, and air conditioning (HVAC) expenses. In this sense, positive correlations between fulfilled LEED rating and satisfaction perceived was demonstrated [56]. Conversely, the possibility to fully regulate temperature, airflow, and air velocity is a clear advantage of MV, of which performance is perfectly predictable and controllable if compared with NV, with positive implications on the IAQ [25,47,57–59]. The use of heat recovery units can partially overcome the drawback of the larger amount of energy with respect to NV [60–63]. Finally, HV can be a good compromise between the two techniques, guaranteeing energy savings, but exploiting MV when proper IEQ conditions cannot be met with NV only [29,30,55,64–69]. Current literature and standards argue on which of the two techniques should be preferred. Controversial opinions about this topic were also highlighted by the COVID-19 pandemic [70]. In fact, the risk of infection is strongly dependent on relative humidity (RH), temperature (T), and ventilation [71]. In this framework, ASHRAE recommended to use NV only in homes where MV or air-purifiers were not installed, in order to avoid thermal discomfort [72–74]. On the other hand, NV was also associated with the buildings' infection management [75,76]. In fact, CIBSE and REHVA recommended massive use of window openings, even in mechanically ventilated buildings and in winter [77,78]. Moreover, during London's lockdown, windows were noticed to be associated with positive cross influences of indoor mental well-being due to positive perceived soundscapes, vegetation view, and natural sounds [48,49]. In a global warming condition, the adaptive comfort model might cease to be fulfilled in plenty of indoor spaces in the next ten years [79], but a higher use of NV in colder climates might be induced by the shifting of climate conditions [30].

In this framework, it is clear that when dealing with concepts such as nZEBs, nPEBs, and climate-responsive architecture, the choice of ventilation technique is of paramount importance. Moreover, comfort and well-being should be among the main drivers in buildings' design, and therefore a strong literature background on how each type of ventilation influences comfort at different climates and seasonal conditions constitutes an important basis for proper design choices.

The aim of the present review to provide a framework on scientific evidence of papers comparing NV and MV in terms of comfort and well-being, in the perspective of performant and sustainable buildings' design (e.g., nZEBs, nPEBs, and climate-responsive buildings). The main hypothesis is that ventilation is firstly aimed to provide IEQ, with energy savings as a very important additional aim. For this reason, the following research questions were explored:

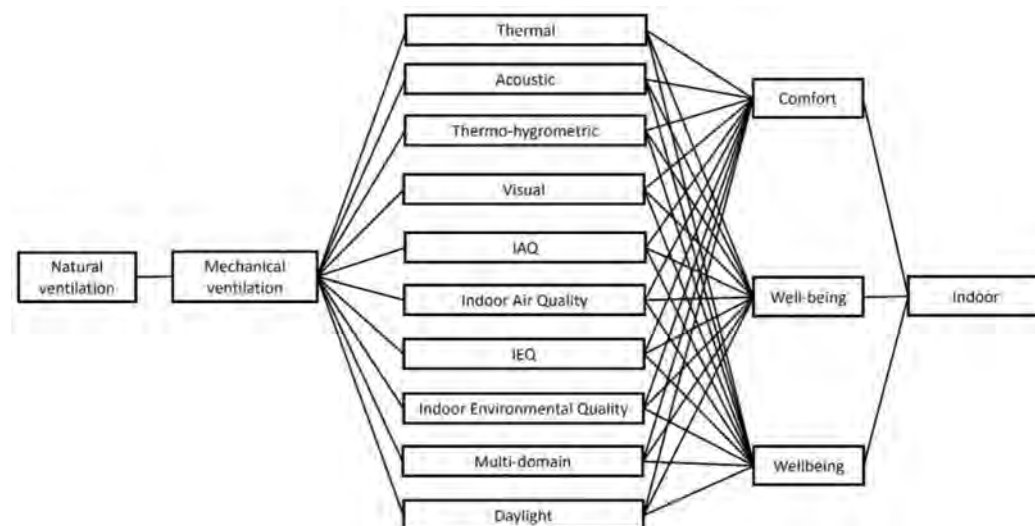
1. Which differences are present between IEQ conditions guaranteed by NV and MV?
2. Which ventilation techniques are more suitable at different climatic, seasonal, and outdoor pollution conditions according to both IEQ and energy perspectives?
3. Which ventilation techniques are more suitable with different building types and uses?
4. Which are the research gaps in terms of effects of NV and MV on the IEQ, depending on the type of building, the ventilation technique and the comfort domain considered?

If integrated with other studies, the articles here summarized can be exploited by policymakers in order to further expand and update ventilation standards and guidelines taking into account both energy consumption and indoor well-being. The development of such guidelines is fundamental for engineers, architects, and planners in order to help them in conscious and contemplated choices during the design process.

## 2. Methodology

### 2.1. Research Methodology

A systematic review [80] was performed using AND/OR Boolean operators [13] in a search on the Web of Science [81] database. The search was aimed at identifying all the studies regarding an NV-MV comparison in terms of comfort and well-being. Figure 1 reports the detailed search string used. The PRISMA flow diagram was used in the systematic review process [82].



**Figure 1.** Boolean search string used for the first papers' search query. Keywords on the same column were linked with the "OR" operator, while black lines represent the "AND" operator.

### 2.2. Inclusion Criteria and Screening Process

All types of articles (journal papers, reviews, and conference proceedings) were included. In order to refine the research, considering only the relevant works, the following inclusion–exclusion process was applied:

1. Limiting of the research to English-written studies within the following research areas: (a) construction building technology; (b) engineering civil; (c) engineering environmental; (d) green sustainable science technology; (e) environmental sciences; (f) public environmental occupational health; (g) environmental studies; (h) architecture;

- (i) thermodynamics; (j) engineering mechanical; (k) infectious diseases; (l) regional urban planning; (m) urban studies;
- 2. Titles and abstracts screening, rejecting all the papers not in compliance with the research questions, thus not comparing NV and MV on a comfort and/or well-being point of view;
- 3. Rejection of the studies which full text was not available;
- 4. Full papers' reading.

### 2.3. Categorization and Data Analysis

Based on the aim of the present research, selected studies were categorized according to different criteria:

1. Type of environment considered (residential, educational, working, healthcare, etc.);
2. Type of paper (journal paper, journal review, and conference proceedings);
3. Comfort domain analyzed by the paper (thermo-hygrometric, visual, IAQ, acoustic, or multi-domain);
4. Type of ventilation recommended, between "NV only", "MV only", "HV (or both HV and NV)", "no clear preference stated".

The geographical area and/or climate the studies were related to were also highlighted when applicable and specified. In the framework of sustainable design such as nZEB, nPEB, and climate-responsive architecture, outcomes in terms of energy consumption and savings were also highlighted. Moreover, when related with NV and when specified, the ventilation aim was also considered, dividing between air change, thermal regulation, and night cooling (as a more specific type of thermal regulation with remarkable passive design applications) [32,33,41,75,83–86]. Keyword co-occurrence analyses were performed by means of the software *VOSviewer 1.6.18*. Further statistics based on the publication year and publication geographic area were also considered.

## 3. Results

### 3.1. General Data and Statistics

Details about the number of papers found after each screening phase are reported in Figure 2. A total number of 94 papers was firstly found, with 68 eligible for full paper reading. After this last process, six more papers were rejected, with a final number of 62 papers considered and analyzed in this essay. Further details on the selection process are available in a PRISMA flow diagram in Figure A1 in Appendix A. Most of the included articles (71.0%) are journal papers, followed by reviews (19.4%), and conference papers (9.7%) (Figure 3).

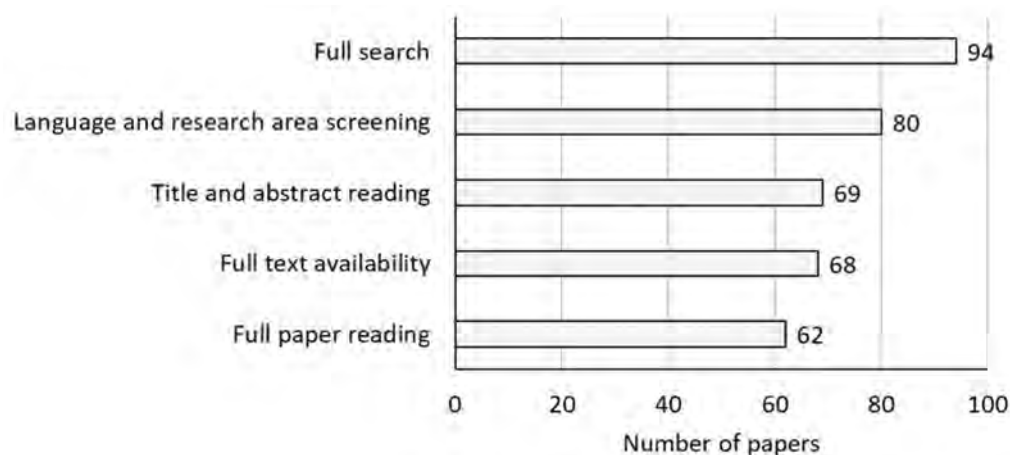
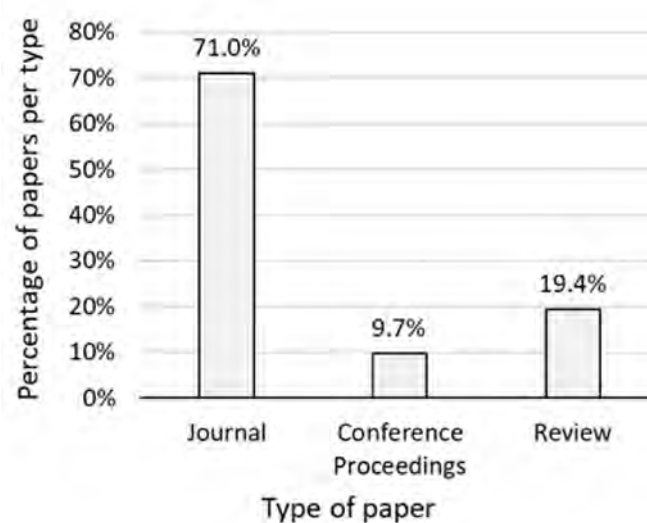


Figure 2. Papers found after each phase of the screening process.

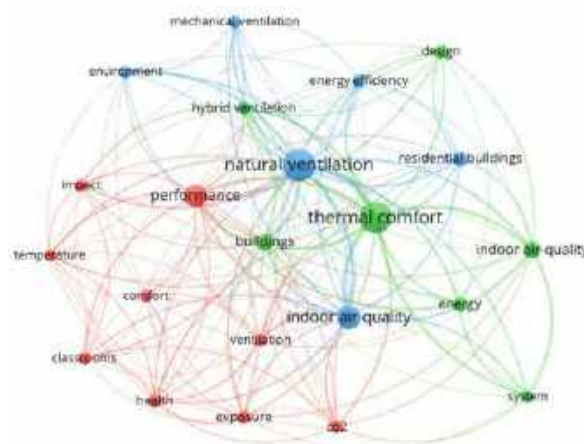




**Figure 3.** Percentage of papers per type.

Figure A2 shows the number of papers per publication year. It is clear that, starting from 1994, the topic gained a growing interest, with the number of published papers rising year by year (i.e., one in 1994, five in 2021). It is also interesting to notice that year 2020, during the COVID-19 pandemic, showed a peak in the number of papers (9), due to the obvious necessity to deepen the knowledge into ventilation related with infection airborne transmittance. Figure A3 depicts how the majority of the included articles were European (47.0%) and Asian (31.3%). On the other hand, only 4.8% of the papers were African, and none were South American. Details in Figure A4 show that England is the major publisher of included papers (11), followed by China (10), and USA (6).

Eventually, Figure 4 shows the co-occurrence keywords analysis (minimum occurrence number set equal to five for the representation) of the articles included in the present review. With 28 and 27 occurrences respectively, “natural ventilation” and “thermal comfort” were the most frequent keywords. “Indoor air quality” (in the three forms of “Indoor air quality”, “Indoor air-quality” and “IAQ”) was found 26 times in total. On the other hand, visual and acoustic comfort domains were not frequently explored (“acoustic” and “noise” appeared respectively one and two times, while “daylighting” appeared only once). Furthermore, it is important to highlight that neither the “well-being” nor the “wellbeing” keywords appeared in the articles included.



**Figure 4.** Co-occurrence keywords analysis of the articles included performed with *VOSviewer 1.6.18*, considering the keywords with a minimum number of occurrence equal to 5.

### 3.2. Papers Related with Residential Environments

In this subsection, results related with papers discussing NV and MV comfort comparison in residential environments are reported. A total number of eighteen articles were found, mainly journal papers (13) and conference papers (4), with only one literature review (1). The highest number of these research (9) were related to case studies located in Europe, followed by Asia (6), Oceania (2), and Africa (1). Ventilation for thermal regulation and ventilation for air change were analyzed, generally with a direct correspondence with thermo-hygrometric comfort and IAQ respectively. Night cooling was also considered in some cases, even though it was mainly listed as a way to better exploit NV. Thermo-hygrometric was the comfort domain most frequently considered by the papers here analyzed (15 articles out of 18), followed by IAQ (10 articles) and acoustics (6 papers). One paper considering visual and multi-domain comfort was found. Contrasting conclusions on which ventilation type is preferable on the comfort point of view were found, as well as regarding the system providing higher energy savings. Brief summaries of the main findings are reported in this Subsection, in Table 1. The details concerning each paper, key data (type of paper, climate, and ventilation considered and suggested), comfort domains treated and main conclusions are present in Table S1 (available as Supplementary Materials).

**Table 1.** Key findings related with residential environments.

<b>Thermo-Hygrometric Comfort</b>		
	<b>Main findings</b>	<b>References</b>
	Improvement of thermal comfort or temperature control conditions when using MV or HV, especially when hotter or colder outdoor conditions are present	[87–93]
	Good or better performance of NV in terms of thermal comfort	[94,95]
	Thermal comfort is one of the main drivers of occupants' behavior associated with NV, with the air change rate and windows opening being dependent on outdoor temperature	[88,96,97]
	Necessity of proper design of buildings where NV is planned to be exploited for thermal comfort (architectural elements, windows, openings, orientation, control, etc.)	[98–101]
	In a Chinese students' dormitory during winter, temperature and humidity decreased to values under 20 °C and 30% after 4 h of night ventilation with ventilation rates of 0.050 m <sup>3</sup> /s and 0.036 m <sup>3</sup> /s, respectively	[100]
	Too low or too high building tightness is associated with condensation risks	[96]
	Too low or too high building tightness is associated with draughts or fluctuating temperature	[101]
	In a temperate continental city of China, humidification was seen as an issue with both NV and MV, and occupants perceived drier conditions with MV	[95]
	In developing countries, comfort range with NV might be larger (14.6–26.3 °C of comfort range found in an Ethiopian case study), allowing to satisfactorily exploit this ventilation technique	[94]
	Thermal comfort, health, and energy savings are the three drivers of ventilation behavior	[97]
<b>Visual comfort</b>		
	<b>Main findings</b>	<b>References</b>
	A higher probability of windows opening was observed in Italy during 2020 winter lockdown, where a vegetation view was present	[102]
<b>IAQ</b>		
	<b>Main findings</b>	<b>References</b>
	Even though their priority is thermal comfort, occupants seem to be more inclined to spend more on energy if healthier environments can be provided	[97]
	The use of MV is associated with better air quality or sweeping effect	[87,88,101,103]
	MV can mitigate air-tightness issues (lowering the radon concentration from 412 Bq/m <sup>3</sup> to 70 Bq/m <sup>3</sup> , and the CO <sub>2</sub> concentration to an average around 760 ppm in a Romanian case study)	[87]

Table 1. Cont.

<b>Thermo-Hygrometric Comfort</b>		
	Direct link between air change rate (and ventilation behavior) and IAQ conditions	[96,100]
	IAQ conditions are strongly dependent on outdoor conditions or air tightness of buildings	[92,95,103]
	HV can be a solution when proper IAQ conditions cannot be met with NV alone	[100,104]
<b>Acoustic comfort</b>		
	<b>Main findings</b>	<b>References</b>
	Noise from both outdoors (NV) and systems (MV) can be a discomfort source	[91,92,97,101]
	Together with thermal discomfort and stuffy air, noise can be one of the factors reducing the quality of sleep	[88]
	During 2020 winter lockdown in Italy and UK, tendency by occupants to keep windows open, at least sometimes, even in urban areas. Necessity to include the concept of pleasant acoustic contexts in standards. Proposal of introduction of an “adaptive acoustic comfort” concept	[102]
<b>Multi-domain</b>		
	<b>Main findings</b>	<b>References</b>
	Study and application of multi-domain concept would be fundamental for the definition of acoustic criteria in naturally ventilated buildings	[102]
<b>Energy consumption and other issues</b>		
	<b>Main findings</b>	<b>References</b>
	MV can allow for reduction in consumption, due to less windows openings	[96]
	MV can allow for reduction in consumption, due to the use of heat recovery (86% reduction found with respect to NV)	[87]
	NV allows for less demand of energy	[91,93,95]
	NV can be exploited with not extreme temperatures or not too high outdoor PM <sub>2.5</sub> concentration	[95]
	Increase in energy consumption up to 20% found with MV in simulative study performed in Mediterranean climate: NV with night cooling suggested for smaller residential buildings, and MV or HV for larger residential or commercial ones	[91]
	NV can allow for large energy savings in developing countries (wide comfort range in a field study in Ethiopia). Further research suggested to confirm this conclusion	[94]
	Thermal comfort, health, and energy savings are the three drivers of ventilation behavior	[97]
	Feasibility, safety, and life cycle costs need to be preliminary analyzed in the design process	[91]
	Computational Fluid Dynamics (CFDs) simulations used or encouraged by a significant amount of studies, in order to study air movement and comfort induced by NV or HV	[89,90,98,99]

### 3.3. Papers Related with Non-Residential Environments

Works related with non-residential environments are here reported. Thirty-one papers were categorized within this group: twenty-five journal papers, two conference papers, and four reviews. Moreover, in this case, most articles were related to case studies located in Europe (12). Five case studies were in Asia and five in North America, while only one case study was in South America, one in Oceania, and one in Africa. One simulative study considered three climate areas, two in Europe and one in Asia. The articles here grouped mainly regard educational (12) and working environments (14). Articles regarding other facilities, such as industrial or healthcare, are also present. Moreover, in the case of non-residential buildings, thermo-hygrometric was the most explored domain (29 papers out of 31), followed by IAQ (21 papers), acoustic (10), and visual (6). Only three articles linkable with the multi-domain concept were found. Present literature is debating whether MV or NV provide better thermo-hygrometric comfort conditions in non-residential buildings. Moreover, similarly to what concerned residential buildings, while papers related with thermo-hygrometric comfort were mainly considering ventilation for thermal regulation,

air change was the main focus of studies dealing with IAQ. Visual, acoustic, and multi-domain comfort were only marginally treated. It is finally fundamental to highlight how, after the pandemic, the main focus of the design seems to have changed to the control of pathogens transmission. Key findings are summarized in Table 2, while specific details about each article are reported in Table S2 (Supplementary Materials).

**Table 2.** Key findings related with non-residential environments.

<b>Thermo-Hygrometric Comfort</b>		
	<b>Main findings</b>	<b>References</b>
	In monitored classrooms in Beijing, both systems provided a too low temperature (below 18 °C) close to the beginning and the end of running heating period	[105]
	1.5 ach <sup>-1</sup> MV suggested in nucleus-type hospitals, in order to provide comfort conditions	[106]
	Personalized ventilation suggested in order to have thermal benefits for occupants	[107]
	NV alone is not sufficient to ensure thermal comfort in a large semi-transparent ceiling ocean park case study	[108]
	NV or HV can be adequate to provide thermal comfort	[30,55,64,67,109–115]
	During summer in Dubai, when NV is not sufficient, despite the too high outdoor temperature and too low wind, a reduction of 2–6 °C is possible in office buildings by NV	[109]
	Definition of 7 °C outdoor temperature as lower boundary for NV to be ineffective	[115]
	Definition of the range of applicability of NV between 10 °C and 25 °C of outdoor temperature	[30]
	Preference for NV is often related with the higher degree of control of occupants	[25,30,55,111,116]
	The negative effects of NV on productivity are under debate	[111]
	A higher productivity by men workers when HV was used instead of MV was found in an office of Tokyo (Japan)	[114]
	Dependence of thermo-hygrometric comfort on outdoor temperature and users' behavior	[29,60,67]
	Due to global warming, NV use will decrease at warmer climates, simultaneously increasing in colder and mild areas	[30]
	HV can be used when non-optimal conditions are achievable with NV only	[67,109,117,118]
	Nighttime ventilation and night cooling can be exploited to enhance daily thermal comfort conditions	[30,67]
	Specific discomfort conditions (draught, too low temperatures) found with colder outdoor conditions	[117,119,120]
	The too low temperatures (around 18 °C) measured in Spanish schools during winter 2021 are admissible only during an emergency situation such as the pandemic	[119]
	Importance of particular solutions such as temperature monitoring in schools, local discomfort avoidance (by means of humidifiers, electric heaters of exhaust heat recoveries), building orientation, proper design of the exhaust velocity	[66,112,119,120]
	Importance of exhaust velocity optimization (e.g., depending on internal source of heat) in order to maximize thermal comfort and energy efficiency and minimize the short-circuiting risk	[66]
<b>Visual comfort</b>		
	<b>Main finding</b>	<b>References</b>
	Together with IAQ and acoustic, lighting is one of the IEQ aspects which needs deeper studies connected with NV	[111]
	Daylight benefits of similar constructive techniques used for NV exploitation, such as operable skylights or high windows. Direct sunlight and large glazed façades can lead to drawbacks on both sides (i.e., overheating and glare)	[30]
	Double-skin façades studied for NV have also the capability to provide natural light	[112]
	Aspect considered in the study, without direct findings related with NV and MV	[55,106,117]

Table 2. Cont.

<b>Thermo-Hygrometric Comfort</b>		
<b>IAQ</b>		
	<b>Main findings</b>	<b>References</b>
	MV can help in providing optimal IAQ	[25,60,107,120–124]
	Higher IAQ satisfaction in NV buildings	[113]
	Small or no difference in the perception with the two modes	[125]
	Difference in the indoor environmental conditions perceived and actually present indoor	[117]
	The presence of operable windows can provide a feeling of fresh air perception	[55]
	Use of HV recommended, exploiting MV when not sufficient IAQ can be maintained with NV (e.g., too polluted outdoor conditions)	[67,117,118]
	NV might not be sufficient in air-tight buildings	[120]
	NV will benefit from low polluting mobility solutions such as electric vehicles	[30]
	Most standards focus on perceived IAQ and CO <sub>2</sub> concentration or energy consumption, but several comfort, performance, and health issues are often reported in buildings: necessity to move from a comfort-based to a health-based design. In this sense, benefits can be obtained by the use of personalized ventilation	[107]
	Poorly designed or operated ventilation can lead to poor IAQ, which can cause virus airborne transmission due to dry conditions in winter: necessity the adoption of health-based ventilation design	[25]
	CO <sub>2</sub> concentration reduction (1000 ppm, with a 1400 ppm decrease) in Spanish schools during the pandemic, due to the most frequent airing	[119]
	Importance of having long and frequent airing periods with NV	[67,118,121,126]
	Suggestion of automated windows and/or CO <sub>2</sub> and pollutants monitoring devices	[117–119,122]
<b>Acoustic comfort</b>		
	<b>Main findings</b>	<b>References</b>
	Loud noise reported as one factor preventing the use of MV in Spanish schools	[119]
	Importance of noise evaluation when designing the ventilation solution	[67,105,118]
	Evaluation of noise with measurements or surveys in studies related with NV and MV	[55,117,122,123]
	In university classrooms, the intermittent noise of intermittent windows was better tolerated than the continuous one of MV	[117]
	Benefits from less noisy mobility will be provided to NV	[30]
	Acoustics related with NV will need further studies in the future	[111]
<b>Multi-domain</b>		
	<b>Main findings</b>	<b>References</b>
	IAQ has the potential to influence the other comfort domains (e.g., higher noise with higher IAQ due to higher machines regimes, sunlight causing surfaces' emissions of pollutants). These aspects should be evaluated and studied altogether to assure comfort and health of occupants	[107]
	Importance of deepening the studies of all the comfort aspects which are related to NV	[111]
	Direct association of noise level and IAQ with MV	[123]
<b>Energy consumption and other issues</b>		
	<b>Main findings</b>	<b>References</b>
	NV or HV allow to save energy	[29,30,67,105,110,111,114,117–119,125,126]
	Energy savings of ranging from 3.1 to 85% (coupling it with PV- system) reported with the use of NV or HV	[114]



Table 2. Cont.

Thermo-Hygrometric Comfort	
Not using adaptive model encouraging NV in green certification systems, might obstruct designers' and occupants' change in decision	[111]
NV is widely used in schools of developing countries, in order to save energy	[127]
If properly designed and with the use of proper techniques (energy storage or heat recovery), reduction in energy consumption can be achieved with MV	[121,124]
Automatic windows coupled with heat recovery counter-flow system through outside wall slots can reduce the energy consumed in classrooms	[122]
Careful design of ventilation (architecture, presence of heat recovery, technological solutions such as occupancy sensors, temperature or CO <sub>2</sub> monitoring, night cooling coupled with massive elements) encouraged in order to reduce the carbon footprint	[29,66,67,106,109,118–120,123,124,126,127].
The use of local climate conditions instead of international standards, with a consequent expansion of upper and lower comfort limits, can lead to higher energy savings	[110]

### 3.4. Papers Not Linked to a Specific Environment Type (Various, Unspecified, . . . )

This subsection comprises the articles which do not refer to a specific type of environment. This is due to two main reasons: 1. articles (mainly reviews) referred to all the types of environments in general; 2. studies referred to general mock-ups or models. Consequently, seven papers among the ones in this subsection are literature reviews, constituting the majority of all the reviews considered in the present work. The rest of the articles here explored are journal papers (6). No conference papers are present in this subsection. Similarly, several studies (7) were not linkable to a specific continent, country, or climate. Among the others, four studies were related with Asia, one with Europe, and one was referred to tropical climate in general. Twelve articles out of thirteen considered the thermo-hygrometric domain. The domain was again followed by IAQ (9), acoustic and visual (5 each), and multi-domain (2). Moreover, also in this case, the thermo-hygrometric domain was mostly linked with ventilation for thermal regulation and IAQ was mostly linked with air change. Similarly to residential and non-residential sections, night cooling, when considered, was mainly named or implied (e.g., as ventilation performed at night). Brief summaries of the main results are reported in Table 3, while Table S3 (Supplementary Materials) contains further and specific details about the articles considered in this subsection.

Table 3. Key findings related with various or unspecified environments.

Thermo-Hygrometric Comfort	
Main Findings	References
NV can sometimes be inapplicable due to extreme conditions (temperature or running air)	[128]
In hot and humid climates (such as Malaysian) MV can be advantageous on the thermal comfort point of view	[129]
Well-designed NV is often adequate to maintain acceptable indoor thermo-hygrometric conditions	[130–134]
Wider ranges of thermal comfort are present in hot, humid climates, than what is generally indicated in international standard	[131]
Cooling from MV should be used only when adequate thermal comfort conditions cannot be guaranteed	[65]
Ventilation energy can be reduced only if comfort of occupants can be guaranteed	[31]
Importance of well-designed ventilation to guarantee occupants' comfort	[130,135]
Numerical models can be useful for control strategies	[133]
Visual comfort	

Table 3. Cont.

<b>Thermo-Hygrometric Comfort</b>		
	<b>Main findings</b>	<b>References</b>
	Similar constructive techniques such as atriums, double skin façades, and apertures can be exploited for both NV and daylight	[31,132]
	Used together with the other comfort domains to categorize the studies considered in the review	[136]
<b>IAQ</b>		
	<b>Main findings</b>	<b>References</b>
	Even though NV is the cheapest and most often used environmental disinfection method against airborne transmittable diseases, proper disinfection is provided by MV	[128]
	Higher morbidity cases (13–38% increase) and mortality (28% increase) related with NV adoption in residential buildings of Singapore; adoption of technologies such as MV and filtration from current NV in schools would diminish the number of asthma cases; mortality would also be decreased by the use of filtration in workplaces	[137]
	Importance of taking into account occupants' behavior and pollutions' sources in ventilation design	[31,130,138]
<b>Acoustic comfort</b>		
	<b>Main findings</b>	<b>References</b>
	Noise is one of the parameters affecting occupants' behavior. Atriums and double-skin façades can be used to exploit NV, while protecting from noise	[31]
	Importance of considering outdoor noise when designing ventilation	[130,133]
	Used for categorization or marginally considered	[136,138]
<b>Multi-domain</b>		
	<b>Main findings</b>	<b>References</b>
	Elements such as daylight availability (heat-load related), thermal mass, and night ventilation (cooling load related) are essential for thermal comfort	[138]
	Thermal perception is also influenced by healthy IAQ	[131]
<b>Energy consumption and other issues</b>		
	<b>Main findings</b>	<b>References</b>
	Energy savings are associated with passive cooling and NV	[65,128,130,132]
	Necessity of coupling ventilation techniques with other passive strategies, with the aim of decreasing the carbon footprint of buildings	[131]
	Climatic design for passive cooling, use of orientation and materials (e.g., for night cooling) and proper MV operations are fundamental for ventilation design	[130]
	Necessity of studies on vernacular apertures and elements, as well as louvered windows to exploit night cooling, in order to maximize NV efficiency in tropical climate	[132]
	Importance of more studies in the field of balconies' design, as well as post-occupancy evaluations, for NV optimization	[136]
	Remarkable energy savings can be obtained by means of HV: more studies on smart window based HV should be made	[31]
	Ventilation of unoccupied or low-occupied spaces leads to a significant amount of wasted energy	[31]
	A combination of mechanical and passive cooling and different control strategies can lead to a reduction of more than the 60% of the system size and associated energy used	[65]
	Use of models and simulations applied and encouraged in design and evaluation	[129,130,133,134]

### 3.5. Final Statistics

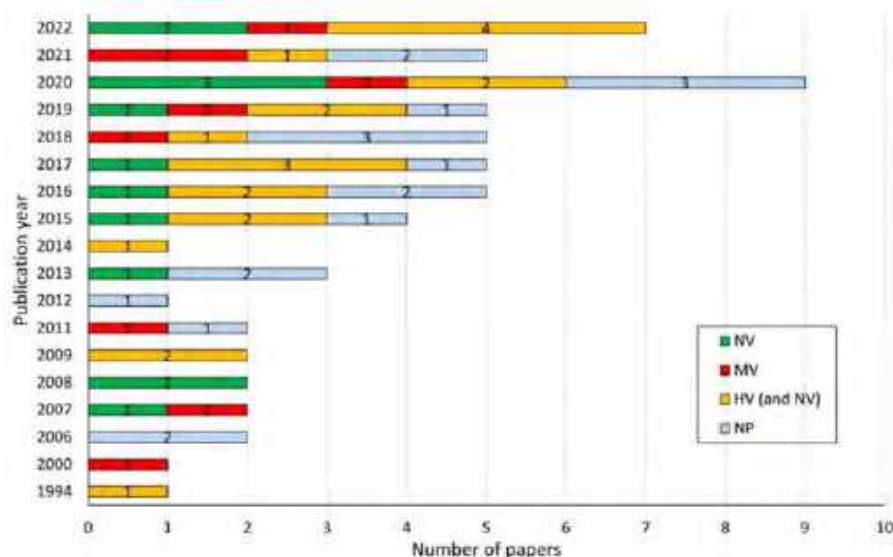
Table 4, on the left, reports the number of papers suggesting specific ventilation types. Nineteen papers do not express a clear suggestion between MV, NV, and HV. Among the rest of the papers, a relative similar share suggest NV (13) and MV (9), while most

studies (21) recommend the use of HV in order to guarantee energy savings with backup mechanical systems when IEQ conditions cannot be maintained by passive techniques only. It is fundamental to stress that papers recommending HV normally suggest it when satisfactory indoor conditions cannot be reached with NV alone. For this reason, it was decided to group together papers recommending HV and both HV and NV, as “HV (and NV)”. In the same table, on the right, the number of papers treating each comfort domain is reported. As previously implied, thermo-hygrometric is the mostly explored domain (56 papers), followed by IAQ (40), acoustic (21), and visual (12). Only six papers consider or name the importance of a multi-domain approach.

**Table 4.** Number of studies suggesting each ventilation type and number of studies treating each comfort domain. NV: natural ventilation; MV: mechanical ventilation; HV: hybrid ventilation; NP: no preference. T.H.: thermo-hygrometric; Vis.: =visual; IAQ: indoor air quality; Ac.: acoustic; M.Do.: multi-domain.

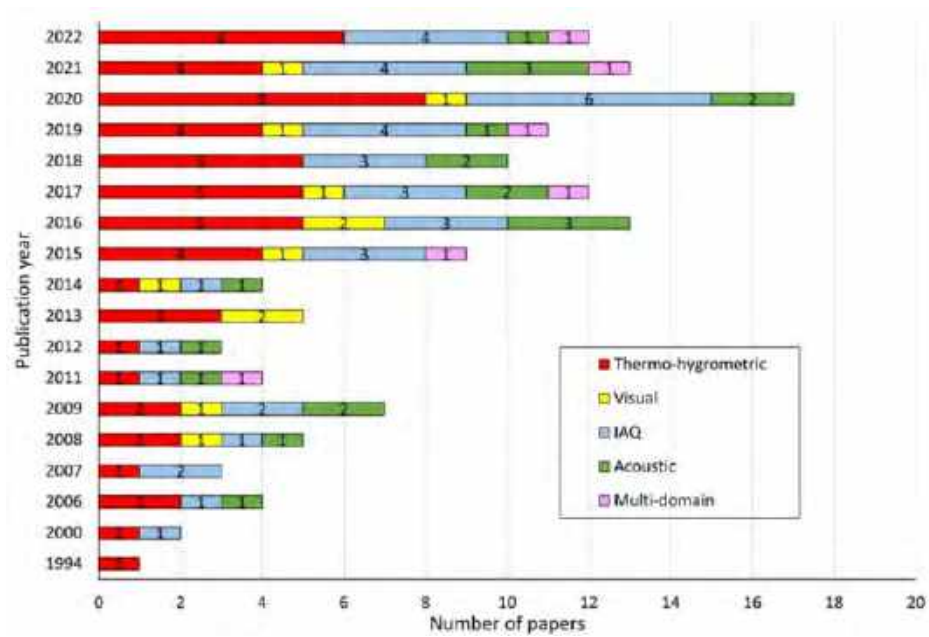
	Ventilation Type Suggested				Comfort Domain Treated				
	NV	MV	HV (and NV)	NP	T.H.	Vis.	IAQ	Ac.	M.Do.
<b>N. of papers</b>	13	9	21	19	56	12	40	21	6

Figure 5 allows to explore the association between the publication year and the type of ventilation recommended. It is interesting to notice how the share of papers recommending NV or HV (and NV) seem to slightly increase in time, probably in relation with energy efficiency issues. This trend seems to interrupt in 2021, most likely due to the pandemic, causing more research to suggest the use of MV for health reasons and contrast of virus transmission.



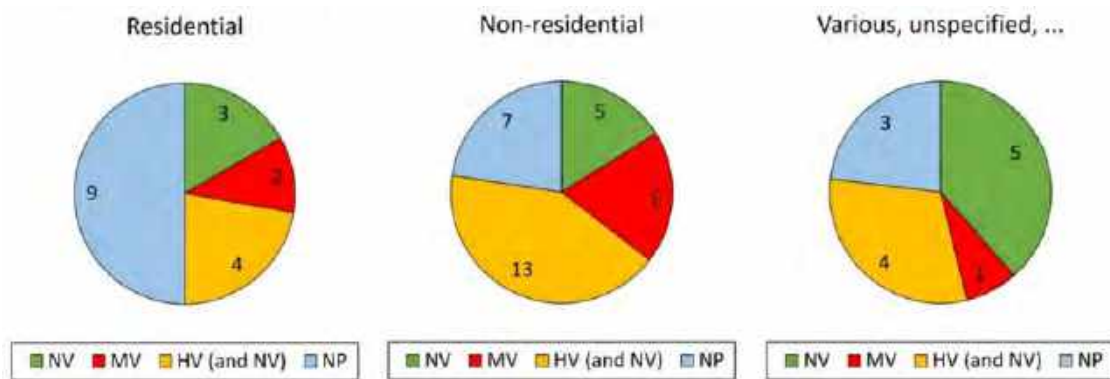
**Figure 5.** Association between ventilation type suggested and publication year. Numbers indicate the number of papers recommending each ventilation type. NV: natural ventilation; MV: mechanical ventilation; HV: hybrid ventilation; NP: no preference.

Similarly, Figure 6 shows association of comfort domain treated and year of publication. The share of domains considered does not seem to be correlated with the publication year. Nevertheless, as previous subparagraphs underline, visual and acoustic domain are mainly treated marginally, especially in older publications. New publications, instead, more often link these two domains with the multi-domain approach, which is actually more frequent in recent years. Nevertheless, the approach is mainly suggested without performing complete studies about it.



**Figure 6.** Association between comfort domain treated and publication year. Numbers indicate the number of papers considering each comfort domain.

The number of papers for each building category is reported in Table 5. Eighteen papers refer to residential environments. On the other hand, thirteen studies are not linked with any specific environment (e.g., laboratory studies) or are referred to various types of buildings (typically reviews). The majority of papers (31) regard non-residential environments. The highest share of these refer to educational (schools or universities) facilities (12) or working (office) facilities (14). The rest regard industrial (1), amusement (1) or non-residential buildings in general (2). Only one paper related with healthcare facilities was found. The details about the type of ventilation recommended depending on the building type are reported in Figure 7. It is clear that the share of articles suggesting MV or HV is higher in non-residential buildings.



**Figure 7.** Type of ventilation suggested depending on building type. Numbers indicate the number of papers recommending each ventilation type. NV: natural ventilation; MV: mechanical ventilation; HV: hybrid ventilation; NP: no preference.

**Table 5.** Number of studies per building type. Res.: residential; Non-res.: non-residential; Var.: Various/Inapplicable; Edu.: educational; Hea.: healthcare; Wor.: working; Ind.: industrial; Amu.: amusement; Gen.: non-residential in general.

	Res.	Non-Res.						Var.	
		TOT	Edu.	Hea.	Wor.	Ind.	Amu.		Gen.
N. of papers	18	31	12	1	14	1	1	2	13

#### 4. Discussions

The present literature review focuses on the comparison of IEQ conditions provided by natural ventilation (NV) and mechanical ventilation (MV), with the aim of collecting and offering a framework of scientific evidence to be exploited for sustainable design (e.g., nZEB, nPEB, and climate-responsive architecture). For this reason, the comparison of energy consumption by the two ventilation types was also highlighted, when present in the literature analyzed. When present in the analyzed articles, benefits of HV were also stressed.

The study permitted to highlight the following main considerations:

1. The articles comparing NV and MV in terms of indoor comfort and well-being found in literature are not very numerous. Moreover, even though current research is moving to the concept of well-being, this aspect is not explored in the studies included in the present review, as related keywords never appear in the articles analyzed. Most of the papers found regard non-residential facilities, in particular educational and working environments, underlining the key role of ventilation for obtaining healthy and comfortable conditions in highly occupied premises. Surprisingly, only one paper related to healthcare facilities was found. Several papers highlighting the performance of either MV or NV in healthcare facilities are present in the literature, but the comparison between comfort and well-being provided by NV and MV in this type of building is mainly under-explored. This is probably due to the specific field the present review is related with: studies about ventilation in hospitals that mainly deal with sanitation reasons; therefore, the comparison between the ventilation techniques mainly regards that topic instead of indoor comfort. The association between the number of studies and the publication year has been growing in time, with a sudden increase during 2020, due to the COVID-19 pandemic. The highest amount of papers was related to case studies located in Europe and Asia, highlighting a need for more research in other areas of the world. Most papers explored thermo-hygrometric and IAQ domains. When present, other domains were mainly considered only marginally, for instance stating that a relation between them and ventilation (e.g., noise) is present, and that further research in the field is necessary. During the most recent years, some articles highlighting the importance of multi-domain research appeared. Nevertheless, the topic has not been deeply explored yet.
2. Thermal comfort was the most frequently explored domain in all the types of environments. In all cases, contrasting conclusions on whether MV or NV is preferable were drawn. Confirming what previously found in the literature, the main advantage of MV was recognized to be the ability to precisely set the indoor conditions. Nevertheless, this is not frequently perceived by occupants, who often prefer NV due to a higher degree of control over the environment they occupy and a major air movement, underlining the influence of the sensation of accessing to the outside. In this sense, the thermal environment was observed to be the main driver of occupants' NV behavior, with outdoor temperature (due to climate or season) being the main parameter affecting windows opening. Moreover, a shift in the usage of NV might be observed due to climate change, with the hours of windows opening potentially decreasing at warmer climates, but increasing at mild or colder ones. Furthermore, some articles highlight the presence of wider comfort ranges in warmer and/or developing



countries. This is probably due to reasons dealing with adaptation. The necessity of proper ventilation design to ensure the right indoor thermo-hygrometric conditions without creating local discomfort (such as draught) was stressed by several papers. In this sense, a more local focus, instead of the reference to international standards and the integration of other passive or active technologies such as night cooling or heat recovery, was promoted. No remarkable differences in findings were found among the different environment types.

3. After thermo-hygrometric, IAQ was the second most explored domain by the papers considered. Especially in residential environments, air tightness of refurbished buildings was seen as an issue for IAQ conditions and proper ventilation design. Particularly in non-residential buildings, MV was often associated with better air quality and less CO<sub>2</sub> and particles concentration. Type of ventilation must be carefully chosen depending on several conditions comprising outdoor pollution. In non-residential facilities in particular, a sudden change in perspective was observed after 2020, with a more health-driven vision of ventilation, strongly focused on the stop of airborne transmission of pathogens.
4. Visual and acoustic comfort were mainly explored marginally, as well as multi-domain approach. For instance, some recent works named visual and acoustic domains highlighting that their connection with ventilation, thermo-hygrometric, and IAQ conditions are important for future research, with a multi-domain point of view. Some papers highlighted how daylight and NV often benefit of the same constructive and architectural characteristics, such as high windows or operable skylights. Acoustic comfort was often explored in terms of noise, seen as an issue for the application of NV (when noise from the outside is present) or MV (poorly designed plants). Nevertheless, the effect of outside pleasant sounds or the so called “adaptive acoustic comfort” needs to be further studied and explored.
5. A high number of papers highlighted how energy consumption is the main disadvantage in the use of MV. On the other hand, NV might be too dependent on occupants’ behavior and might lead to a loss of energy at colder or warmer conditions. Most papers, especially when dealing with extreme climates or larger and commercial buildings, proposed HV as a solution. This technique allows to lower the carbon footprint of buildings, while ensuring sufficient air change when proper indoor conditions cannot be met with passive solutions. The higher share of papers suggesting MV or HV in non-residential buildings is due to the fact that these facilities are constituted by environments which are normally studied for a higher number of occupants (i.e., schools, offices). For this reason, automated or semi-automated systems seem to be more adequate to guarantee the right amount of fresh air in these facilities. In order to improve the ventilation efficiency and the energy savings, the use of advanced technologies (e.g., heat recovery or energy storage) and proper and careful ventilation design were often promoted. For instance, focus should be placed on the optimal velocity of the exhaust in order to obtain the maximization of energy and ventilation efficiency without creating supply exhaust short-circuiting. In this sense, the use of CFD simulations was encouraged, helping with architectural characteristics improving NV, such as building orientation and position, façades, size, and location of inlets and outlets. Finally, a change in standards and guidelines was suggested by some authors in order to improve energy consumption and energy savings, for instance encouraging NV when possible.

## 5. Conclusions

Even though ventilation design is often aimed at ensuring adequate IAQ, thermo-hygrometric comfort seems to be the main ventilation behavior driver for occupants. Especially in non-residential buildings and after the COVID-19 pandemic, the approach in ventilation studies has slightly changed to a health-based driven, rather than a comfort- or energy-based one. In general, present research strongly highlights that hybrid ventilation

is the most recommended solution in order to guarantee both energy savings and proper IEQ conditions when not achievable with natural ventilation alone. This is particularly true in extreme or polluted climates, where window openings alone can lead to poor indoor conditions, and/or highly occupied or healthcare environments, where NV alone might not be sufficient to maintain an adequate level of IAQ and healthy conditions. The literature analyzed also suggests that, when possible (e.g., residential environments and smaller offices) the hybrid solutions should also consider the necessity of control by occupants, allowing to switch to a total manual system if required. Proper design of ventilation is encouraged, promoting the use of numerical modelling such as CFD analyses, in order to ensure IEQ and avoid issues such as short-circuiting of supply and exhaust air and draught sensation by occupants. From present literature, it was highlighted how some topics remain under-explored. The current tendency in indoor climate studies is to move from the concept of comfort to a more holistic well-being one, considering aspects related with comfort, satisfaction, health, and well-functioning. Nevertheless, the concept of well-being was not explored in the literature here analyzed. Moreover, only marginal attention was provided to visual, acoustic, and multi-domain comfort. Other under-explored topics regard passive technologies such as night cooling, as well as some types of environments such as healthcare facilities.

## 6. Future Developments

Ventilation is a key factor in the field of sustainable design, specifically regarding nZEB, nPEB, and climate-responsive design, as energy savings strongly depend on ventilation techniques. In this framework, the choice of proper ventilation type (to be energy-driven or IEQ-driven) cannot be made regardless of indoor comfort and well-being. The use of either NV, MV, or HV is highly dependent on the climate, the outside pollution, the building type, and the season. In this sense, the ventilation system should be coupled with sensors and smart home solutions, being able to switch from one typology to another whenever the indoor and outdoor conditions allow or require it. Moreover, warning sensors might be useful to advise occupants on the indoor pollutants and CO<sub>2</sub> concentration when NV is used.

Studies addressing the topic of well-being related with the comparison of NV and MV are beneficial for human-centered indoor building design. Moreover, the literature, standards, and guidelines would benefit from studies on ventilation exploring comfort with a multi-domain perspective. Ventilation is clearly and directly connected with thermo-hygrometric environment and IAQ, but recent studies agree on how all the comfort aspects interact (e.g., noise-IAQ, emissions of pollutants with higher sunlight, psychological aspects). For this reason, comfort studies coupling subjective surveys with objective measurements, and correlating the comfort perception in terms of the four domains with each other would be necessary. Moreover, some environments such as healthcare facilities need further research in terms of comfort related with comparison of different ventilation techniques. Ventilation studies might be mostly health-driven in these environments, but a significant amount of previous literature underline the relationship between healing processes and indoor well-being [52,139–141]: therefore, this aspect cannot be neglected.

The exploitation of night cooling allows to further exploit natural ventilation during nighttime, when lower temperatures are present, using the delay in the heating process of massive elements. Therefore, comparative comfort studies with and without this technique would allow to assess the comfort benefits during morning hours, further encouraging designers and stakeholders to exploit this technique. Other innovative passive solutions have been proposed in the last years, including the use of internal cladding for improving the thermal inertia, the coupling of massive elements with the smart use of shadings, use of compact form to reduce the heat loss through the envelope area, organization of spaces (e.g., non-habitable areas on eastern and western sides to act as additional thermal buffers, living rooms towards south to better exploit solar gains, etc.), air quality control through proper selection of materials in air-tight buildings, etc. [34,35,97,142–153]. The use of these

techniques should be explored in terms of indoor well-being when coupled with MV and NV systems.

## 7. Limitations

The present paper aims at providing an overview on the comparison of IEQ conditions provided by different ventilation types. For this reason, it was chosen to include only papers comprising and treating both the types of ventilation, in order to highlight the points in common and differences in the indoor conditions and energy savings provided by each ventilation technique. For this reason, the research can be expanded considering the two ventilation types separately. Moreover, as it is common in review processes, the final papers analyzed depend on the search query, the inclusion criteria, and the database considered.

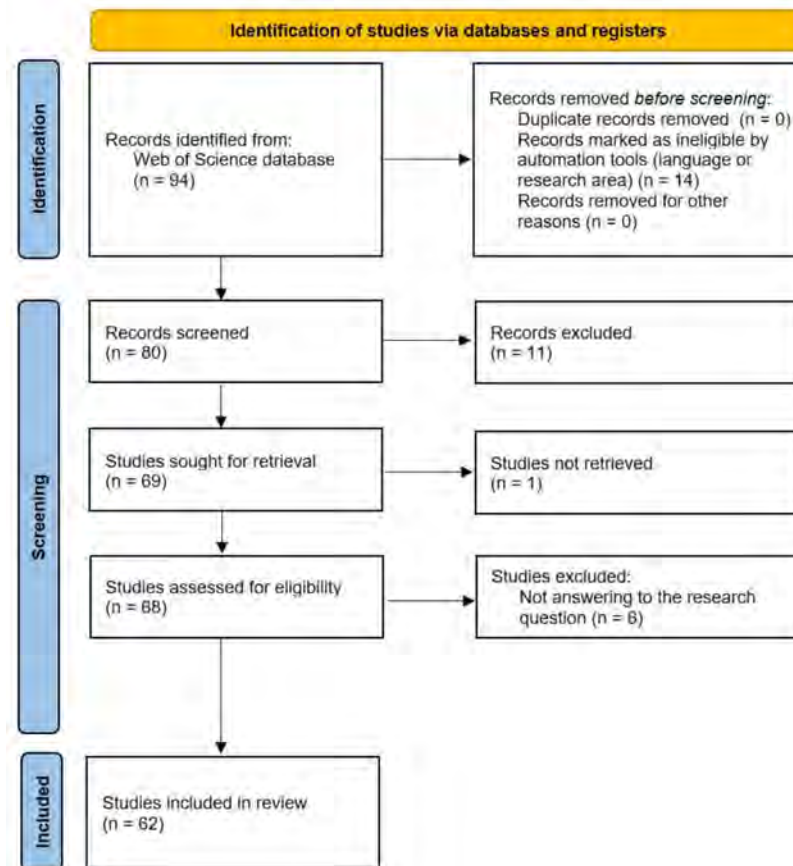
**Supplementary Materials:** The following supporting information can be downloaded at: <https://www.mdpi.com/article/10.3390/buildings12111983/s1>. Table S1. Studies related with residential environments: summary of key data, comfort domain treated, approach, main conclusions and type of ventilation recommended. JP = journal paper; R = review; CP = conference paper. A.Ch. = air-change; T.R. = thermal regulation; N.C. = night cooling. "T.H." = thermo-hygrometric; "Vis." = visual; "IAQ" = indoor air quality; "Ac." = acoustic; "M.Do." = multi-domain. NV = natural ventilation; MV = mechanical ventilation; HV = hybrid ventilation; NP = no preference. "Env." = environment; "Vent. Rec." = ventilation recommended; "Res." = residential. T = temperature; RH = Relative Humidity; ACR=air-change rate. Table S2. Studies related with non-residential environments: summary of key data, comfort domain treated, approach, main conclusions and type of ventilation recommended. JP = journal paper; R = review; CP = conference paper. A.Ch. = air-change; T.R. = thermal regulation; N.C. = night cooling. "T.H." = thermo-hygrometric; "Vis." =visual; "IAQ" = indoor air quality; "Ac." = acoustic; "M.Do." = multi-domain. NV = natural ventilation; MV = mechanical ventilation; HV = hybrid ventilation; NP = no preference. "Env." = environment; "Vent. Rec." = ventilation recommended; "Edu." = educational; "Hea." = healthcare; "Wor." = working; "Ind." = industrial; "Amu." = amusement; "Gen." = non-residential in general. T = temperature; RH = Relative Humidity; ACR=air-change rate. Table S3. Studies not related with a specific type of environment: summary of key data, comfort domain treated, approach, main conclusions and type of ventilation recommended. JP = journal paper; R = review; CP = conference paper. A.Ch. = air-change; T.R. = thermal regulation; N.C. = night cooling. "T.H." = thermo-hygrometric; "Vis." =visual; "IAQ" = indoor air quality; "Ac." = acoustic; "M.Do." = multi-domain. NV = natural ventilation; MV = mechanical ventilation; HV = hybrid ventilation; NP = no preference. "Env." = environment; "Vent. Rec." = ventilation recommended; "Var." = Various/Inapplicable. T = temperature; RH = Relative Humidity; ACR = air-change rate.

**Author Contributions:** Conceptualization, L.Z. and R.A.; Methodology: L.Z. and R.A.; Formal Analysis: L.Z.; Investigation: L.Z.; Resources: R.A.; Data curation and data interpretation: L.Z.; Writing—Original Draft Preparation: L.Z.; Writing—Review and Editing: L.Z. and R.A.; Visualization: L.Z.; Supervision: R.A.; Project Administration: R.A.; Funding Acquisition: R.A. All authors have read and agreed to the published version of the manuscript.

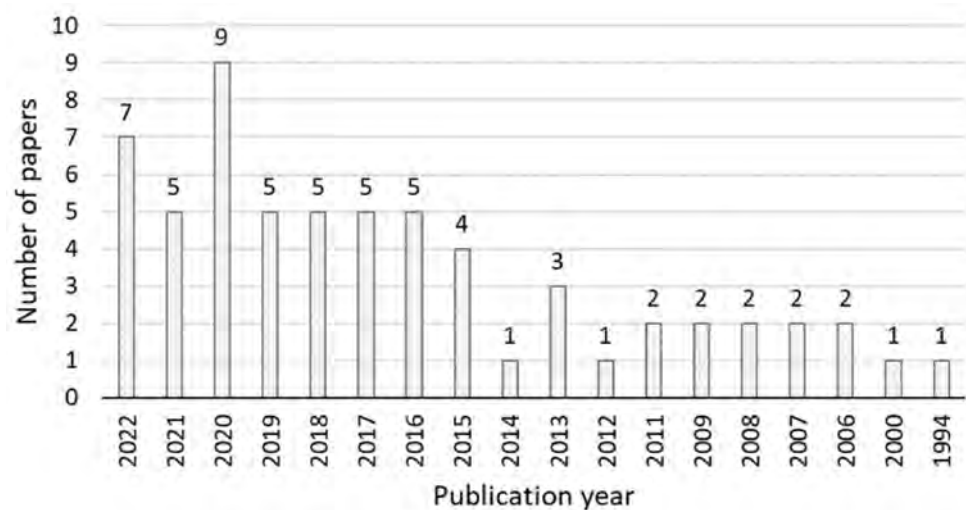
**Funding:** The research received support from the project "Climate Positive Circular Communities"—"ARV" funded within the European Union's Horizon 2020 Research and Innovation Programme, agreement No. 101036723.

**Conflicts of Interest:** The authors declare no conflict of interest. The funders had no role in the design of the study; in the collection, analyses, or interpretation of data; in the writing of the manuscript; or in the decision to publish the results.

## Appendix A



**Figure A1.** PRISMA flowchart depicting the inclusion/exclusion and screening process. Adapted with permission from PRISMA Website [82].



**Figure A2.** Papers found for each publication year.

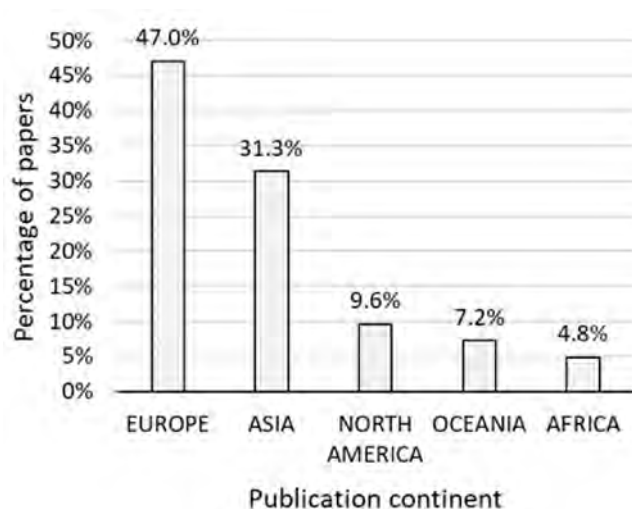


Figure A3. Percentage of papers produced in each continent.

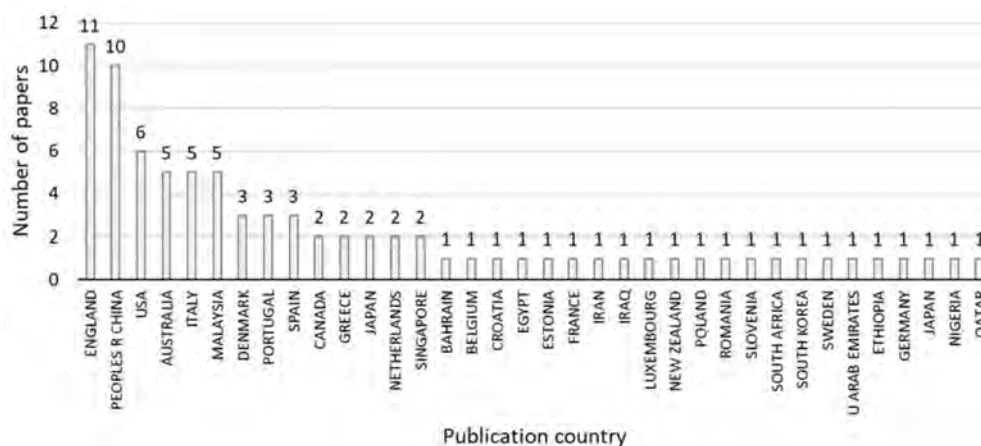


Figure A4. Papers found for each country/region.

## References

1. In Focus: Energy Efficiency in Buildings. Available online: [https://ec.europa.eu/info/news/focus-energy-efficiency-buildings-2020-lut-17\\_en](https://ec.europa.eu/info/news/focus-energy-efficiency-buildings-2020-lut-17_en) (accessed on 14 June 2022).
2. Torcellini, P.; Pless, S.; Deru, M.; Crawley, D. *Zero Energy Buildings: A Critical Look at the Definition*; National Renewable Energy Lab.: Golden, CO, USA, 2006; p. 13.
3. U.S. Department of Energy. *A Common Definition for Zero Energy Buildings*; U.S. Department of Energy: Washington, DC, USA, 2015. Available online: <https://www.energy.gov/sites/prod/files/2015/09/f26/A%20Common%20Definition%20for%20Zero%20Energy%20Buildings.pdf> (accessed on 3 June 2022).
4. Magrini, A.; Lentini, G.; Cuman, S.; Bodrato, A.; Marengo, L. From nearly zero energy buildings (NZEB) to positive energy buildings (PEB): The next challenge—The most recent European trends with some notes on the energy analysis of a forerunner PEB example. *Dev. Built Environ.* **2020**, *3*, 100019. [CrossRef]
5. Hu, M. Net-positive building and alternative energy in an institutional environment. In *ACEEE Summer Study on Energy Efficiency in Buildings*; American Council for an Energy-Efficient Economy: Washington, DC, USA, 2016; pp. 10–12. Available online: [https://www.aceee.org/files/proceedings/2016/data/papers/10\\_80.pdf](https://www.aceee.org/files/proceedings/2016/data/papers/10_80.pdf) (accessed on 3 June 2022).
6. Sterk, T. Thoughts for Gen X—Speculating about the rise of continuous measurement in architecture’ in Sterk, Loveridge, Pancoast “Building A Better Tomorrow”. In *Building A Better Tomorrow, Proceedings of the 29th Annual Conference of the Association of Computer Aided Design in Architecture, Chicago, IL, USA, 22–25 October 2009*; Loveridge, S., Pancoast, D., Eds.; The Art Institute of Chicago: Chicago, IL, USA, 2009.
7. Negroponte, N. *Soft Architecture Machines*; MIT Press: Cambridge, MA, USA, 1975.
8. Bullivant, L. *Responsive Environments: Architecture, Art and Design (V&A Contemporary)*; Victoria and Albert Museum: London, UK, 2006.
9. Bullivant, L. *4dspace: Interactive Architecture*; AD/John Wiley & Sons: London, UK, 2005.
10. Bullivant, L. *4dsocial: Interactive Design Environments*; AD/John Wiley & Sons: London, UK, 2007.



11. Beesley, P.; Hirose, S.; Ruxton, J.; Trankle, M.; Turner, C. *Responsive Architectures: Subtle Technologies*; Riverside Architectural Press: Cambridge, ON, USA, 2006.
12. Designing for Typologies: 15 Examples of Climate Responsive Buildings around the World. Available online: <https://www.re-thinkingthefuture.com/designing-for-typologies/> (accessed on 19 May 2022).
13. Hanc, M.; McAndrew, C.; Ucci, M. Conceptual approaches to wellbeing in buildings: A scoping review. *Build. Res. Inf.* **2019**, *47*, 767–783. [[CrossRef](#)]
14. Ruggeri, K.; Garcia-Garzon, E.; Maguire, Á.; Matz, S.; Huppert, F.A. Well-being is more than happiness and life satisfaction: A multidimensional analysis of 21 countries. *Health Qual. Life Outcomes* **2020**, *18*, 192. [[CrossRef](#)] [[PubMed](#)]
15. *UNI EN 15251:2007*; Indoor Environmental Input Parameters for Design and Assessment of Energy Performance of Buildings Addressing Indoor Air Quality, Thermal Environment, Lighting and Acoustics. Comité'Europe'en de Normalisation: Brussels, Belgium, 2007.
16. *UNI EN ISO 16798-1:2019*; Energy Performance of Buildings—Part 1: Indoor Environmental Input Parameters For Design and Assessment of Energy Performance of Buildings Addressing Indoor Air Quality, Thermal Environment, Lighting and Acoustics. Comité'Europe'en de Normalisation: Brussels, Belgium, 2019.
17. Toftum, J. Human response to combined indoor environment exposures. *Energy Build.* **2002**, *34*, 601–606. [[CrossRef](#)]
18. Torresin, S.; Pernigotto, G.; Cappelletti, F.; Gasparella, A. Combined effects of environmental factors on human perception and objective performance: A review of experimental laboratory works. *Indoor Air* **2018**, *28*, 525–538. [[CrossRef](#)]
19. Schweiker, M.; Ampatzi, E.; Andargie, M.S.; Andersen, R.K.; Azar, E.; Barthelmes, V.M.; Berger, C.; Bourikas, L.; Carlucci, S.; Chinazzo, G.; et al. Review of multi-domain approaches to indoor environmental perception and behaviour. *Build. Environ.* **2020**, *176*, 106804. [[CrossRef](#)]
20. Aries, M.B.C.; Veitch, J.A.; Newsham, G.R. Windows, view, and office characteristics predict physical and psychological discomfort. *J. Environ. Psychol.* **2010**, *30*, 533–541. [[CrossRef](#)]
21. Kubba, S. *Handbook of Green Building Design and Construction: LEED, BREEAM, and Green Globes*; Butterworth-Heinemann: Oxford, UK, 2012.
22. Azar, E.; O'Brien, W.; Carlucci, S.; Hong, T.; Sonta, A.; Kim, J.; Andargie, M.S.; Abuimara, T.; El Asmar, M.; Jain, R.K.; et al. Simulation-aided occupant-centric building design: A critical review of tools, methods, and applications. *Energy Build.* **2020**, *224*, 110292. [[CrossRef](#)]
23. Olesen, B.W.; Bluyssen, P.; Roulet, C.-A. Ventilation and Indoor Environmental Quality. In *Ventilation Systems—Design and Performance*; Awbi, H.B., Ed.; Taylor & Francis: London, UK, 2008.
24. WHO. *Indoor Air Quality Research*; World Health Organization: Copenhagen, Denmark, 1986.
25. Wolkoff, P.; Azuma, K.; Carrer, P. Health, work performance, and risk of infection in office-like environments: The role of indoor temperature, air humidity, and ventilation. *Int. J. Hyg. Environ. Health* **2021**, *233*, 113709. [[CrossRef](#)]
26. Bekö, G.; Weschler, C.J.; Langer, S.; Callesen, M.; Toftum, J.; Clausen, G. Children's Phthalate Intakes and Resultant Cumulative Exposures Estimated from Urine Compared with Estimates from Dust Ingestion, Inhalation and Dermal Absorption in Their Homes and Daycare Centers. *PLoS ONE* **2013**, *8*, e62442. [[CrossRef](#)]
27. Wargocki, P.; Wyon, D.P.; Baik, Y.K.; Clausen, G.; Fanger, P.O. Perceived Air Quality, Sick Building Syndrome (SBS) Symptoms and Productivity in an Office with Two Different Pollution Loads. *Indoor Air* **1999**, *9*, 165–179. [[CrossRef](#)] [[PubMed](#)]
28. Wargocki, P.; Wyon, D.P.; Sundell, J.; Clausen, G.; Fanger, P.O. The Effects of Outdoor Air Supply Rate in an Office on Perceived Air Quality, Sick Building Syndrome (SBS) Symptoms and Productivity: Effects of Outdoor Air Supply Rate. *Indoor Air* **2000**, *10*, 222–236. [[CrossRef](#)] [[PubMed](#)]
29. Salcido, J.C.; Raheem, A.A.; Issa, R.R.A. From simulation to monitoring: Evaluating the potential of mixed-mode ventilation (MMV) systems for integrating natural ventilation in office buildings through a comprehensive literature review. *Energy Build.* **2016**, *127*, 1008–1018. [[CrossRef](#)]
30. Carrilho da Graça, G.; Linden, P. Ten questions about natural ventilation of non-domestic buildings. *Build. Environ.* **2016**, *107*, 263–273. [[CrossRef](#)]
31. Chenari, B.; Dias Carrilho, J.; Gameiro da Silva, M. Towards sustainable, energy-efficient and healthy ventilation strategies in buildings: A review. *Renew. Sustain. Energy Rev.* **2016**, *59*, 1426–1447. [[CrossRef](#)]
32. Givoni, B. Effectiveness of mass and night ventilation in lowering the indoor daytime temperatures. Part I: 1993 experimental periods. *Energy Build.* **1998**, *28*, 25–32. [[CrossRef](#)]
33. Shaviv, E.; Yezioro, A.; Capeluto, I.G. Thermal mass and night ventilation as passive cooling design strategy. *Renew. Energy* **2001**, *24*, 445–452. [[CrossRef](#)]
34. Nikoofard, S.; Ugursal, V.I.; Beausoleil-Morrison, I. Effect of external shading on household energy requirement for heating and cooling in Canada. *Energy Build.* **2011**, *43*, 1627–1635. [[CrossRef](#)]
35. Zaniboni, L.; Pernigotto, G.; Gasparella, A. Analysis of two shading systems in a glazed-wall physiotherapy center in Bolzano, Italy. In Proceedings of the BSA Conference 2019: Fourth Conference of IBPSA-Italy, Rome, Italy, 2–4 September 2019; pp. 77–84.
36. Krarti, M. Integrated design and retrofit of buildings. In *Optimal Design and Retrofit of Energy Efficient Buildings, Communities, and Urban Centers*; Elsevier: Amsterdam, The Netherlands, 2018; pp. 313–384. [[CrossRef](#)]
37. Passe, U.; Battaglia, F. *Designing Spaces for Natural Ventilation—An Architect's Guide*; Routledge: London, UK, 2015.

38. CIBSE. *TM40: Health and Wellbeing in Building Services*; Chartered Institution of Building Services Engineers (CIBSE): London, UK, 2019. Available online: <https://www.cibse.org/Knowledge/CIBSETM/TM40-2019-Health-Issues-and-Wellbeing-in-Building-Services#Exec%20summary> (accessed on 4 April 2022).
39. Alvarez, S.; Dascalaki, E.; Guarracino, G.; Maldonado, E.; Sciuto, S.; Vandaele, L. *Natural Ventilation in Buildings. A Design Handbook*; James & James: Northampton, UK, 1998.
40. Etheridge, D. *Natural Ventilation of Buildings: Theory, Measurement and Design*; John Wiley & Sons: Hoboken, NJ, USA, 2011.
41. De Dear, R.J.; Brager, G.S. Thermal comfort in naturally ventilated buildings: Revisions to ASHRAE Standard 55. *Energy Build.* **2002**, *34*, 549–561. [[CrossRef](#)]
42. De Dear, R.; Schiller Brager, G. The adaptive model of thermal comfort and energy conservation in the built environment. *Int. J. Biometeorol.* **2001**, *45*, 100–108. [[CrossRef](#)]
43. De Dear, R.; Brager, G. *Developing an Adaptive Model of Thermal Comfort and Preference*; Center for the Built Environment: Berkeley, CA, USA, 1998. Available online: <https://www.semanticscholar.org/paper/Developing-an-adaptive-model-of-thermal-comfort-and-Deear-Brager/aba60223bb4216c3d145886f385a3a019d1c86c4> (accessed on 6 June 2022).
44. ANSI/ASHRAE Standard 55: 2017; Thermal Environmental Conditions for Human Occupancy. ASHRAE: Atlanta, GA, USA, 2017.
45. Fanger, P.O. *Thermal Comfort. Analysis and Applications in Environmental Engineering*; Danish Technical Press: Copenhagen, Denmark, 1970.
46. Seppänen, O.; Fisk, W.J. Association of ventilation system type with SBS symptoms in office workers: SBS symptoms in office workers. *Indoor Air* **2002**, *12*, 98–112. [[CrossRef](#)] [[PubMed](#)]
47. Ronold, A. Chapter 17—Ventilation. In *Computational Wind Engineering 1*; Elsevier: Amsterdam, The Netherlands, 1993.
48. Torresin, S.; Albatici, R.; Aletta, F.; Babich, F.; Oberman, T.; Stawinoga, A.E.; Kang, J. Indoor soundscapes at home during the COVID-19 lockdown in London—Part I: Associations between the perception of the acoustic environment, occupant's activity and well-being. *Appl. Acoust.* **2021**, *183*, 108305. [[CrossRef](#)]
49. Torresin, S.; Albatici, R.; Aletta, F.; Babich, F.; Oberman, T.; Stawinoga, A.E.; Kang, J. Indoor soundscapes at home during the COVID-19 lockdown in London—Part II: A structural equation model for comfort, content, and well-being. *Appl. Acoust.* **2022**, *185*, 108379. [[CrossRef](#)]
50. Olgyay, V. *Design with Climate: Bioclimatic Approach to Architectural Regionalism*; Princeton University Press: Princeton, NJ, USA, 1963.
51. Ryan, C.O.; Browning, W.D.; Clancy, J.O.; Andrews, S.L.; Kallianpurkar, N.B. BIOPHILIC DESIGN PATTERNS: Emerging Nature-Based Parameters for Health and Well-Being in the Built Environment. *Int. J. Archit. Res. ArchNet-IJAR* **2014**, *8*, 62. [[CrossRef](#)]
52. Ulrich, R.S. View Through a Window May Influence Recovery from Surgery. *Science* **1984**, *224*, 420–421. [[CrossRef](#)] [[PubMed](#)]
53. Hähn, N.; Essah, E.; Blanusa, T. Biophilic design and office planting: A case study of effects on perceived health, well-being and performance metrics in the workplace. *Intell. Build. Int.* **2021**, *13*, 241–260. [[CrossRef](#)]
54. Altomonte, S.; Allen, J.; Bluysen, P.; Brager, G.; Hescong, L.; Loder, A.; Schiavon, S.; Veitch, J.; Wang, L.; Wargocki, P. Ten questions concerning well-being in the built environment. *Build. Environ.* **2020**, *180*, 106949. [[CrossRef](#)]
55. Brager, G.; Baker, L. Occupant satisfaction in mixed-mode buildings. *Build. Res. Inf.* **2009**, *37*, 369–380. [[CrossRef](#)]
56. Lee, Y.S. Comparisons of Indoor Air Quality and Thermal Comfort Quality between Certification Levels of LEED-Certified Buildings in USA. *Indoor Built Environ.* **2011**, *20*, 564–576. [[CrossRef](#)]
57. UNI 10339; Air-Conditioning Systems for Thermal Comfort in Buildings—General, Classification and Requirements—Offer, Order and Supply Specifications. Ente Italiano di Normazione: Milan, Italy, 1995.
58. ASHRAE. *ASHRAE Handbook—Fundamentals*; American Society of Heating, Refrigerating and Air-Conditioning Engineers (ASHRAE): Atlanta, GA, USA, 2021. Available online: <https://www.hrai.ca/technical-manual/residential-mechanical-ventilation---national--sar-r4-> (accessed on 6 June 2022).
59. HRAI Residential Mechanical Ventilation—National (SAR-R4); The Heating, Refrigeration and Air Conditioning Institute of Canada (HRAI): Mississauga, ON, Canada, 2010.
60. Abdul Hamid, A.; Johansson, D.; Bagge, H. Ventilation measures for heritage office buildings in temperate climate for improvement of energy performance and IEQ. *Energy Build.* **2020**, *211*, 109822. [[CrossRef](#)]
61. Diaz de Garayo, S.; Martínez, A.; Astrain, D. Optimal combination of an air-to-air thermoelectric heat pump with a heat recovery system to HVAC a passive house dwelling. *Appl. Energy* **2022**, *309*, 118443. [[CrossRef](#)]
62. Lazzarin, R.M.; Gasparella, A. Technical and economical analysis of heat recovery in building ventilation systems. *Appl. Therm. Eng.* **1998**, *18*, 47–67. [[CrossRef](#)]
63. Mardiana-Idayu, A.; Riffat, S.B. Review on heat recovery technologies for building applications. *Renew. Sustain. Energy Rev.* **2012**, *16*, 1241–1255. [[CrossRef](#)]
64. Chen, J.; Augenbroe, G.; Song, X. Model predictive control strategy for hybrid ventilation building operation. In Proceedings of the Construction Research Congress 2018, New Orleans, LA, USA, 2–4 April 2018; American Society of Civil Engineers: New Orleans, LA, USA; 2018; pp. 390–399.
65. Mathews, E.H.; Shuttleworth, A.G.; Rousseau, P.G. Validation and further development of a novel thermal analysis method. *Build. Environ.* **1994**, *29*, 207–215. [[CrossRef](#)]

66. Meng, X.; Wang, Y.; Xing, X.; Xu, Y. Experimental study on the performance of hybrid buoyancy-driven natural ventilation with a mechanical exhaust system in an industrial building. *Energy Build.* **2020**, *208*, 109674. [CrossRef]
67. Raji, B.; Tenpierik, M.J.; Bokel, R.; van den Dobbelsteen, A. Natural summer ventilation strategies for energy-saving in high-rise buildings: A case study in the Netherlands. *Int. J. Vent.* **2020**, *19*, 25–48. [CrossRef]
68. Heiselberg, P. *Principles of Hybrid Ventilation*; Aalborg University: Hybrid Ventilation Centre: Aalborg, Denmark, 2002. Available online: [https://iea-ebc.org/Data/publications/EBC\\_Annex\\_35\\_Principles\\_of\\_H\\_V.pdf](https://iea-ebc.org/Data/publications/EBC_Annex_35_Principles_of_H_V.pdf) (accessed on 13 May 2022).
69. Rysanek, A. Annex 35—Hybrid Ventilation in New and Retrofitted Office Buildings; Hybrid Ventilation in New and Retrofitted Office Buildings; Faber Maunsell Ltd.: Hertfordshire, UK. Available online: [https://www.iea-ebc.org/Data/publications/EBC\\_Annex\\_35\\_tr.pdf](https://www.iea-ebc.org/Data/publications/EBC_Annex_35_tr.pdf) (accessed on 13 May 2022).
70. Rethinking IEQ Standards for a Warming Post-COVID World—Are Standards Promoting Air Conditioning and Marginalising Natural Ventilation? Available online: <https://www.buildingsandcities.org/insights/commentaries/rethinking-ieq-standards.html> (accessed on 19 May 2022).
71. Azuma, K.; Yanagi, U.; Kagi, N.; Kim, H.; Ogata, M.; Hayashi, M. Environmental factors involved in SARS-CoV-2 transmission: Effect and role of indoor environmental quality in the strategy for COVID-19 infection control. *Environ. Health Prev. Med.* **2020**, *25*, 66. [CrossRef]
72. ASHRAE. *COVID-19 Guidance for Multifamily Building Owners/Managers*; American Society of Heating, Refrigerating and Air-Conditioning Engineers (ASHRAE): Atlanta, GA, USA, 2020. Available online: [https://www.ashrae.org/file%20library/technical%20resources/covid-19/covid-19-guidance-for-multifamily-building-owners\\_managers.pdf](https://www.ashrae.org/file%20library/technical%20resources/covid-19/covid-19-guidance-for-multifamily-building-owners_managers.pdf) (accessed on 4 April 2022).
73. ASHRAE. *Residential COVID-19 Guidance*; American Society of Heating, Refrigerating and Air-Conditioning Engineers (ASHRAE): Atlanta, GA, USA, 2021.
74. ASHRAE. *Residences FAQ*; American Society of Heating, Refrigerating and Air-Conditioning Engineers (ASHRAE): Atlanta, GA, USA, 2021. Available online: <https://www.ashrae.org/technical-resources/residences-faq> (accessed on 4 April 2022).
75. Atkinson, J.; Chartier, Y.; Pessoa-Silva, C.L.; Li, Y.; Seto, W.-H. *Natural Ventilation for Infection Control in Health-Care Settings*; World Health Organization: Geneva, Switzerland, 2009.
76. Short, C.A.; Yao, R.; Luo, G.; Li, B. Exploiting a Hybrid Environmental Design Strategy in the Continental Climate of Beijing. *Int. J. Vent.* **2012**, *11*, 105–130. [CrossRef]
77. CIBSE. *COVID-19: Ventilation. Version 5*; Chartered Institution of Building Services Engineers (CIBSE): London, UK, 2021. Available online: <https://www.cibse.org/emerging-from-lockdown#1> (accessed on 4 April 2022).
78. REHVA. *COVID-19 Guidance. Version 4.1*; Federation of European Heating, Ventilation and Air Conditioning Associations (REHVA): Lausanne, Switzerland, 2021. Available online: <https://www.rehva.eu/activities/covid-19-guidance/rehva-covid-19-guidance> (accessed on 4 April 2022).
79. Rysanek, A.; Nuttall, R.; McCarty, J. Forecasting the impact of climate change on thermal comfort using a weighted ensemble of supervised learning models. *Build. Environ.* **2021**, *190*, 107522. [CrossRef]
80. Systematic Reviews & Other Review Types. Available online: <https://guides.temple.edu/c.php?g=78618&p=4178713#:~:text=A%20systematic%20review%20is%20defined,The%20methods%20used%20must%20be> (accessed on 4 April 2022).
81. Web of Science. Clarivate. Available online: <https://clarivate.com/webofsciencgroup/solutions/web-of-science/> (accessed on 27 April 2022).
82. Transparent Reporting of Systematic Reviews and Meta-Analyses. PRISMA. Available online: <https://prisma-statement.org/> (accessed on 16 April 2022).
83. Orosa, J.A.; Oliveira, A.C. *Passive Methods as a Solution for Improving Indoor Environments*; Springer: Berlin/Heidelberg, Germany, 2012.
84. De Dear, R. The Theory of Thermal Comfort in Naturally Ventilated Indoor Environments—“The Pleasure Principle”. *Int. J. Vent.* **2009**, *8*, 243–250. [CrossRef]
85. Blondeau, P.; Spérandio, M.; Allard, F. Night ventilation for building cooling in summer. *Sol. Energy* **1997**, *61*, 327–335. [CrossRef]
86. Erba, S.; Sangalli, A.; Pagliano, L. Present and future potential of natural night ventilation in nZEBs. *IOP Conf. Ser. Earth Environ. Sci.* **2019**, *296*, 012041. [CrossRef]
87. Mares, I.-C.; Catalina, T.; Istrate, M.-A.; Cucos, A.; Dicu, T.; Burghele, B.D.; Hening, K.; Popescu, L.L.; Popescu, R.S. Research on Best Solution for Improving Indoor Air Quality and Reducing Energy Consumption in a High-Risk Radon Dwelling from Romania. *Int. J. Environ. Res. Public Health* **2021**, *18*, 12482. [CrossRef] [PubMed]
88. Liao, C.; Akimoto, M.; Bivolarova, M.P.; Sekhar, C.; Laverge, J.; Fan, X.; Lan, L.; Wargocki, P. A survey of bedroom ventilation types and the subjective sleep quality associated with them in Danish housing. *Sci. Total Environ.* **2021**, *798*, 149209. [CrossRef] [PubMed]
89. Usman, F.; Bakar, A.R.A. Thermal comfort study using CFD analysis in residential house with mechanical ventilation system. In Proceedings of the AWAM International Conference on Civil Engineering, Penang, Malaysia, 21–22 August 2019; Springer: Cham, Switzerland, 2019; pp. 1613–1628.
90. Barbolini, F.; Cappellacci, P.; Guardigli, L. A Design Strategy to Reach nZEB Standards Integrating Energy Efficiency Measures and Passive Energy Use. *Energy Procedia* **2017**, *111*, 205–214. [CrossRef]
91. Grigoropoulos, E.; Anastaselos, D.; Nižetić, S.; Papadopoulos, A.M. Effective ventilation strategies for net zero-energy buildings in Mediterranean climates. *Int. J. Vent.* **2016**, *16*, 291–307. [CrossRef]



92. Yu, C.W.F.; Kim, J.T. Low-Carbon Housings and Indoor Air Quality. *Indoor Built Environ.* **2012**, *21*, 5–15. [[CrossRef](#)]
93. Razman, R.; Abd, H.; Bin, A.; Abdul, A. *Study on Thermal Comfort in University Hostel Building Case Study at Universiti Tun Hussein Onn Malaysia (UTHM), Batu Pahat*; IACSIT Press: Singapore, 2011; Volume 8. Available online: [https://www.researchgate.net/profile/Abd-Halid-Abdullah/publication/267790423\\_Study\\_On\\_Thermal\\_Comfort\\_In\\_University\\_Hostel\\_Building\\_Case\\_Study\\_At\\_Universiti\\_Tun\\_Hussein\\_Onn\\_Malaysia\\_UTHM\\_Batu\\_Pahat/links/54c3401f0cf256ed5a90e291/Study-On-Thermal-Comfort-In-University-Hostel-Building-Case-Study-At-Universiti-Tun-Hussein-Onn-Malaysia-UTHM-Batu-Pahat.pdf](https://www.researchgate.net/profile/Abd-Halid-Abdullah/publication/267790423_Study_On_Thermal_Comfort_In_University_Hostel_Building_Case_Study_At_Universiti_Tun_Hussein_Onn_Malaysia_UTHM_Batu_Pahat/links/54c3401f0cf256ed5a90e291/Study-On-Thermal-Comfort-In-University-Hostel-Building-Case-Study-At-Universiti-Tun-Hussein-Onn-Malaysia-UTHM-Batu-Pahat.pdf) (accessed on 4 April 2022).
94. Yadeta, C.; Indraganti, M.; Alemayehu, E.; Tucho, G.T. An investigation of human thermal comfort and adaptation in naturally ventilated residential buildings and its implication for energy use in tropical climates of Ethiopia. *Sci. Technol. Built Environ.* **2022**, *28*, 896–915. [[CrossRef](#)]
95. Zhao, Y.; Sun, H.; Tu, D. Effect of mechanical ventilation and natural ventilation on indoor climates in Urumqi residential buildings. *Build. Environ.* **2018**, *144*, 108–118. [[CrossRef](#)]
96. Fernández-Agüera, J.; Domínguez-Amarillo, S.; Alonso, C.; Martín-Consuegra, F. Thermal comfort and indoor air quality in low-income housing in Spain: The influence of airtightness and occupant behaviour. *Energy Build.* **2019**, *199*, 102–114. [[CrossRef](#)]
97. Lai, D.; Qi, Y.; Liu, J.; Dai, X.; Zhao, L.; Wei, S. Ventilation behavior in residential buildings with mechanical ventilation systems across different climate zones in China. *Build. Environ.* **2018**, *143*, 679–690. [[CrossRef](#)]
98. Izadyar, N.; Miller, W.; Rismanchi, B.; Garcia-Hansen, V. Numerical simulation of single-sided natural ventilation: Impacts of balconies opening and depth scale on indoor environment. *IOP Conf. Ser. Earth Environ. Sci.* **2020**, *463*, 012037. [[CrossRef](#)]
99. Izadyar, N.; Miller, W.; Rismanchi, B.; Garcia-Hansen, V. A numerical investigation of balcony geometry impact on single-sided natural ventilation and thermal comfort. *Build. Environ.* **2020**, *177*, 106847. [[CrossRef](#)]
100. Lei, Z.; Liu, C.; Wang, L.; Li, N. Effect of natural ventilation on indoor air quality and thermal comfort in dormitory during winter. *Build. Environ.* **2017**, *125*, 240–247. [[CrossRef](#)]
101. Kalamees, T. Indoor Climate Conditions and Ventilation Performance in Estonian Lightweight Detached Houses. *Indoor Built Environ.* **2006**, *15*, 555–569. [[CrossRef](#)]
102. Torresin, S.; Albatici, R.; Aletta, F.; Babich, F.; Oberman, T.; Kang, J. Associations between indoor soundscapes, building services and window opening behaviour during the COVID-19 lockdown. *Build. Serv. Eng. Res. Technol.* **2021**, *43*, 225–240. [[CrossRef](#)]
103. Cardoso, V.E.M.; Pereira, P.F.; Ramos, N.M.M.; Almeida, R.M.S.F. The Impacts of Air Leakage Paths and Airtightness Levels on Air Change Rates. *Buildings* **2020**, *10*, 55. [[CrossRef](#)]
104. Yin, H.; Zhai, X.; Ning, Y.; Li, Z.; Ma, Z.; Wang, X.; Li, A. Online monitoring of PM<sub>2.5</sub> and CO<sub>2</sub> in residential buildings under different ventilation modes in Xi'an city. *Build. Environ.* **2022**, *207*, 108453. [[CrossRef](#)]
105. Cai, C.; Sun, Z.; Weschler, L.B.; Li, T.; Xu, W.; Zhang, Y. Indoor air quality in schools in Beijing: Field tests, problems and recommendations. *Build. Environ.* **2021**, *205*, 108179. [[CrossRef](#)]
106. Giridharan, R.; Lomas, K.J.; Short, C.A.; Fair, A.J. Performance of hospital spaces in summer: A case study of a 'Nucleus'-type hospital in the UK Midlands. *Energy Build.* **2013**, *66*, 315–328. [[CrossRef](#)]
107. Ding, E.; Zhang, D.; Bluyssen, P.M. Ventilation regimes of school classrooms against airborne transmission of infectious respiratory droplets: A review. *Build. Environ.* **2022**, *207*, 108484. [[CrossRef](#)]
108. Guo, P.; Wang, S.; Xu, B.; Meng, Q.; Wang, Y. Reduced-scale experimental model and numerical investigations to buoyance-driven natural ventilation in a large space building. *Build. Environ.* **2018**, *145*, 24–32. [[CrossRef](#)]
109. Aldawoud, A. Windows design for maximum cross-ventilation in buildings. *Adv. Build. Energy Res.* **2017**, *11*, 67–86. [[CrossRef](#)]
110. Elnabawi, M.H.; Saber, E. Reducing carbon footprint and cooling demand in arid climates using an integrated hybrid ventilation and photovoltaic approach. *Environ. Dev. Sustain.* **2022**, *24*, 3396–3418. [[CrossRef](#)]
111. Rasheed, E.; Byrd, H.; Money, B.; Mbach, J.; Egbelakin, T. Why Are Naturally Ventilated Office Spaces Not Popular in New Zealand? *Sustainability* **2017**, *9*, 902. [[CrossRef](#)]
112. Azarbayjani, M. Climatic based consideration of double skin facade system: Natural ventilation performance of a case study with double skin facade in mediterranean climate. In Proceedings of the BS2013: 13th Conference of International Building Performance Simulation Association, Chambéry, France, 26–28 August 2013.
113. Butala, V.; Muhič, S. Perception of Air Quality and the Thermal Environment in Offices. *Indoor Built Environ.* **2007**, *16*, 302–310. [[CrossRef](#)]
114. Arata, S.; Kawakubo, S. Study on productivity of office workers and power consumption of air conditioners in a mixed-mode ventilation building during springtime. *Build. Environ.* **2022**, *214*, 108923. [[CrossRef](#)]
115. Scheuring, L.; Weller, B. An investigation of ventilation control strategies for louver windows in different climate zones. *Int. J. Vent.* **2021**, *20*, 226–235. [[CrossRef](#)]
116. Natarajan, S.; Rodriguez, J.; Vellei, M. A field study of indoor thermal comfort in the subtropical highland climate of Bogota, Colombia. *J. Build. Eng.* **2015**, *4*, 237–246. [[CrossRef](#)]
117. Dhalluin, A.; Limam, K. Comparison of natural and hybrid ventilation strategies used in classrooms in terms of indoor environmental quality, comfort and energy savings. *Indoor Built Environ.* **2014**, *23*, 527–542. [[CrossRef](#)]
118. Gil-Baez, M.; Barrios-Padura, Á.; Molina-Huelva, M.; Chacartegui, R. Natural ventilation systems in 21st-century for near zero energy school buildings. *Energy* **2017**, *137*, 1186–1200. [[CrossRef](#)]

119. Monge-Barrio, A.; Bes-Rastrollo, M.; Dorregaray-Oyaregui, S.; González-Martínez, P.; Martín-Calvo, N.; López-Hernández, D.; Arriazu-Ramos, A.; Sánchez-Ostiz, A. Encouraging natural ventilation to improve indoor environmental conditions at schools. Case studies in the north of Spain before and during COVID. *Energy Build.* **2022**, *254*, 111567. [CrossRef]
120. Zender-Świercz, E. Microclimate in Rooms Equipped with Decentralized Façade Ventilation Device. *Atmosphere* **2020**, *11*, 800. [CrossRef]
121. Stabile, L.; Buonanno, G.; Frattolillo, A.; Dell'Isola, M. The effect of the ventilation retrofit in a school on CO<sub>2</sub>, airborne particles, and energy consumptions. *Build. Environ.* **2019**, *156*, 1–11. [CrossRef]
122. Heebøll, A.; Wargocki, P.; Toftum, J. Window and door opening behavior, carbon dioxide concentration, temperature, and energy use during the heating season in classrooms with different ventilation retrofits—ASHRAE RP1624. *Sci. Technol. Built Environ.* **2018**, *24*, 626–637. [CrossRef]
123. Khaleghi, A.; Bartlett, K.; Hodgson, M. Factors Affecting Ventilation, Indoor-Air Quality and Acoustical Quality In 'Green' and Non-'Green' Buildings: A Pilot Study. *J. Green Build.* **2011**, *6*, 168–180. [CrossRef]
124. Braham, G.D. Mechanical Ventilation and Fabric Thermal Storage. *Indoor Built Env.* **2000**, *9*, 102–110. [CrossRef]
125. Maas, S.; Da Cruz Antunes, J.; Steffgen, G. Energy efficiency and indoor air quality of seminar rooms in older buildings with and without mechanical ventilation. *Bauphysik* **2019**, *41*, 243–251. [CrossRef]
126. Montgomery, J.F.; Storey, S.; Bartlett, K. Comparison of the indoor air quality in an office operating with natural or mechanical ventilation using short-term intensive pollutant monitoring. *Indoor Built Environ.* **2015**, *24*, 777–787. [CrossRef]
127. Mba, E.J.; Sam-amobi, C.G.; Okeke, F.O. An Assessment of Orientation on Effective Natural Ventilation for Thermal Comfort in Primary School Classrooms in Enugu City, Nigeria. *Eur. J. Sustain. Dev.* **2022**, *11*, 114. [CrossRef]
128. Nardell, E.A. Indoor environmental control of tuberculosis and other airborne infections. *Indoor Air* **2016**, *26*, 79–87. [CrossRef] [PubMed]
129. Homod, R.Z.; Sahari, K.S.M. Energy savings by smart utilization of mechanical and natural ventilation for hybrid residential building model in passive climate. *Energy Build.* **2013**, *60*, 310–329. [CrossRef]
130. Omer, A.M. Renewable building energy systems and passive human comfort solutions. *Renew. Sustain. Energy Rev.* **2008**, *12*, 1562–1587. [CrossRef]
131. Daghigh, R. Assessing the thermal comfort and ventilation in Malaysia and the surrounding regions. *Renew. Sustain. Energy Rev.* **2015**, *48*, 681–691. [CrossRef]
132. Aflaki, A.; Mahyuddin, N.; Al-Cheikh Mahmoud, Z.; Baharum, M.R. A review on natural ventilation applications through building façade components and ventilation openings in tropical climates. *Energy Build.* **2015**, *101*, 153–162. [CrossRef]
133. Perino, M. Short-term airing by natural ventilation—Modeling and control strategies. *Indoor Air* **2009**, *19*, 357–380. [CrossRef] [PubMed]
134. Stavrakakis, G.M.; Koukou, M.K.; Vrachopoulos, M.G.; Markatos, N.C. Natural cross-ventilation in buildings: Building-scale experiments, numerical simulation and thermal comfort evaluation. *Energy Build.* **2008**, *40*, 1666–1681. [CrossRef]
135. Ouyang, Q.; Dai, W.; Li, H.; Zhu, Y. Study on dynamic characteristics of natural and mechanical wind in built environment using spectral analysis. *Build. Environ.* **2006**, *41*, 418–426. [CrossRef]
136. Izadyar, N.; Miller, W.; Rismanchi, B.; Garcia-Hansen, V. Impacts of façade openings' geometry on natural ventilation and occupants' perception: A review. *Build. Environ.* **2020**, *170*, 106613. [CrossRef]
137. Sultan, Z. Estimates of associated outdoor particulate matter health risk and costs reductions from alternative building, ventilation and filtration scenarios. *Sci. Total Environ.* **2007**, *377*, 1–11. [CrossRef]
138. Mukhtar, A.; Yusoff, M.Z.; Ng, K.C. The potential influence of building optimization and passive design strategies on natural ventilation systems in underground buildings: The state of the art. *Tunn. Undergr. Space Technol.* **2019**, *92*, 103065. [CrossRef]
139. Huisman, E.R.C.M.; Morales, E.; van Hoof, J.; Kort, H.S.M. Healing environment: A review of the impact of physical environmental factors on users. *Build. Environ.* **2012**, *58*, 70–80. [CrossRef]
140. Beauchemin, K.M.; Hays, P. Sunny hospital rooms expedite recovery from severe and refractory depressions. *J. Affect. Disord.* **1996**, *40*, 49–51. [CrossRef]
141. Parson, K. *Human Thermal Environments: The Effects of Hot, Moderate, and Cold Environments on Human Health, Comfort, and Performance*; CRC Press: Boca Raton, FL, USA, 2014.
142. CTCN Passive House Design. Available online: <https://www.ctc-n.org/technologies/passive-house-design> (accessed on 8 October 2022).
143. Esposti, R.; Galbusera, G.; Panzeri, A.; Salani, C. *Prestazioni Estive Degli Edifici. Guida Pratica per Capire e Progettare il Comfort e il Fabbisogno Estivo Degli Edifici, 2nd ed*; Associazione Nazionale per l'Isolamento Termico e Acustico (ANIT): Milan, Italy, 2017; Volume 5.
144. ISO 13788:2012; Hygrothermal Performance of Building Components and Building Elements—Internal Surface Temperature to Avoid Critical Surface Humidity And Interstitial Condensation—Calculation Methods. International Organization for Standardization: Geneva, Switzerland, 2012.
145. Rossi, M.; Rocco, V.M. External walls design: The role of periodic thermal transmittance and internal areal heat capacity. *Energy Build.* **2014**, *68*, 732–740. [CrossRef]
146. Di Perna, C.; Stazi, F.; Casalena, A.U.; D'Orazio, M. Influence of the internal inertia of the building envelope on summertime comfort in buildings with high internal heat loads. *Energy Build.* **2011**, *43*, 200–206. [CrossRef]



147. Stazi, F.; Ulpiani, G.; Pergolini, M.; Di Perna, C. The role of areal heat capacity and decrement factor in case of hyper insulated buildings: An experimental study. *Energy Build.* **2018**, *176*, 310–324. [[CrossRef](#)]
148. Figueroa-Lopez, A.; Arias, A.; Oregi, X.; Rodriguez, I. Evaluation of passive strategies, natural ventilation and shading systems, to reduce overheating risk in a passive house tower in the north of Spain during the warm season. *J. Build. Eng.* **2021**, *43*, 102607. [[CrossRef](#)]
149. Mavrogianni, A.; Davies, M.; Taylor, J.; Chalabi, Z.; Biddulph, P.; Oikonomou, E.; Das, P.; Jones, B. The impact of occupancy patterns, occupant-controlled ventilation and shading on indoor overheating risk in domestic environments. *Build. Environ.* **2014**, *78*, 183–198. [[CrossRef](#)]
150. Kim, G.; Lim, H.S.; Lim, T.S.; Schaefer, L.; Kim, J.T. Comparative advantage of an exterior shading device in thermal performance for residential buildings. *Energy Build.* **2012**, *46*, 105–111. [[CrossRef](#)]
151. Callegaro, N.; Pontillo, S.; Albatici, R. Influenza di modelli di gestione per il funzionamento di sistemi oscuranti interni sul consumo energetico e il comfort luminoso. In *New Horizons for Sustainable Architecture—Nuovi Orizzonti per L'architettura sostenibile, Catania, Italy, 10 December 2020*; EdicomEdizioni Atti ColloquiATE: Monfalcone Gorizia, Italy, 2020; pp. 1068–1083. Available online: <https://iris.unitn.it/handle/11572/283955> (accessed on 2 October 2022).
152. Zhao, J.; Du, Y. Multi-objective optimization design for windows and shading configuration considering energy consumption and thermal comfort: A case study for office building in different climatic regions of China. *Sol. Energy* **2020**, *206*, 997–1017. [[CrossRef](#)]
153. Callegaro, N.; Endrizzi, L.; Zaniboni, L.; Albatici, R. Management of indoor thermal conditions in heavy and lightweight buildings: An experimental comparison. In Proceedings of the 14th International Conference on Sustainability in Energy and Buildings, Split, Croatia, 16–17 September 2022. *in press*.



CLIMATE POSITIVE CIRCULAR COMMUNITIES

## **ANNEX**

### **9.3.6 Preliminary analysis energy demand for the New Construction**

# Analisi Preliminare fabbisogno energetico edificio ARV

Gruppo di lavoro Università di Trento – DICAM

R. Albatici, N. Callegaro, A. Prada

5 luglio 2023

Sulla base delle indicazioni riportate nel progetto preliminare dell'edificio nuovo da realizzare all'interno del progetto di ricerca ARV, sono state analizzati diversi scenari sul fabbisogno energetico dell'edificio e sugli scambi di energia con la rete elettrica. Di seguito vengono riassunti le ipotesi adottate, il metodo di calcolo e i principali risultati ottenuti.

## **Metodo di Calcolo**

Il bilancio energetico dell'edificio è stato analizzato adottando il metodo di calcolo quasi-stazionario descritto nelle specifiche tecniche UNI/TS 11300. Tale metodo inoltre è richiamato dalla legislazione nazionale e provinciale sulla verifica dei requisiti energetici minimi per le nuove costruzioni e le riqualificazioni degli edifici esistenti. Mentre la valutazione delle prestazioni energetiche della pompa di calore geotermica è stata svolta su base mensile, in accordo con la UNI/TS 11300-4, la pompa di calore arotermica è stata valutata con il bin-method partendo dalla ricostruzione della distribuzione Gaussiana dei dati climatici contenuti nella norma UNI 10349-1. Sulla base della radiazione solare riportata nella stessa norma, è stata infine valutata la produzione di energia elettrica dei moduli fotovoltaici in copertura e di quelli integrati in facciata, impiegando il metodo definito nella specifica tecnica UNI/TS 11300-4.

## **Ipotesi Progettuali**

I risultati ottenuti si basano su alcune ipotesi sulle prestazioni delle componenti impiantistiche e di involucro non espressamente indicate nel progetto preliminare ma che riflettono dei valori facilmente raggiungibile dagli attuali prodotti commerciali. Per il riscaldamento è stato ipotizzato un impianto di riscaldamento a pavimento con temperatura di mandata a 35°C e regolazione climatica. Lo stesso impianto è utilizzato anche per il raffrescamento estivo, mentre il sistema di ventilazione meccanica, oltre a garantire la qualità dell'ambiente interno, si occupa di controllare l'umidità relativa nel funzionamento estivo dell'impianto. Sono stati considerati infine due diversi impianti di generazione: una pompa di calore arotermica (ASHP) da 7.18 kW nel punto 7/35 con un COP dichiarato nelle stesse condizioni di 4.54 e un

EER di 3.03 nel punto 35/7, e una pompa di calore geotermica (GSHP) da 5.5 kW nel punto 10/35 con un COP dichiarato nelle stesse condizioni di 5.93 e un EER di 4.88 nel punto 30/7. In questa fase i due generatori sono stati assunti come alternativi, mentre nella realtà potranno funzionare in sequenza o con logiche avanzate di regolazione per ottimizzare le prestazioni energetiche.

Per la copertura del fabbisogno di energia con fonti rinnovabili in situ, sono stati considerati due diversi tipi di impianto: un impianto fotovoltaico in copertura e un impianto integrato in facciata (BiPV). Per l'impianto fotovoltaico in copertura è stata assunta un'efficienza nominale di conversione del 21% valutando poi due diversi scenari. Nel primo sono stati considerati 7 moduli installati mentre nel secondo scenario i 10 moduli installati coprono interamente la superficie disponibile della copertura della porzione di edificio su due livelli. Per il BiPV è stata assunta una efficienza nominale del 12% mentre sono stati valutati due diversi scenari in merito alla trasmittanza solare dell'elemento. Nel primo caso è stato assunto un sistema più trasparente con trasmittanza solare pari a 0.5 in grado di migliorare gli apporti solari con riducendo il fabbisogno invernale ma aumentando di conseguenza il carico estivo. Nel secondo caso invece si è assunto un modulo meno trasparente con trasmittanza solare pari a 0.1.

Riassumendo i diversi scenari progettuali analizzati sono:

- Caso 1: 7 moduli fotovoltaici in copertura, BiPV con trasmittanza solare 0.5, pompa di calore ASHP
- Caso 2: 7 moduli fotovoltaici in copertura, BiPV con trasmittanza solare 0.5, pompa di calore GSHP
- Caso 3: 10 moduli fotovoltaici in copertura, BiPV con trasmittanza solare 0.5, pompa di calore ASHP
- Caso 4: 10 moduli fotovoltaici in copertura, BiPV con trasmittanza solare 0.5, pompa di calore GSHP
- Caso 5: 10 moduli fotovoltaici in copertura, BiPV con trasmittanza solare 0.1, pompa di calore ASHP
- Caso 6: 10 moduli fotovoltaici in copertura, BiPV con trasmittanza solare 0.1, pompa di calore GSHP

## **Risultati**

Di seguito vengono riportati i principali risultati di calcolo. In figura 1 sono rappresentati gli andamenti mensili dell'energia elettrica prodotta dai moduli fotovoltaici in copertura e in facciata e i consumi elettrici per ventilazione e illuminazione comuni ai diversi scenari analizzati.

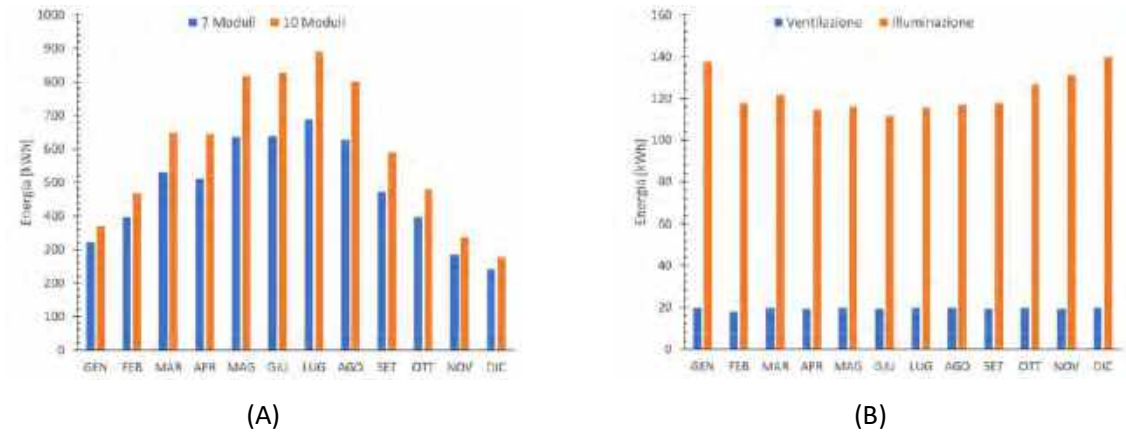


Figura 1: Andamento mensile dell'energia prodotta dal fotovoltaico e consumi mensili per ventilazione e illuminazione

Dal grafico in Figura 1A si nota come la produzione annuale di fotovoltaico varia da 5747.2 kWh nello scenario con 7 moduli in copertura a 7146.2 kWh nello scenario con 10 moduli. Il grafico in Figura 1B mostra invece deboli variazioni mensili nel fabbisogno di energia elettrica per illuminazione e ventilazione che assumono un valore annuale rispettivamente di 1466.21 e 233.60 kWh annuali. Sommando a questi consumi, gli assorbimenti elettrici per il funzionamento della pompa di calore per la climatizzazione e la produzione di acqua calda sanitaria, si ottengono gli andamenti riportati in Figura 2 nello scenario con facciata BiPV più (A) o meno (B) trasparente. Gli andamenti mostrano chiaramente un aumento dei consumi nel caso (B) legata ad un aumento sensibile dei consumi nel periodo invernale, a causa dei ridotti apporti solari, compensata solo in maniera minimale dalla riduzione dei consumi nei mesi estivi. Il grafico mostra inoltre una maggior sensibilità della pompa di calore aerotermica, con un aumento molto più marcato dei consumi elettrici, in parte motivato dal funzionamento in condizioni di carico meno vantaggiose del compressore e soprattutto dalla necessità di un backup elettrico per coprire l'eccedenza di carico.



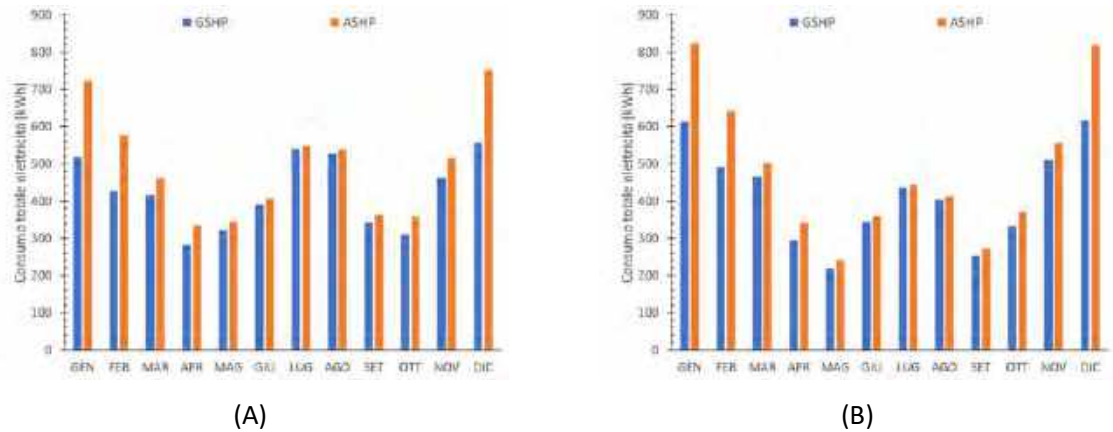


Figura 2: Andamento mensile del consumo totale di elettricità dell'edificio per climatizzazione, ventilazione e illuminazione con trasmittanza solare di 0.5 (A) e di 0.1 (B) del modulo BiPV

Complessivamente i consumi totali elettrici annuali dell'edificio in caso di impiego della pompa di calore aereotermica sono pari 5924.5 e 5788.4 kWh rispettivamente con trasmittanza solare di 0.5 e 0.1 del modulo BiPV. Nel caso di pompa di calore geotermica i consumi risultano essere pari a 5098.9 e 4980.8 kWh sempre nel caso di trasmittanza solare di 0.5 e 0.1 del modulo BiPV. Facendo un bilancio mensile dell'energia prelevata dalla rete (negativa) e di quella immessa in rete (positiva) nei diversi scenari si ottengono gli andamenti riportati nelle figure seguenti:

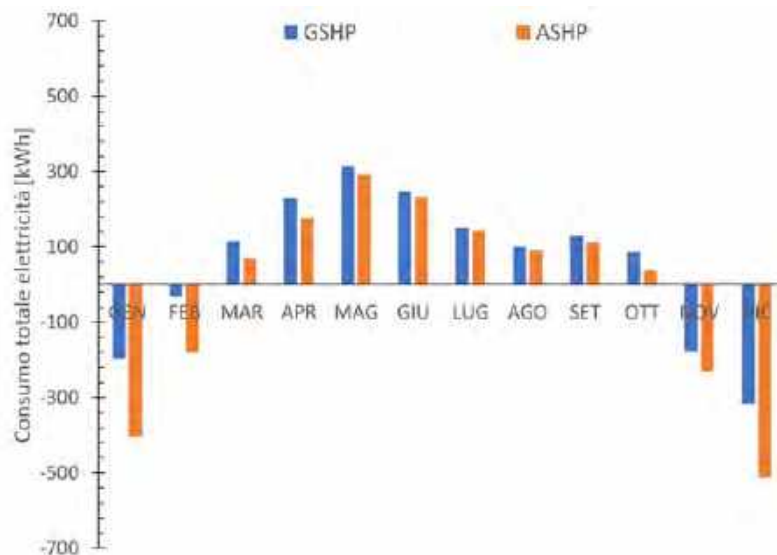


Figura 3: Andamento degli scambi con la rete con 7 moduli PV in copertura e BiPV con trasmittanza 0.5

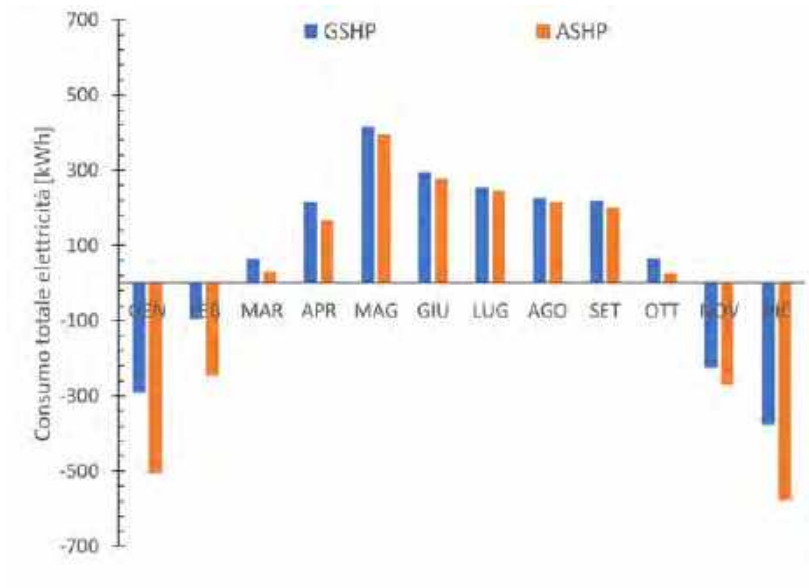


Figura 4: Andamento degli scambi con la rete con 7 moduli PV in copertura e BiPV con trasmittanza 0.1



Figura 5: Andamento degli scambi con la rete con 10 moduli PV in copertura e BiPV con trasmittanza 0.5

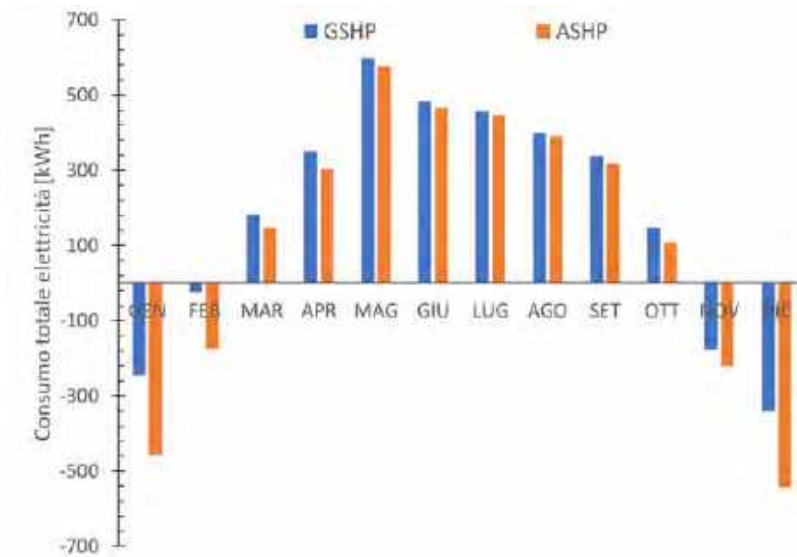


Figura 6: Andamento degli scambi con la rete con 10 moduli PV in copertura e BiPV con trasmittanza 0.1

Analizzando il bilancio annuale degli scambi con la rete si ottiene:

PV in copertura BiPV g-value	7 moduli		10 moduli	
	0.1	0.5	0.1	0.5
GSHP /(kWh)	766.43	648.31	2165.34	2047.22
ASHP /(kWh)	-41.14	-177.22	1357.77	1221.69

## Conclusioni

Dall' analisi preliminare sui fabbisogni energetici per climatizzazione, ventilazione e illuminazione dell'edificio ARV emerge, nell'ipotesi di funzionamento alternativo della pompa di calore geotermica e quella aerotermica, quanto segue:

- L'edificio ha un bilancio positivo (immette in rete più di quanto preleva) con 7 e 10 pannelli nel caso di impianto con pompa di calore geotermica indipendentemente dalle caratteristiche di trasparenza della facciata BiPV.
- Nel caso di pompa di calore aerotermica sono richiesti almeno 10 moduli fotovoltaici in copertura per raggiungere un bilancio positivo su base annuale per quanto concerne gli scambi con la rete elettrica.

- Le caratteristiche di trasparenza della facciata BiPV hanno un leggero impatto sul bilancio l'edificio. In generale, date le caratteristiche del clima, prevale nel bilancio l'effetto benefico della maggior quantità di apporti solari nei mesi invernali sui maggiori carichi di raffrescamento.

## **ANNEX**

### **9.3.7 Table of Meetings with Stakeholders for the New Construction**

**D4.5 DESIGN GUIDELINES OF CLIMATE POSITIVE CIRCULAR COMMUNITY IN TRENTO**

**WP4 SUSTAINABLE BUILDING (RE) DESIGN**



Table\_ Meetings with STAKEHOLDERS\_TRENTO DEMONSTRATION PROJECT\_DD of the New Building in Area 4

WHEN	WHO and WHERE	PARTICIPANTS	ITEMS discussed	NOTE	STEP
10/02/2023	<b>Municipality of Trento</b> via Alfieri n.6 Trento	<b>EURAC</b> - dott. D. Vettorato <b>UNITN</b> - Prof. R. Albatici - prof. A. Frattari <b>HABITECH</b> - dott. M. Curci - dott. A. Fronk <b>Municipality of Trento</b> - ing. G. Franzoi (Mobility and Urban Regeneration Department) - ing. S. Fedrizzi (Urban Planning Service) <b>ARMALAM</b> ing. F. Ferrario	Redefinition of the New Building in Area 4 due budget constraints  Administrative procedure		DD
<u>12/04/2023</u>	<b>INTERNAL ACTORS</b> University of Trento, DICAM, via Mesiano 77, Trento	<b>EURAC</b> - dott. D. Vettorato <b>UNITN</b> - prof. R. Albatici <b>HABITECH</b> - dott. M. Curci - dott. M. Dell'Antonio <b>FANTI LEGNAMI S.R.L</b> - M. Fanti	Application of the Renew Wall system on the New Building		DD
24.05.2023	<b>INTERNAL ACTORS</b>	<b>UNITN</b> - prof. I. Giongo <b>HABITECH</b>	New Building in Area 4: timber frame		DD

	Meeting in Microsoft Teams	<ul style="list-style-type: none"> <li>- dott. M. Curci</li> </ul> <p><b>ARMALAM</b></p> <ul style="list-style-type: none"> <li>- ing. F. Ferrario</li> <li>- ing. M. Tommasini</li> </ul> <p><b>XLAM DOLOMITI</b></p> <ul style="list-style-type: none"> <li>- ing. D. Fanti</li> <li>- ing. A. Angeli</li> </ul> <p><b>FANTI LEGNAMI S.R.L</b></p> <ul style="list-style-type: none"> <li>- M. Fanti</li> </ul>	Construction system and bracing solutions.		
01.06.2023	<p><b>Municipality of Trento</b></p> <p>via Alfieri n.6 Trento</p>	<p><b>EURAC</b></p> <ul style="list-style-type: none"> <li>- dott. D. Vettorato</li> </ul> <p><b>HABITECH</b></p> <ul style="list-style-type: none"> <li>- dott. M. Curci</li> </ul> <p><b>Municipality of Trento</b></p> <ul style="list-style-type: none"> <li>- ing. G. Franzoi (Mobility and Urban Regeneration Department)</li> <li>- ing. S. Fedrizzi (Urban Planning Service)</li> </ul>	Administrative procedure		DD
07.06.2023	<p><b>Municipality of Trento</b></p> <p>via Alfieri n.6 Trento</p>	<p><b>EURAC</b></p> <ul style="list-style-type: none"> <li>- dott. D. Vettorato</li> </ul> <p><b>Municipality of Trento</b></p> <ul style="list-style-type: none"> <li>- ing. G. Franzoi (Mobility and Urban Regeneration Department)</li> <li>- ing. S. Fedrizzi (Urban Planning Service)</li> </ul>	Administrative procedure		DD

31.08.2023	<b>Municipality of Trento</b> via Alfieri n.6 Trento	<b>Municipality of Trento</b> - ing. G. Franzoi (Mobility and Urban Regeneration Department)  <b>EURAC</b> - dott. D. Vettorato  <b>HABITECH</b> - dott. M. Curci  <b>ARMALAM</b> - ing. F. Ferrario	Administrative procedure		DD
07/09/2023	<b>INTERNAL ACTORS</b>	<b>UNITN</b> - prof. I. Giongo  <b>HABITECH</b> - dott. M. Curci  <b>ARMALAM</b> - ing. F. Ferrario - ing. M. Tommasini  <b>XLAM DOLOMITI</b> - ing. D. Fanti  <b>FANTI LEGNAMI S.R.L</b> - M. Fanti	New Building in Area 4: timber frame Construction system and bracing solutions.		DD
23/10/2023	<b>INTERNAL ACTORS</b> <b>+ EXTERNAL ACTORS</b>	<b>UNITN</b> - prof. R. Albatici - ing. G. Maracchini - prof. M Dalprà - prof. A. Prada  <b>POLITO</b> - arch. P.Simeone - porf. M. Barla - ing. A. Insana	Building envelope – Building System coordination meeting	Participants discussed and shared solutions concerning: the new configuration of the external facades developed in DD and the monitoring needs; the integration of the new PVT system (developed by Polito) in the Renew Wall panel; the use of an innovative insulating material (developed by Polito) for the south wall; the application of the "green" finish onsite and not offsite on the Renew Wall module; issues regarding the underground reinforced concrete walls and the geothermal system.	DD

		<p><b>HABITECH</b></p> <ul style="list-style-type: none"> <li>- dott. M. Curci</li> <li>- dott. A. Fromk</li> </ul> <p><b>ARMALAM</b></p> <ul style="list-style-type: none"> <li>- ing. F. Ferrario</li> <li>- arch. D. Casagrande</li> </ul> <p><b>XLAM DOLOMITI</b></p> <ul style="list-style-type: none"> <li>- ing. D. Fanti</li> </ul> <p><b>LEVA SRL</b></p> <ul style="list-style-type: none"> <li>- ing. N. Veronesi</li> </ul>			
27/10/2023	<p><b>Citizens of Piedicastello (Trento)</b> sala circoscrizionale in VIA VERRUCA n. 1 - PIEDICASTELLO</p>	<p><b>Municipality of Trento</b></p> <ul style="list-style-type: none"> <li>- council member M. Baggia (Land use planning and private building Department)</li> <li>- council member E. Facchin (Mobility and Ecological Transition Department)</li> </ul> <p><b>Patrimonio del Trentino</b></p> <ul style="list-style-type: none"> <li>- dott. M. Maistri</li> </ul> <p><b>EURAC</b></p> <ul style="list-style-type: none"> <li>- dott. D. Vettorato</li> </ul> <p><b>HABITECH</b></p> <ul style="list-style-type: none"> <li>- dott. M. Curci</li> </ul> <p><b>UNITN</b></p> <ul style="list-style-type: none"> <li>- prof. R. Albatici</li> </ul> <p><b>ARMALAM</b></p> <ul style="list-style-type: none"> <li>- ing. F. Ferrario</li> </ul> <p><b>DOLOMITI ENERGIA</b></p>	<p>The ARV project in Trento: activities, developments and synergies with the transformations of the Piedicastello district.</p> <p>Rounde table and discussion.</p>	<p>This is the second public meeting with citizens and residents of the Piedicastello district.</p> <p>Title of the meeting “Scenarios and perspectives of urban transformation for Piedicastello - The European ARV project”. Promotion with flyer, communication via social facebook groups.</p>	DD

		<ul style="list-style-type: none"><li>- ing. F. Righi</li></ul> <b>Circostrizione Centro Storico Piedicastello</b> <ul style="list-style-type: none"><li>- ing. C. Geat (President)</li><li>- citizens and residents</li></ul>			





CLIMATE POSITIVE CIRCULAR COMMUNITIES

## **ANNEX**

### 9.3.8 Design guidelines for the integration of PV in architectural design

D4.5 DESIGN GUIDELINES OF CLIMATE POSITIVE CIRCULAR COMMUNITY IN TRENTO

WP4 SUSTAINABLE BUILDING (RE) DESIGN

# CLIMATE POSITIVE CIRCULAR COMMUNITIES

## ARV PROJECT

*WP 4 / Architectural and aesthetic integration of BIPV/BAPV/PVT solutions; materials selection; integration between PV, Solar Thermal and CMV systems.*

*WP 5 / Definition of possible layers and materials (bio-based and/or recycled): outer finishing (including green solutions, nano-based materials, reflective finishes, PV panels), ventilated façade, insulation, system/facilities passage (within the module or intra modules), inner finishing (including PCM and massive solutions)*

DAD / DIPARTIMENTO DI ARCHITETTURA E DESIGN - Politecnico di Torino  
03/10/2023

### PROGETTO //

ARV Project  
Climate Positive Circular  
Communities

WP 4 / WP 5

### TEAM //

Daniela Bosia  
Guido Callegari  
*responsabile scientifico*  
Eleonora Merolla  
Guglielmo Ricciardi  
Giuseppe Roccasalva  
Lorenzo Savio  
Paolo Simeone

DAD / Dipartimento di  
Architettura e Design  
Politecnico di Torino

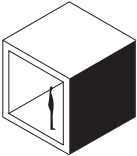


**Politecnico  
di Torino**

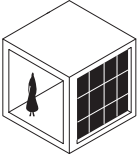
Dipartimento  
di Architettura e Design

# LINEE DI INDIRIZZO PROGETTUALE PER L'INTEGRAZIONE DEL FOTOVOLTAICO NEL PROGETTO DI ARCHITETTURA

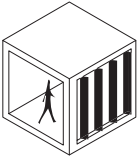
Ipotesi di integrazione fotovoltaica per il Demo Project di Trento - progetto ARV  
Area ex Zuffo



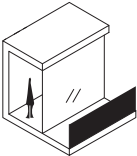
Rivestimento di facciata



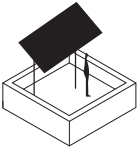
Facciata continua trasparente



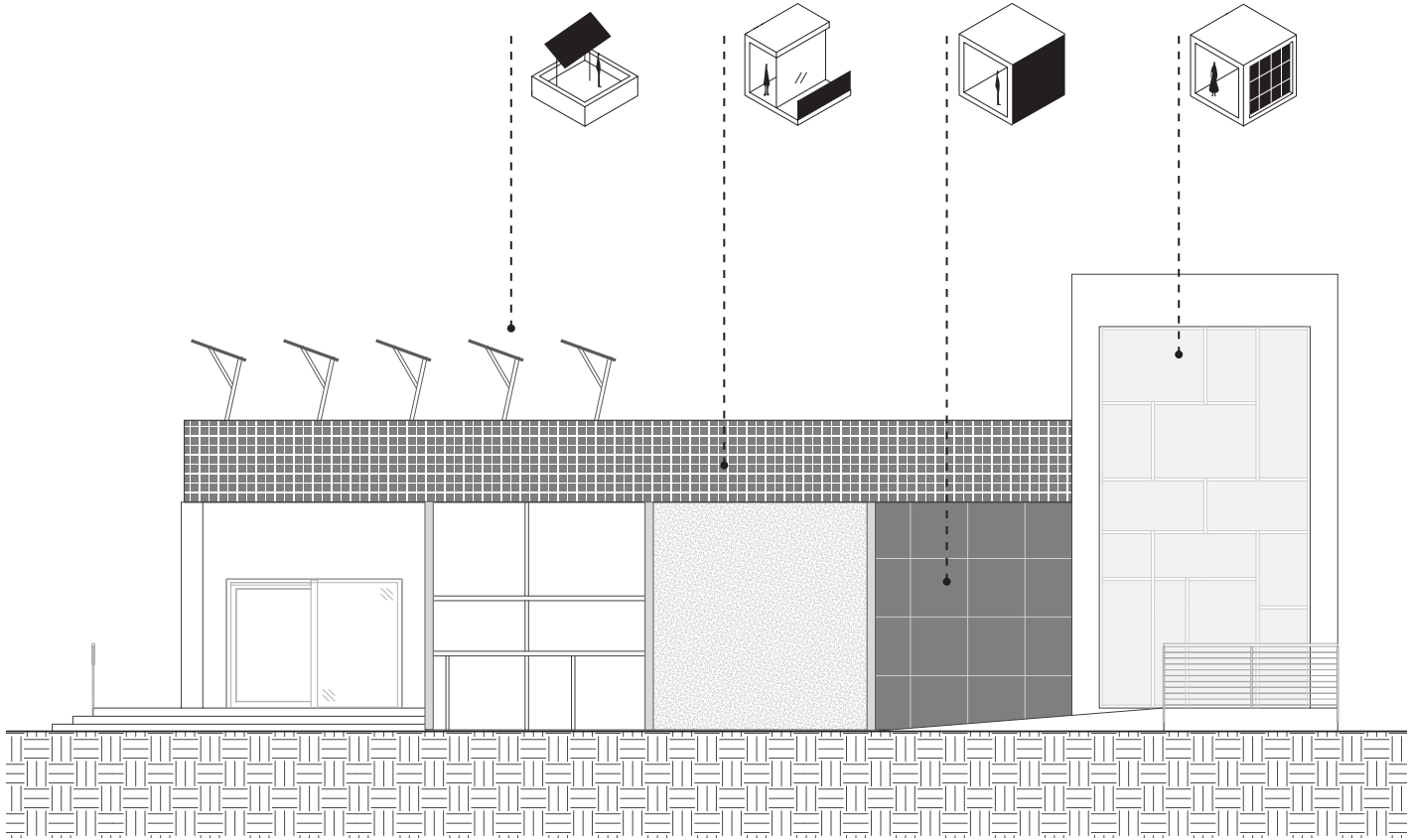
Schermatura solare verticale



Parapetto



Schermatura solare inclinata (tipo pensilina)



Categorie di integrazione

**PROGETTO //**

ARV Project  
Climate Positive Circular  
Communities

WP 4 / WP 5

**TEAM //**

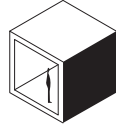
- Daniela Bosia
- Guido Callegari  
*responsabile scientifico*
- Eleonora Merolla
- Guglielmo Ricciardi
- Giuseppe Roccasalva
- Lorenzo Savio
- Paolo Simeone

DAD / Dipartimento di  
Architettura e Design  
Politecnico di Torino

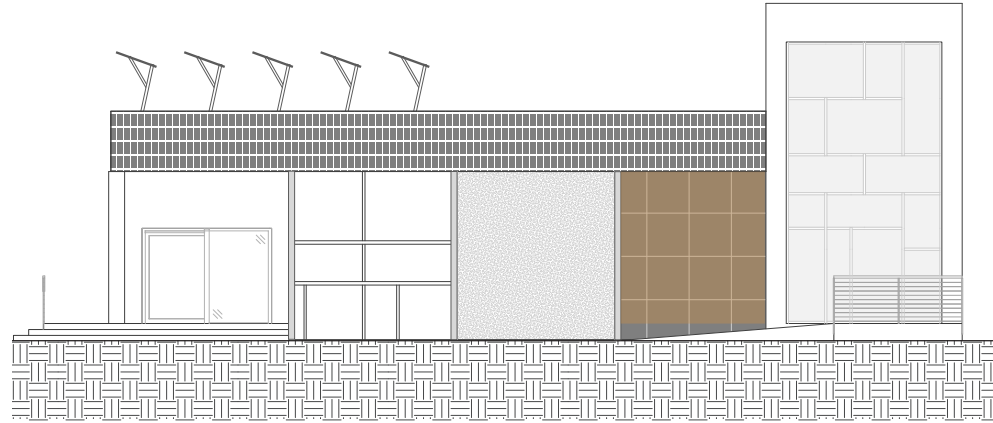


**Politecnico di Torino**

Dipartimento di Architettura e Design



## INTEGRAZIONE PV COME RIVESTIMENTO OPACO



**Edificio polifunzionale** / Pregassona (CH),  
2022

PRODUTTORE	SUNAGE
TECNOLOGIA PV	FOTOVOLTAICO MONOCRISTALLINO
MODULO PV	MODULO FOTOVOLTAICO VETRO-VETRO
CARATTERISTICA VISIVA	FOTOVOLTAICO MIMETICO
TRASPARENZA	OPACO
TRATTAMENTO COLORE	VETRO FRONTALE SATINATO



### PROGETTO //

ARV Project  
Climate Positive Circular  
Communities

WP 4 / WP 5

### TEAM //

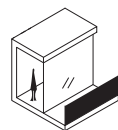
Daniela Bosia  
Guido Callegari  
*responsabile scientifico*  
Eleonora Merolla  
Guglielmo Ricciardi  
Giuseppe Roccasalva  
Lorenzo Savio  
Paolo Simeone

DAD / Dipartimento di  
Architettura e Design  
Politecnico di Torino

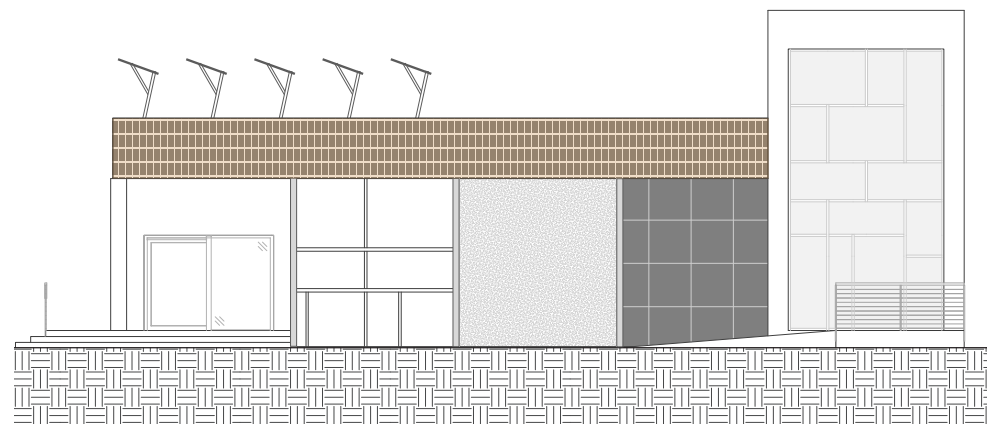


**Politecnico  
di Torino**

Dipartimento  
di Architettura e Design



## INTEGRAZIONE PV SUL PARAPETTO



### Condominio Altstetten / Zurigo (CH), 2017

*Kämpfen Für Architektur*

Edificio in legno con certificazione Minergie P-ECO

PRODUTTORE	ERTEX SOLAR
TECNOLOGIA PV	FOTOVOLTAICO POLICRISTALLINO
MODULO PV	MODULO FOTOVOLTAICO VETRO-VETRO
CARATTERISTICA VISIVA	FOTOVOLTAICO RICONOSCIBILE
TRASPARENZA	OPACO
TRATTAMENTO COLORE	CELLE FOTOVOLTAICHE COLORATE



#### PROGETTO //

ARV Project  
Climate Positive Circular  
Communities

WP 4 / WP 5

#### TEAM //

Daniela Bosia  
Guido Callegari  
*responsabile scientifico*  
Eleonora Merolla  
Guglielmo Ricciardi  
Giuseppe Roccasalva  
Lorenzo Savio  
Paolo Simeone

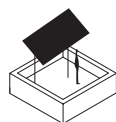
DAD / Dipartimento di  
Architettura e Design  
Politecnico di Torino



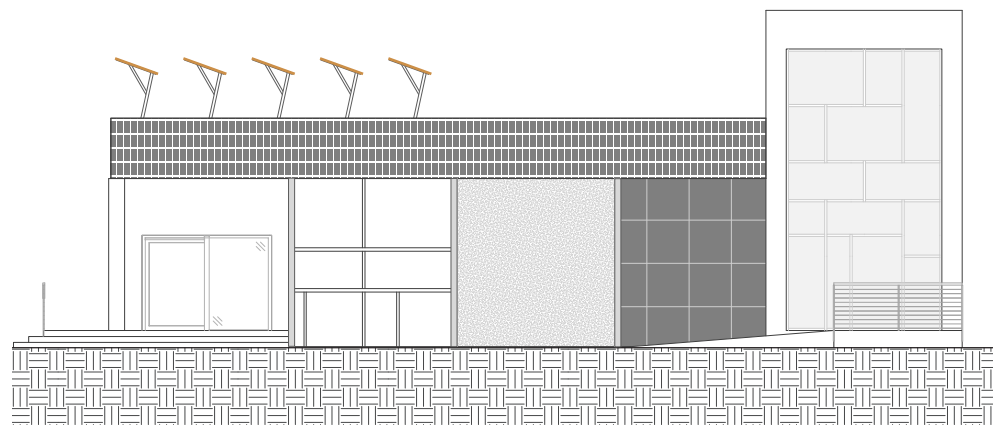
**Politecnico  
di Torino**

Dipartimento  
di Architettura e Design





## INTEGRAZIONE PV SU PENSILINE



**Banca Popolare Etica / Padova, 2012**  
*Tam Associati*

PRODUTTORE	--
TECNOLOGIA PV	FOTOVOLTAICO MONOCRISTALLINO
MODULO PV	MODULO FOTOVOLTAICO - BACKSHEET CON TELAIO
CARATTERISTICA VISIVA	FOTOVOLTAICO RICONOSCIBILE
TRASPARENZA	OPACO
TRATTAMENTO COLORE	CELLE FOTOVOLTAICHE STANDARD



### PROGETTO //

ARV Project  
 Climate Positive Circular  
 Communities

WP 4 / WP 5

### TEAM //

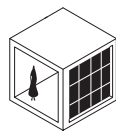
Daniela Bosia  
 Guido Callegari  
*responsabile scientifico*  
 Eleonora Merolla  
 Guglielmo Ricciardi  
 Giuseppe Roccasalva  
 Lorenzo Savio  
 Paolo Simeone

DAD / Dipartimento di  
 Architettura e Design  
 Politecnico di Torino

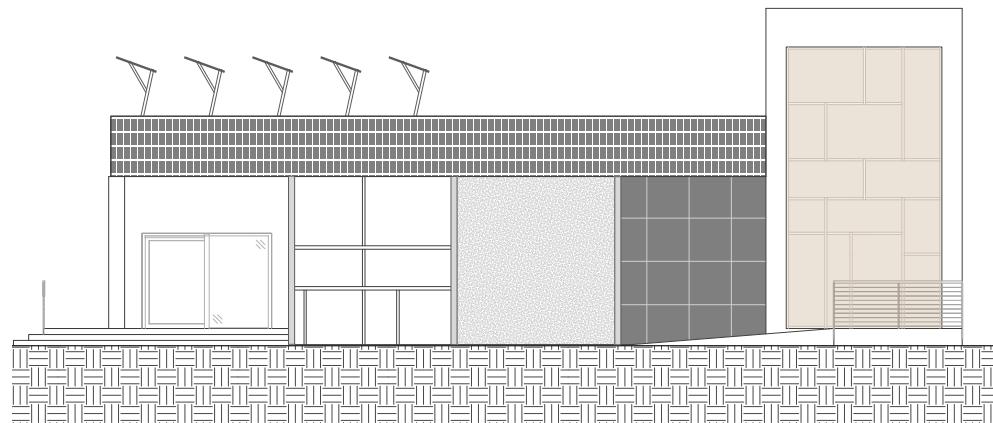


**Politecnico  
 di Torino**

Dipartimento  
 di Architettura e Design



## INTEGRAZIONE PV IN FACCIATE CONTINUE



B



**Social Housing / Torino, 2013**  
Fagnoni&Associati architetti

A

**Sede centrale Bursagaz /**  
Bursa (TR), 2013

PRODUTTORE	ONYX SOLAR
TECNOLOGIA PV	SILICIO AMORFO
MODULO PV	SILICIO AMORFO LAMINATO NEL VETRO DELLA FACCIATA CONTINUA
CARATTERISTICA VISIVA	FOTOVOLTAICO NON VISIBILE
TRASPARENZA	TRASPARENTE
TRATTAMENTO COLORE	NESSUNO

PRODUTTORE	--
TECNOLOGIA PV	FOTOVOLTAICO MONOCRISTALLINO
MODULO PV	CELLE PV LAMINATE NEL VETRO DELLA FACCIATA CONTINUA
CARATTERISTICA VISIVA	FOTOVOLTAICO RICONOSCIBILE
TRASPARENZA	OPACO
TRATTAMENTO COLORE	CELLE FOTOVOLTAICHE STANDARD

### PROGETTO //

ARV Project  
Climate Positive Circular  
Communities

WP 4 / WP 5

### TEAM //

Daniela Bosia  
Guido Callegari  
*responsabile scientifico*  
Eleonora Merolla  
Guglielmo Ricciardi  
Giuseppe Roccasalva  
Lorenzo Savio  
Paolo Simeone

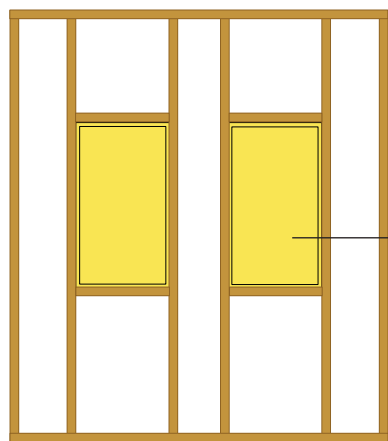
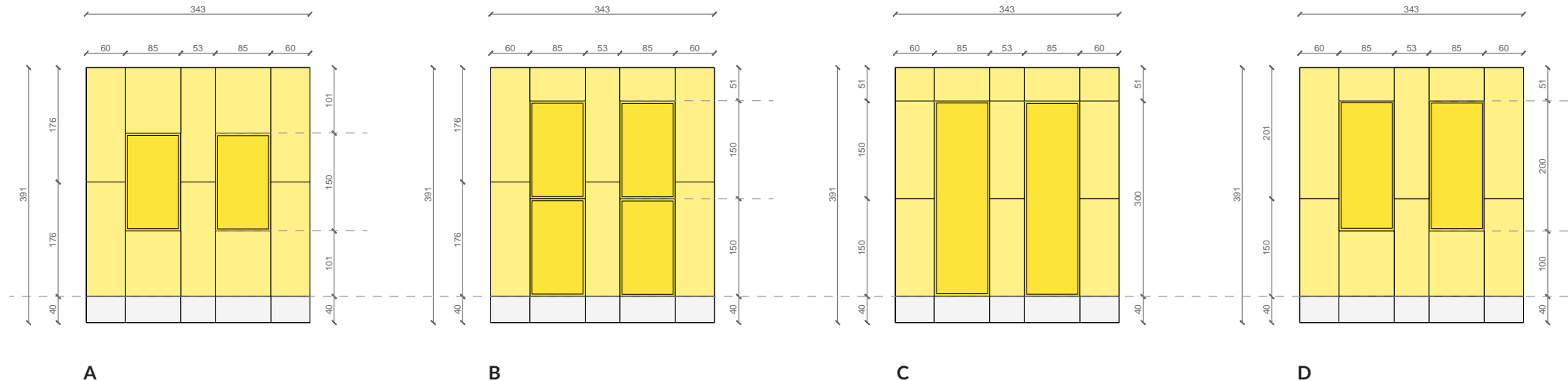
DAD / Dipartimento di  
Architettura e Design  
Politecnico di Torino



**Politecnico  
di Torino**

Dipartimento  
di Architettura e Design

# PROPOSTE DI CONFIGURAZIONE INTEGRAZIONE BIPV - INVOLUCRO VERTICALE OPACO



Inserimento del sistema PVT nel telaio della parete

STRUTTURA PORTANTE DELLA PARETE RENEW - WALL

- Modulo PV per integrazione in sistema PVT
- Modulo PV per integrazione in facciata ventilata
- Pannello di rivestimento per facciata ventilata

## PROGETTO //

ARV Project  
Climate Positive Circular  
Communities

WP 4 / WP 5

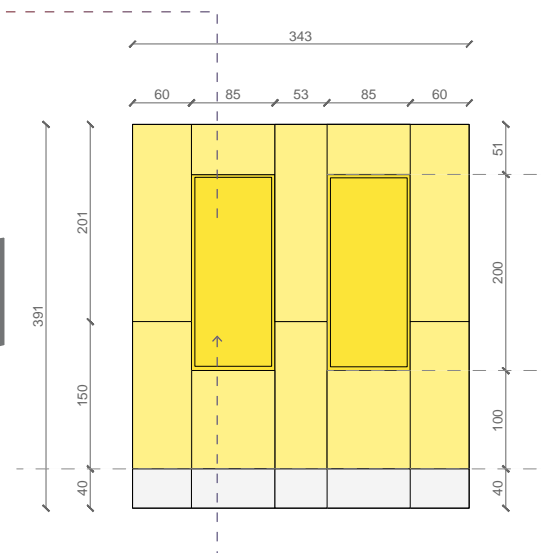
## TEAM //

Daniela Bosia  
Guido Callegari  
*responsabile scientifico*  
Eleonora Merolla  
Guglielmo Ricciardi  
Giuseppe Roccasalva  
Lorenzo Savio  
Paolo Simeone

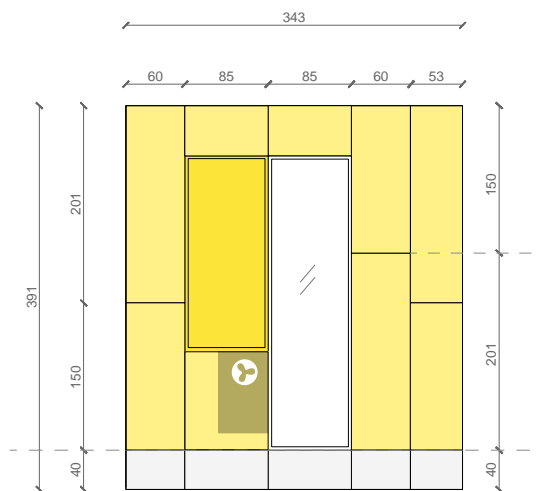
DAD / Dipartimento di  
Architettura e Design  
Politecnico di Torino

# PROPOSTE COLLEGAMENTO TECNOLOGIA PVT (fotovoltaico solare termico) - SISTEMA VMC

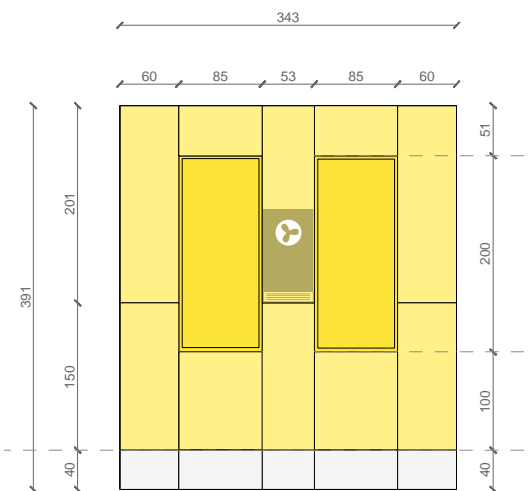
## A / COLLEGAMENTO CON IL SISTEMA IMPIANTISTICO DELL'EDIFICIO



## B / COLLEGAMENTO CON VMC PUNTUALE INTEGRATA NELLA STRATIGRAFIA DELLA PARETE



a / presenza di serramento



b / assenza di serramento

- Modulo PV per integrazione in sistema PVT
- Modulo PV per integrazione in facciata ventilata
- Pannello di rivestimento per facciata ventilata

NB. Sistema PVT con necessità di collegamento elettrico

### PROGETTO //

ARV Project  
Climate Positive Circular  
Communities

WP 4 / WP 5

### TEAM //

Daniela Bosia  
Guido Callegari  
*responsabile scientifico*  
Eleonora Merolla  
Guglielmo Ricciardi  
Giuseppe Roccasalva  
Lorenzo Savio  
Paolo Simeone

DAD / Dipartimento di  
Architettura e Design  
Politecnico di Torino



## ISOLANTE IN LANA DI PECORA PER PARETE RENEW - WALL

### CARTONLANA



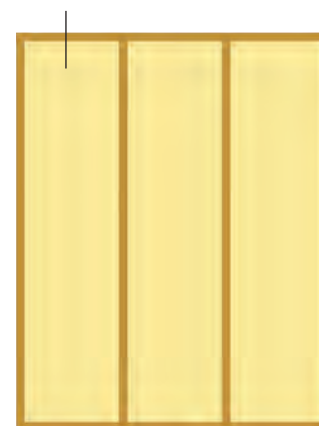
Risultato di un progetto di ricerca realizzato dalla DAVIFIL in collaborazione con il CNR ISMAC di Biella ed il POLITECNICO di TORINO.

Prodotto brevettato -  
n. brevetto 0001410156  
Certificazione e schede tecniche prodotto realizzate da Istituto Giordano INRIM e CNR-ISMAL

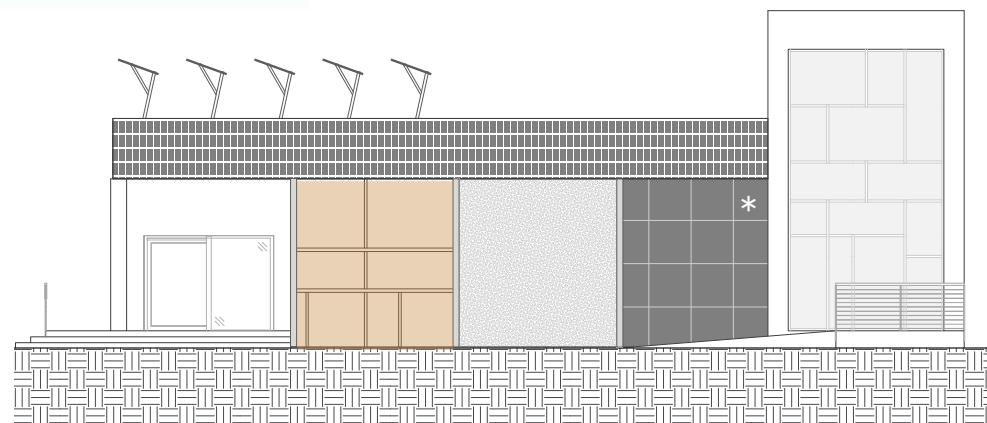
Pannelli rigidi in 100% lana di pecora. Prodotto naturale, innovativo, riciclabile, con ottime prestazioni di fonoassorbimento e di coibentazione.

<https://www.davifil-bioisol.com/>

Utilizzo di CARTONLANA  
(brevetto n. 0001410156)  
per parete Renew-Wall



STRUTTURA PORTANTE  
DELLA PARETE RENEW - WALL



Parete di riferimento per la posa del CARTONLANA  
(ipotesi di utilizzo di CARTONLANA anche per la parete BIPV opaca\*)

#### PROGETTO //

ARV Project  
Climate Positive Circular  
Communities

WP 4 / WP 5

#### TEAM //

Daniela Bosia  
Guido Callegari  
*responsabile scientifico*  
Eleonora Merolla  
Guglielmo Ricciardi  
Giuseppe Roccasalva  
Lorenzo Savio  
Paolo Simeone

DAD / Dipartimento di  
Architettura e Design  
Politecnico di Torino

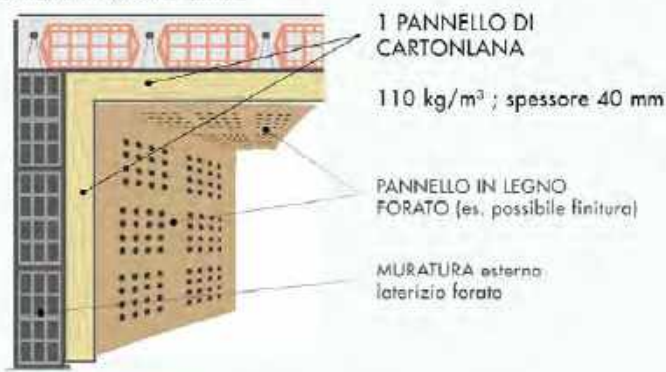


**Politecnico  
di Torino**

Dipartimento  
di Architettura e Design



insonorizzazione pareti e soffitti  
coibentazione pareti e soffitti



## CARATTERISTICHE TECNICHE

Spessore: 4 cm

Densità: da 110 kg. al m<sup>3</sup>

Dimensioni Pannello: 52x90 cm

Conduttività termica: "λ" = 0,040 W/m.k

Coefficiente di assorbimento acustico: "αS" = 0,55 (MH)

Permeabilità al vapore acqueo: "δ" = 0,31 mg/(m•h•Pa)

Assorbimento formaldeide: ALTO

Impieghi: coibentazione pareti e soffitti, insonorizzazione pareti e soffitti, intercapedini e sottotetti, cappotti esterni ed interni

<https://www.davifil-bioisol.com/>

## Isolanti termoacustici in Lana di Pecora - principali caratteristiche fisiche, tecnologiche ed energetiche Wool thermal insulations – Summary of physical, technological and energy parameters

	Materassini agugliati in rotoli	Cartonlana
	Wool insulation – rolls	(estimate value)
Densità [kg/m <sup>3</sup> ] Density	15-20-25	40-50
Calore Specifico kJ/kg Specific heat capacity	1,3-1,7	1,3-1,7
Coefficiente di resistenza alla diffusione del vapore acqueo[μ] Water vapour resistance factor	1-5	5-6
Conduttività Termica [W/mK] Design thermal conductivity	0,037-0,040	0,040-0,045 (4)
Classe di Reazione al Fuoco Fire rating classification (Italian standard)	I	I
Modalità di posa in opera Method of installation	accostamento combination (dry system)	sistema umido, accostamento, incastro serraggio humid and dry systems combination
Durata stimata [anni] Durability [years]	50-65	50-75
Modalità di installazione: Method of installation:	isolamento in intercapedine, isolamento di solaio su sottotetto non riscaldato cavity wall/roofs	isolamento interno, esterno e in intercapedine di chiusure verticali, isolamento di solai interni e coperture orizzontali e inclinate wall insulation (cavity wall or internal side), external wall insulation, roofs, floors
Contenuto di energia primaria per 1 kg di prodotto [MJ/kg] Primary Energy Content [MJ/kg]	19,26	21,18

Tabella 1

Principali caratteristiche fisico tecniche degli isolanti in Lana di Pecora attualmente utilizzati (materassini agugliati) e dei pannelli di CARTONLANA

Table 1

Main features of sheep's wool insulation currently used and CARTONLANA panels

Bosia, Daniela & Giordano, Roberto & Savio, Lorenzo. (2011). A sustainable building product: advanced insulation panels obtained by recycling regional sheep's wool. *Techne : Journal of Technology for Architecture and Environment*. 1. 10.13128/Techne-9443.

PROGETTO //

ARV Project  
Climate Positive Circular  
Communities

WP 4 / WP 5

TEAM //

Daniela Bosia  
Guido Callegari  
*responsabile scientifico*  
Eleonora Merolla  
Guglielmo Ricciardi  
Giuseppe Roccasalva  
Lorenzo Savio  
Paolo Simeone

DAD / Dipartimento di  
Architettura e Design  
Politecnico di Torino



**Politecnico  
di Torino**

Dipartimento  
di Architettura e Design

## **ANNEX**

### **9.3.9 Table of Meetings with Stakeholders for the Refurbishment**

**D4.5 DESIGN GUIDELINES OF CLIMATE POSITIVE CIRCULAR COMMUNITY IN TRENTO**

**WP4 SUSTAINABLE BUILDING (RE) DESIGN**

**Table\_ Meetings with STAKEHOLDERS\_TRENTO DEMONSTRATION PROJECT\_ ECD, DD, DeD of the Existing Building in Povo district**

WHEN	WHO and WHERE	PARTICIPANTS	ITEMS discussed	NOTE	STEP
22.03.2023	<b>INTERNAL ACTORS</b> Online meeting	<b>EURAC</b> - dott. D. Vettorato <b>UNITN</b> - prof. R. Albatici <b>HABITECH</b> - dott. M. Curci	Existing Building: context and its role in the ARV project	The building was selected to replace the ITEA building in Area 2.	ECD
29.03.2023	<b>INTERNAL ACTORS</b> University of Trento, DICAM, via Mesiano 77, Trento	<b>EURAC</b> - dott. D. Vettorato <b>UNITN</b> - prof. R. Albatici <b>HABITECH</b> - dott. M. Curci - dott. M. Dell'Antonio <b>FANTI LEGNAMI S.R.L</b> M. Fanti	Application of the Renew Wall system on the Existing Building	During the meeting the participants discuss the planning of the refurbishment intervention of the building with with particular reference to the applications of the Renew wall panels.	ECD
12.04.2023	<b>INTERNAL ACTORS</b> University of Trento, DICAM, via Mesiano 77, Trento	<b>EURAC</b> - dott. D. Vettorato <b>UNITN</b> - prof. R. Albatici <b>HABITECH</b> - dott. M. Curci - dott. M. Dell'Antonio <b>FANTI LEGNAMI S.R.L</b> - M. Fanti	Application of the Renew Wall system on the Existing Building	During the meeting the participants define the planning of the refurbishment intervention of the building with with particular reference to the applications of the Renew wall panels and the implications in relation to the SUPERBONUS 110%.	ECD
12.04.2023	<b>USERS / CONDOMINIUM ASSEMBLY</b> Sala circoscrizione via Don T. Dallafior, 5 Povo (TN)	<b>UNITN</b> - prof. R. Albatici <b>SOVERCAR GROUP</b> - dott.. M. Giglioli <b>Residents of the building</b> - Administrator <b>A. Felicetti</b>	Presentation of ARV project and Trento demonstration site (contribute of R. Albatici)  Presentation of Refurbishment measures and general economic framework (contribute of M. Giglioli)	During the condominium meeting, the renovation and its implications in relation to the ARV project were explained.  During the condominium meeting, the renovation and its implications in relation to the SUPERBONUS 110% with the	ECD

		<ul style="list-style-type: none"> <li>- inhabitants who own the housing units.</li> </ul>		<p>technico-economic feasibility of the intervention were explained.</p> <p>During the condominium meeting the ReneWall system application has been introduced.</p>	
31/05/2023	<p><b>INTERNAL and EXTERNAL ACTORS</b></p> <p>“Condominio Pante”, in Pantè Street n.2, Povo (Trento)</p>	<p><b>EURAC</b></p> <ul style="list-style-type: none"> <li>- dott. D. Vettorato</li> </ul> <p><b>UNITN</b></p> <ul style="list-style-type: none"> <li>- prof. R. Albatici</li> <li>- ing. N. Callegaro</li> </ul> <p><b>HABITECH</b></p> <ul style="list-style-type: none"> <li>- dott. M. Curci</li> </ul> <p><b>FANTI LEGNAMI S.R.L</b></p> <ul style="list-style-type: none"> <li>- arch. G. Zini</li> </ul> <p><b>USERS</b></p> <ul style="list-style-type: none"> <li>- Condominium administrator</li> <li>- Residents of the building</li> </ul>	<p>Installation of the Renew Wall panels</p> <p>Strategies and requirements of the monitoring activities</p> <p>Postion of the sensors monitoring in the panels</p> <p>Postion of the environmental monitoring sensors</p>	<p>During this on-site meeting, users were again informed and interviewed in order to gather useful information to define the goals and the design of the monitoring activities.</p>	ECD
05/07/2023	<p><b>INTERNAL and EXTERNAL ACTORS</b></p> <p>“Condominio Pante”, in Pantè Street n.2, Povo (Trento)</p>	<p><b>EURAC</b></p> <ul style="list-style-type: none"> <li>- dott. G. Grazieschi</li> <li>- dott. D. Cennamo</li> </ul> <p><b>UNITN</b></p> <ul style="list-style-type: none"> <li>- ing. G. Maracchini</li> </ul> <p><b>USERS</b></p> <ul style="list-style-type: none"> <li>- Condominium administrator</li> <li>- Residents of the building</li> </ul>	<p>Consumption and Envelope monitoring activities</p>	<p>During this on-site meeting the consumption monitoring and envelope monitoring has been refined with discussion on the installation offsite and onsite, and data collection.</p>	ECD
02/08/2023	<p><b>INTERNAL and EXTERNAL ACTORS</b></p> <p>Malosco (TN)</p>	<p><b>UNITN</b></p> <ul style="list-style-type: none"> <li>- prof. R. Albatici</li> </ul> <p><b>FANTI LEGNAMI S.R.L</b></p> <ul style="list-style-type: none"> <li>- arch. G. Zini</li> </ul>	<p>Envolpe performance monitoring: devices and installation</p>	<p>The installation of surface temperature and thermo-flux sensors in the Renew Wall panel has been performed.</p>	DD
31/08/2023	<p><b>INTERNAL and EXTERNAL ACTORS</b></p>	<p><b>LEVA S.R.L.</b></p> <ul style="list-style-type: none"> <li>- ing. Veronesi</li> </ul>	<p>Organization of the construction site</p>	<p>During this on-site meeting the installation of surface temperature and thermo-flux sensors in the traditional external</p>	DeD

	<p>“Condominio Pante”, in Pantè Street n.2, Povo (Trento)</p>	<p><b>UNITN</b></p> <ul style="list-style-type: none"> <li>- prof. R. Albatici</li> <li>- prof. M.Dalprà</li> <li>- ing. S. Torresin</li> </ul>	<p>Envolpe performance monitoring: devices and installation</p> <p>Acoustic performance of the construction site: timing and involvement the Users</p>	<p>insulation and finishing system has been scheduled. In addition, the acoustic monitoring of the construction site has been planned. Resident users, in fact will be interviewed during site work.</p>	
1/09/2023	<p><b>EXTERNAL ACTORS</b></p> <p>“Condominio Pante”, in Pantè Street n.2, Povo (Trento)</p>	<p><b>LEVA S.R.L.</b></p> <ul style="list-style-type: none"> <li>- ing. Veronesi</li> </ul> <p><b>FANTI LEGNAMI S.R.L</b></p> <ul style="list-style-type: none"> <li>- arch. G. Zini</li> </ul> <p><b>USERS</b></p> <ul style="list-style-type: none"> <li>- Condominium administrator</li> <li>- Residents of the building</li> </ul>	<p>Interventions for improving architectural quality of the building</p>	<p>During this on-site meeting the participants discuss and define the architectural interventions on private parts (colour of the building and roller shutters, balcony railing, etc.) in order to improve the architectural quality of the building.</p>	DeD





CLIMATE POSITIVE CIRCULAR COMMUNITIES

## ANNEX

### 9.3.10 Refurbishment programme of the Existing Building

D4.5 DESIGN GUIDELINES OF CLIMATE POSITIVE CIRCULAR COMMUNITY IN TRENTO

WP4 SUSTAINABLE BUILDING (RE) DESIGN

# Miglioramenti



Miglioramento energetico



Miglioramento del comfort abitativo



Ammodernamento estetico



Nuovo valore economico

- Condominio: **Condominio Pantè**
- Località: Povo (TN)
- N° unità abitative: 8
- Interventi riconducibili a Superbonus 110%, parti comuni:
  - Cappotto termico:  
**SISTEMA TRADIZIONALE + SISTEMA RENEW-WALL**
  - Coibentazione solaio soffitta
  - Coibentazione solaio cantine (da verificare fattibilità)
  - Impianto fotovoltaico condominiale con accumulo



# SISTEMA CAPPOTTO TRADIZIONALE

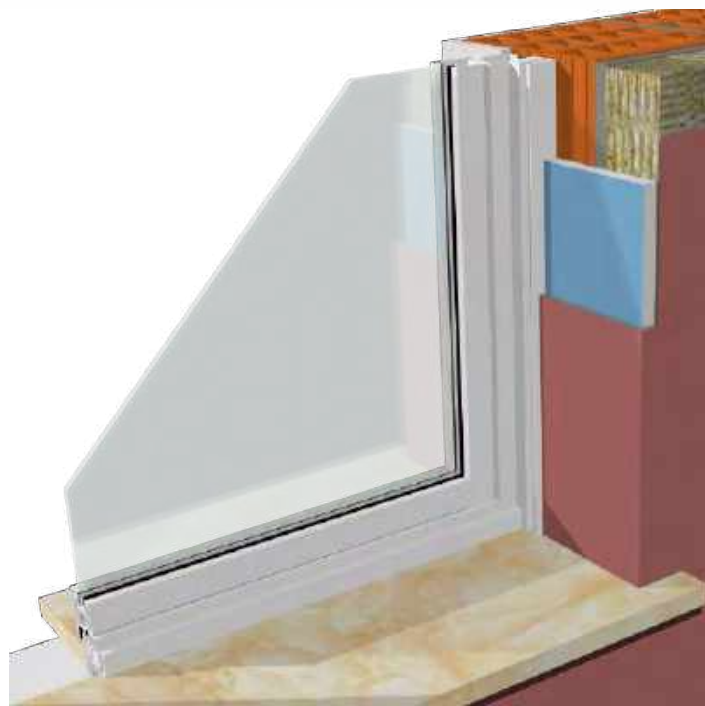


Lana di vetro

EPS bianco e grigio

Resina fenolica

Sughero



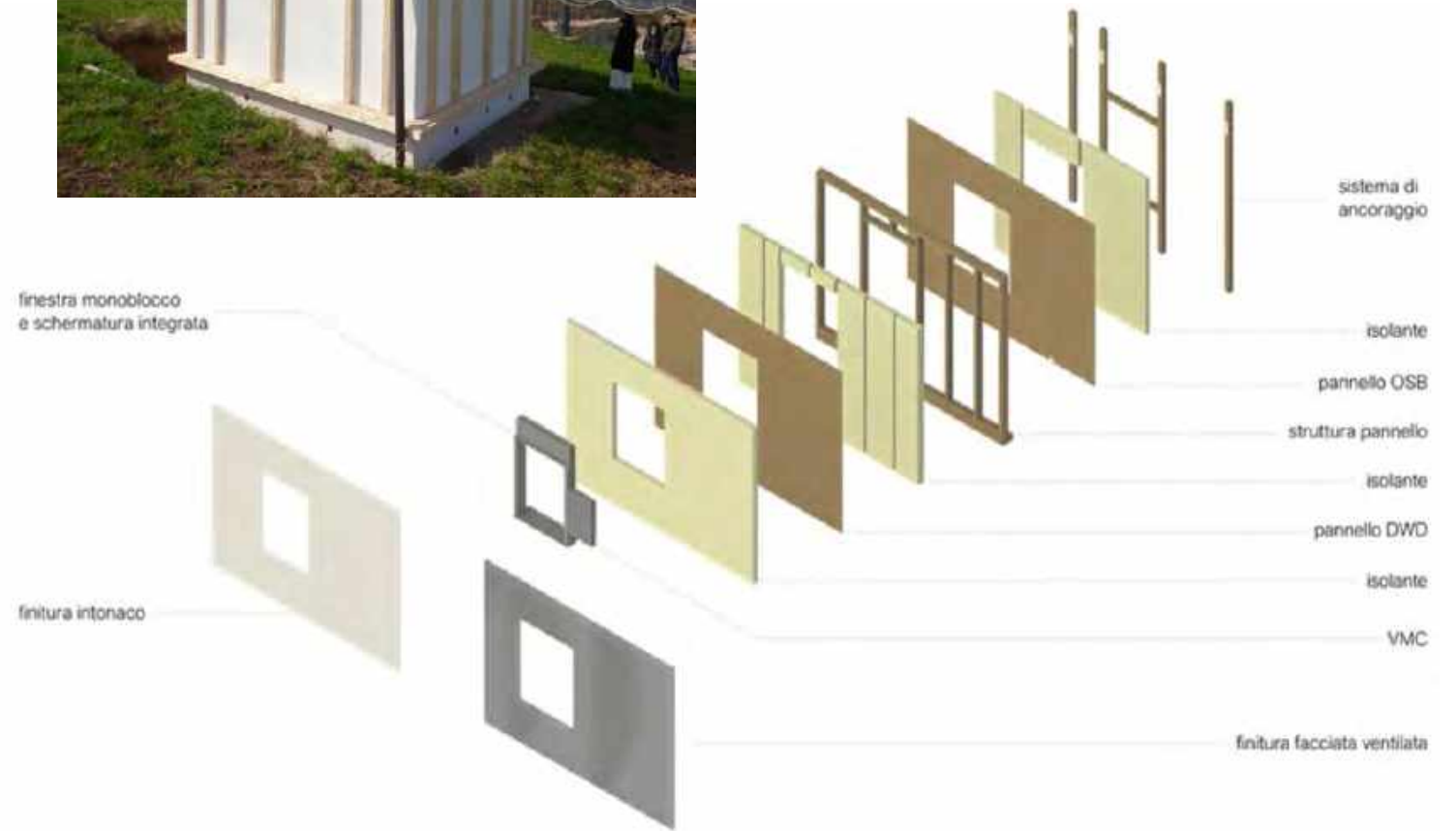
# INTERVENTI TRAINANTI



Aerogel

# SISTEMA CAPPOTTO RENEW-WALL

INTERVENTI TRAINANTI





# INTERVENTI TRAINANTI

PRIMA



NUOVO TERMOBANCALE IN GRESS



DOPO





**PARTI PRIVATE: TENDE DA SOLE, ANTENNE TV, STENDI PANNI, PORTA FIORI**



**SMONTAGGIO, CUSTODIA  
E SUCCESSIVO  
RIMONTAGGIO A CARICO  
DEL PROPRIETARIO.**

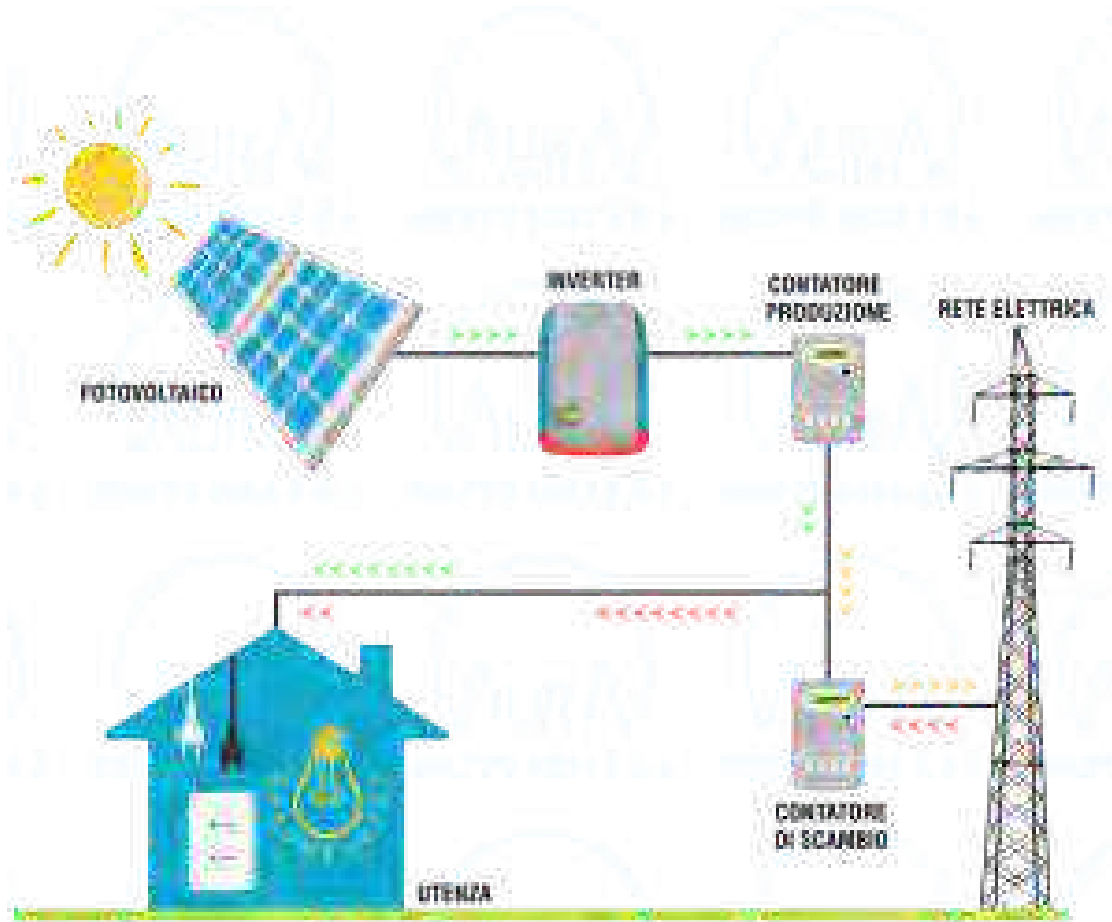
# **PARTI PRIVATE: TENDE DA SOLE, ANTENNE TV, STENDI PANNI, PORTA FIORI**



**SMONTAGGIO, CUSTODIA  
E SUCCESSIVO  
RIMONTAGGIO A CARICO  
DEL PROPRIETARIO.**



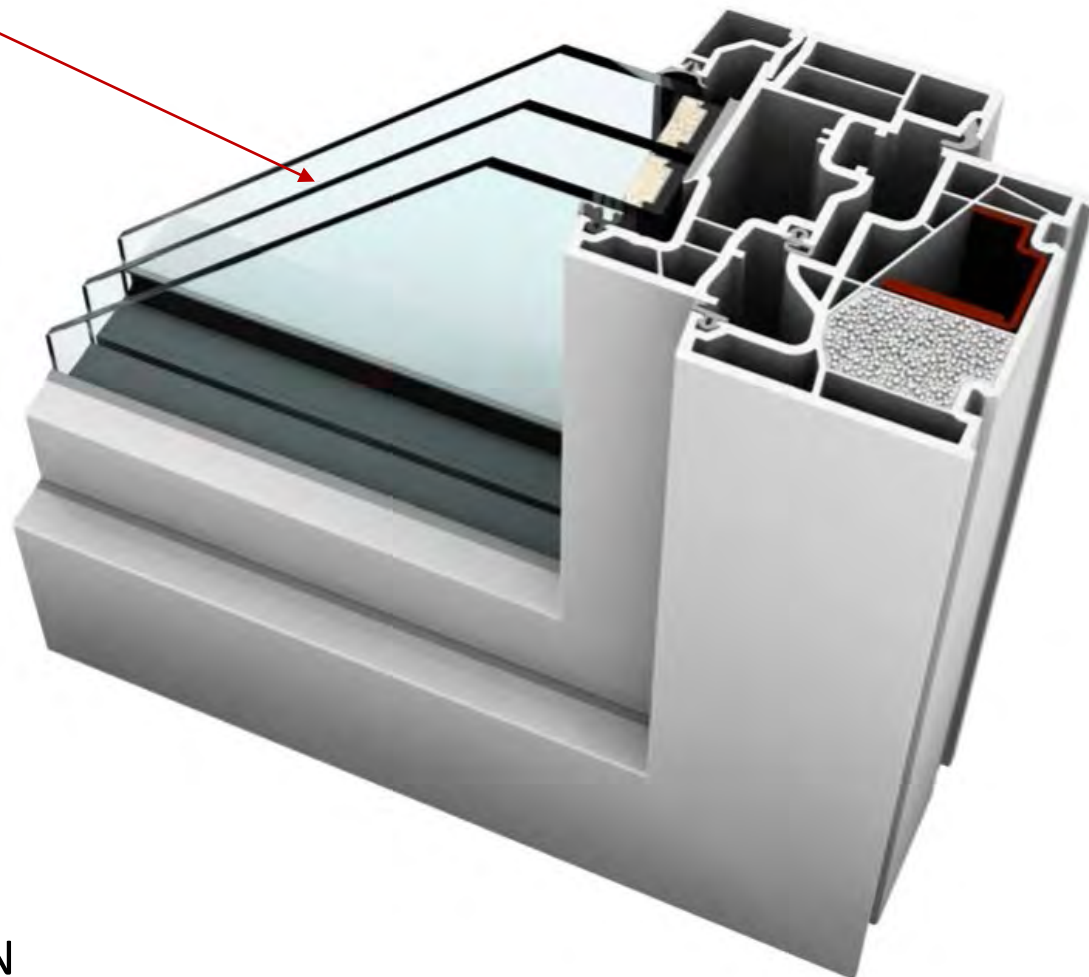
# *PARTI COMUNI:* IMPIANTO FOTOVOLTAICO CONDOMINIALE



# PARTI PRIVATE: SERRAMENTI

INTERVENTI TRAINATI

TRIPLO VETRO



MANIGLIA  
STANDARD IN  
ALLUMINIO

SERRAMENTI CON FINITURA  
INTERNA ED ESTERNA IN PVC  
COLOR BIANCO.  
TAPPARELLE IN ALLUMINIO.  
ISOLAZIONE DEL CASSONETTO.

**INTERVENTO POSSIBILE PER  
TUTTI GLI APPARTAMENTI**

*Immagini puramente indicative*

## PARTI PRIVATE: PORTONCINI BLINDATI TERMICI



Immagine indicativa

POSSIBILITA' DI SOSTITUZIONE DEL PORTONCINO DI INGRESSO CON NUOVO BLINDATO AVENTE CARATTERISTICHE TERMICHE PER ZONA CLIMATICA E SUPERBONUS 110%

**EXTRA COSTO € 580,00 iva compresa**



## *PARTI PRIVATE:* CENTRALE TERMICA

INTERVENTI TRAINATI



POSSIBILITÀ DI SOSTITUZIONE DELLA CENTRALE TERMICA CON NUOVO SISTEMA IBRIDO O NUOVA CALDAIA A CONDENSAZIONE

**EXTRA COSTO € 450,00 iva compresa**

INTERVENTI TRAINATI 50%

SERRAMENTI SU PARTI COMUNI NON  
RISCALDATE RIENTRANTI NEL BONUS  
**RISTRUTTURAZIONI 50%**

**NO SCONTO IN FATTURA**



Sostituzione serramenti giroscale  
(finestre e porta ingresso)

# INTERVENTI TRAINATI



**PITTURA DEL SOTTOGRONDA E DEL SOTTO POGGIOLI NON RIENTRANTI NEL SUPERBONUS MA COMPRESI NEI COSTI DELL'INTERVENTO**

# QUADRO ECONOMICO CONDOMINIO PANTÈ POVO

	Cognome	Millesimi	Quota per parti comuni
1	Miori	139,30000	10.436,16 €
2	Pepponi	139,30000	10.436,16 €
3	Andreatta	139,30000	10.436,16 €
4	Tomedi	112,90000	8.458,31 €
5	Bragagna	112,90000	8.458,31 €
6	Parisi	112,90000	8.458,31 €
7	Maestrelli	82,20000	6.158,31 €
8	ITEA	82,20000	5.355,05 €
9	Zancanelli	82,20000	6.158,31 €
	<b>TOTALE</b>	<b>1003,200</b>	<b>74.355,05 €</b>

<b>PARTI PRIVATE</b>	<b>cad o mt.</b>
PORTONCINO BLINDATO E TERMICO INGRESSO APPARTAMENTO	<b>580,00 €</b>
CENTRALE TERMICA CON SISTEMA IBRIDO o NUOVA CALDAIA	<b>450,00 €</b>
<b>PARTI COMUNI AL 50% (no sconto in fattura)</b>	
SOSTITUZIONE SERRAMENTI VANO SCALE E PORTA INGRESSO	<b>14 000,00 €</b>



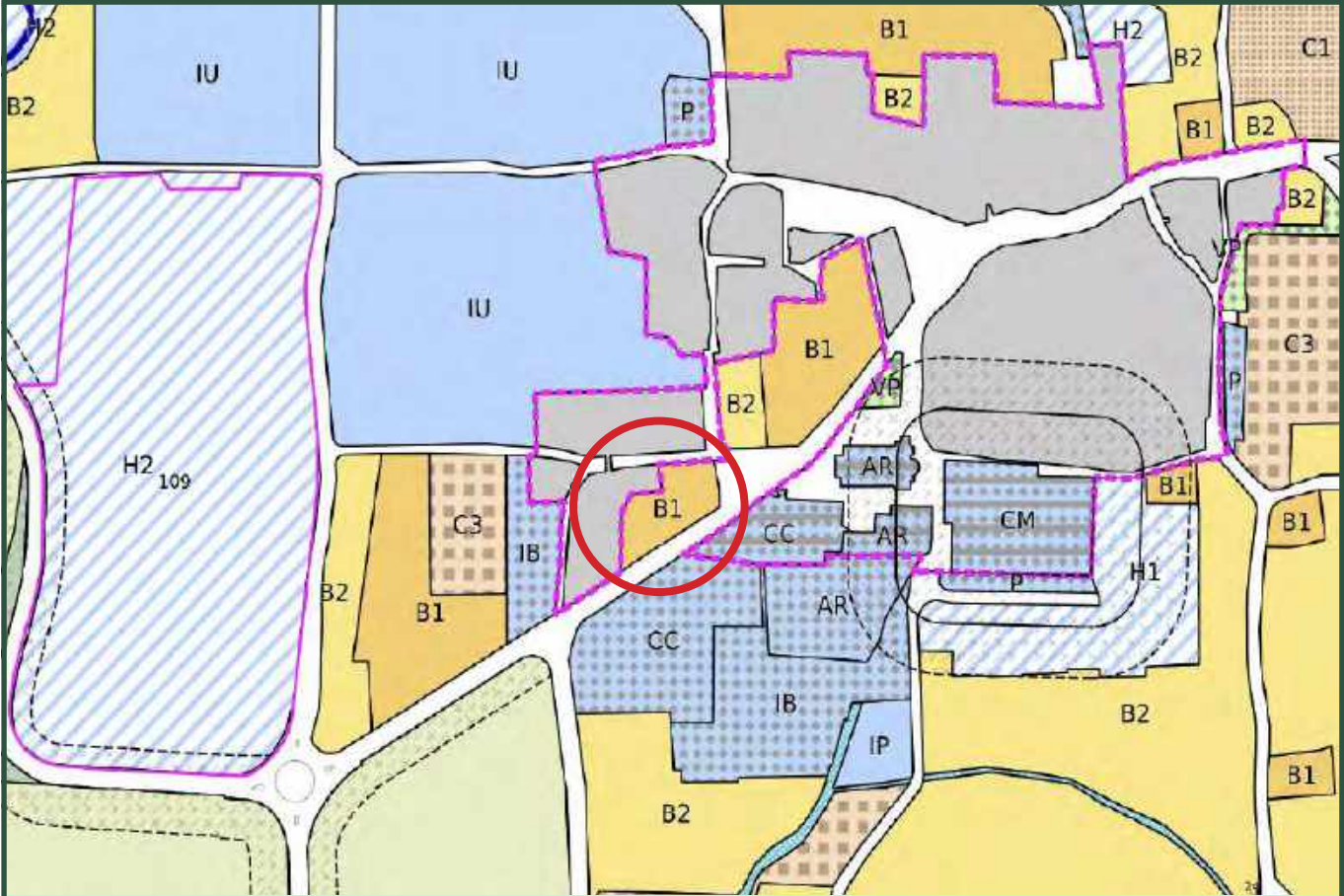


CLIMATE POSITIVE CIRCULAR COMMUNITIES

## **ANNEX**

### **9.3.11 Visual inspection and existing documentation**

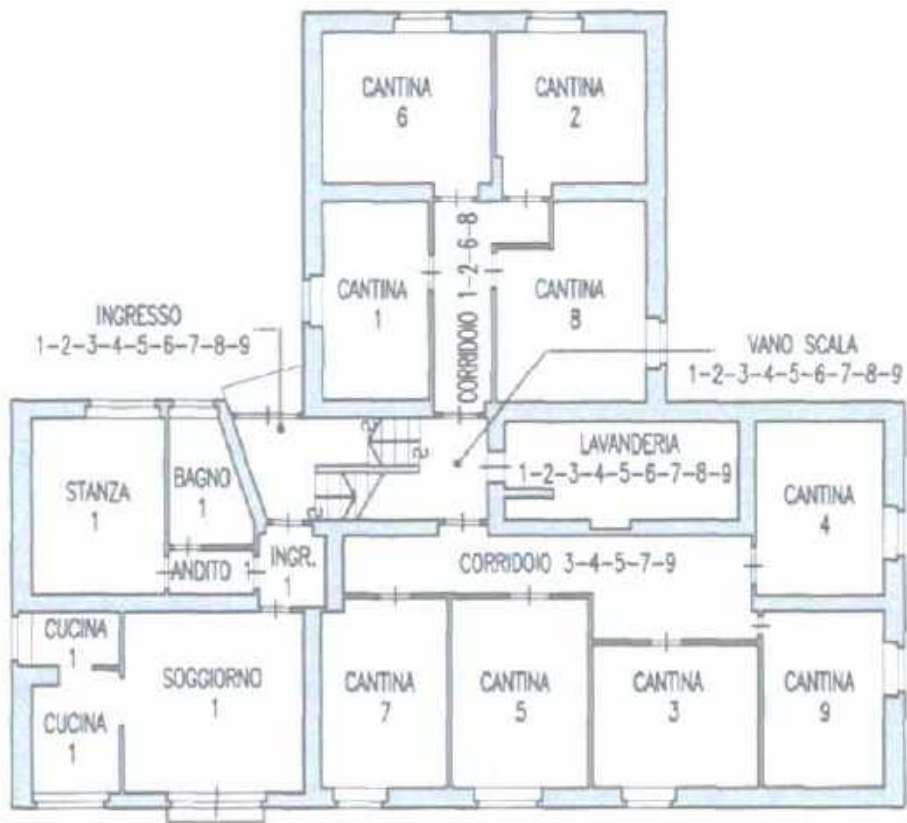




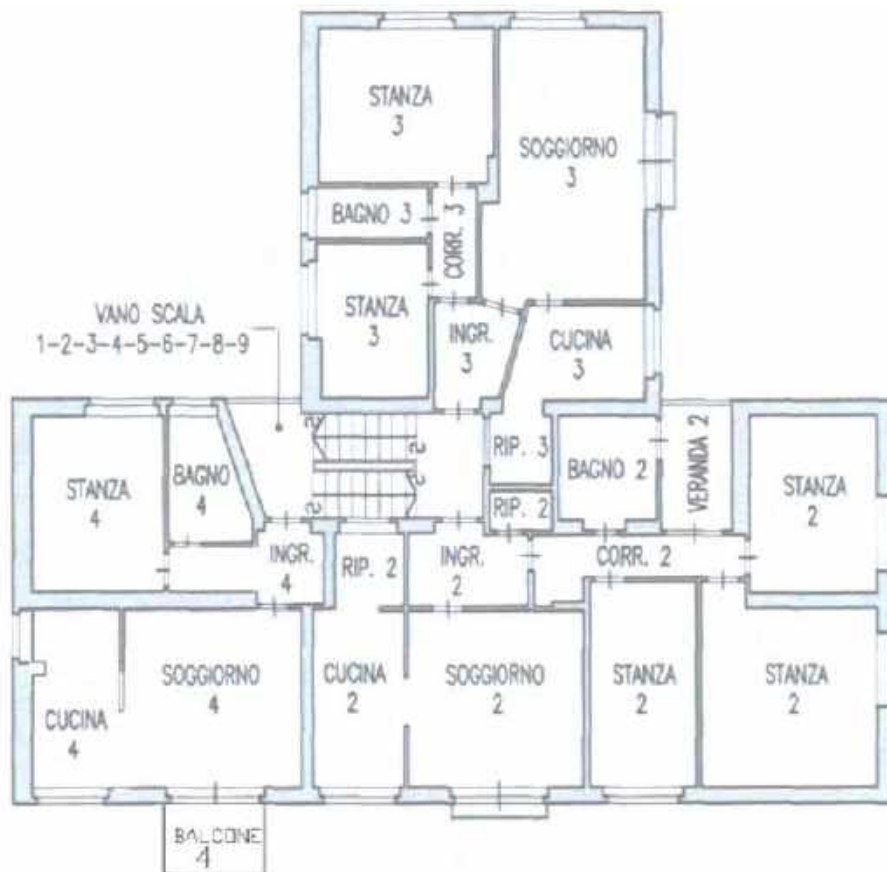
Town Plan extracted



Ortophoto of Povo district (Trento)

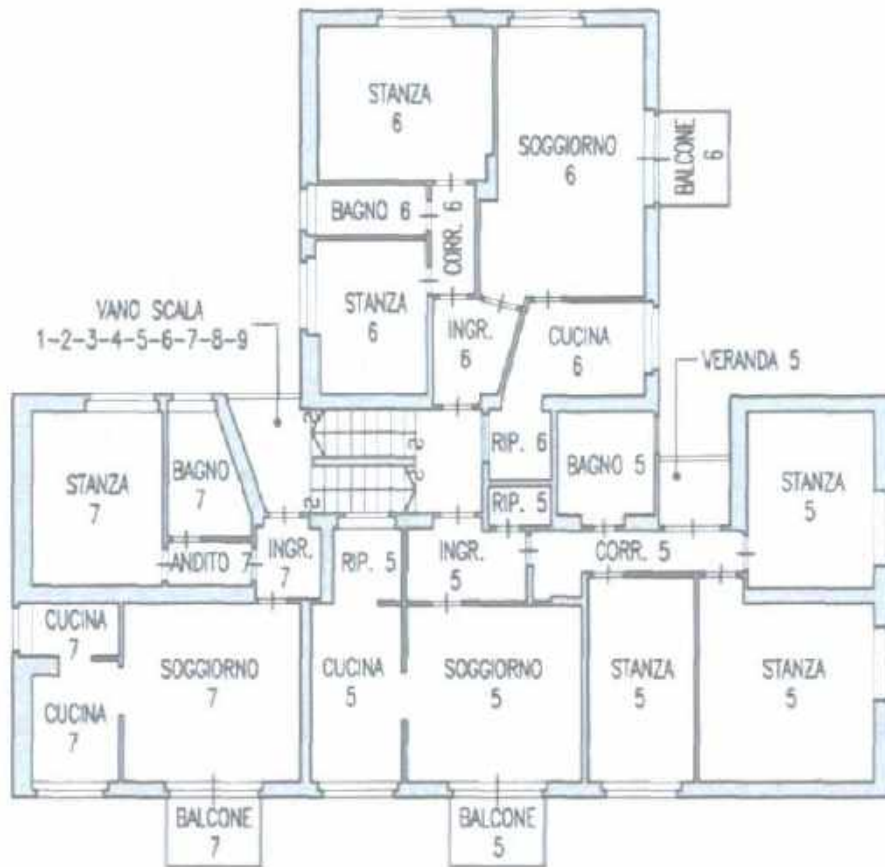


Underground floor

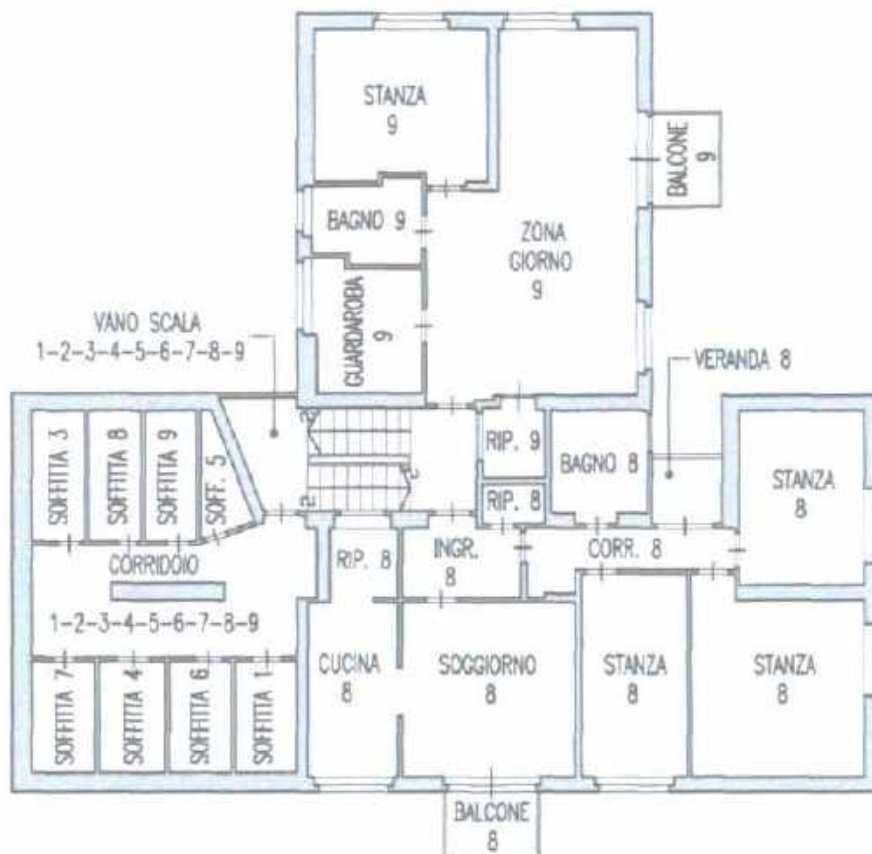


Ground floor

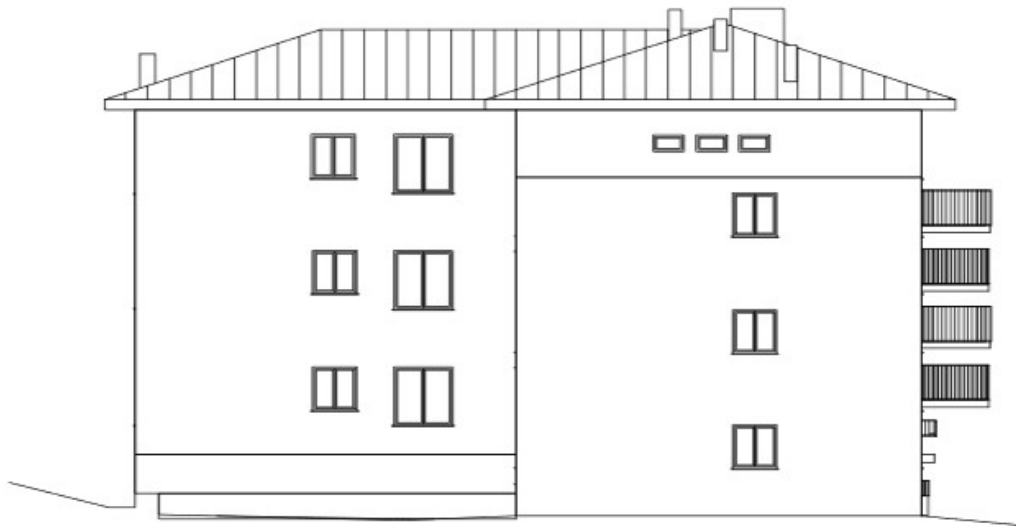




First floor



Second floor



North - West elevation



North - Est elevation



South - East elevation



South - West elevation



















CLIMATE POSITIVE CIRCULAR COMMUNITIES

## **ANNEX**

### 9.3.12 Thermographic survey for the Refurbishment

D4.5 DESIGN GUIDELINES OF CLIMATE POSITIVE CIRCULAR COMMUNITY IN TRENTO

WP4 SUSTAINABLE BUILDING (RE) DESIGN





***Thermographic survey of an apartment building  
Via Pantè – Povo (Trento – Italy)  
May 2023***

ARV project

*R. Albatici  
University of Trento – Department of Civil Environmental and Mechanical Engineering*

## Equipment:

- thermal camera Avio R340
- wavelength range:  $8 \div 14 \mu\text{m}$  (seconda “finestra atmosferica”)
- angle of view:  $24^\circ \times 18^\circ$  (480 x 360 pixels)
- spatial resolution: 0.87 mrad
- thermal sensitivity:  $0.025^\circ \text{C}$
- temperature measurement range:  $-40/+ 650^\circ \text{C}$
- detector type: FPA microbolometer VOx – dual layer



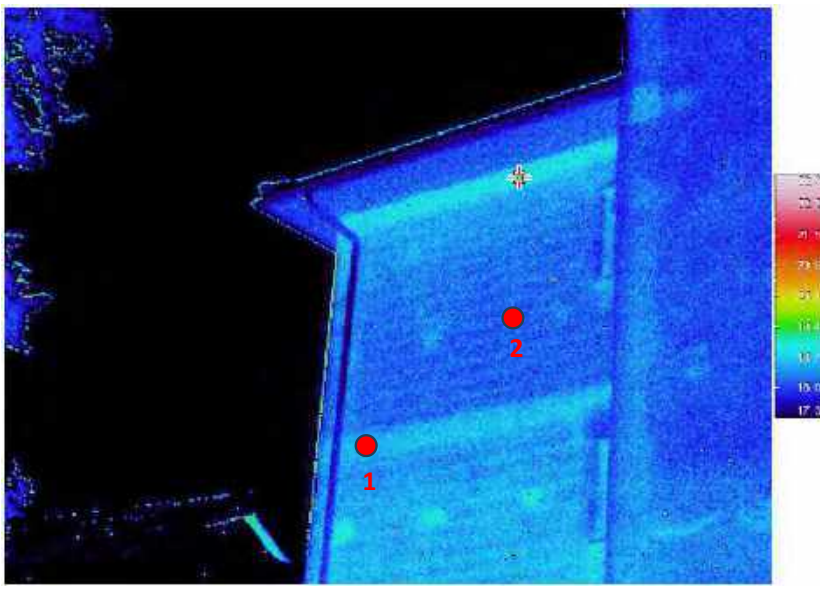
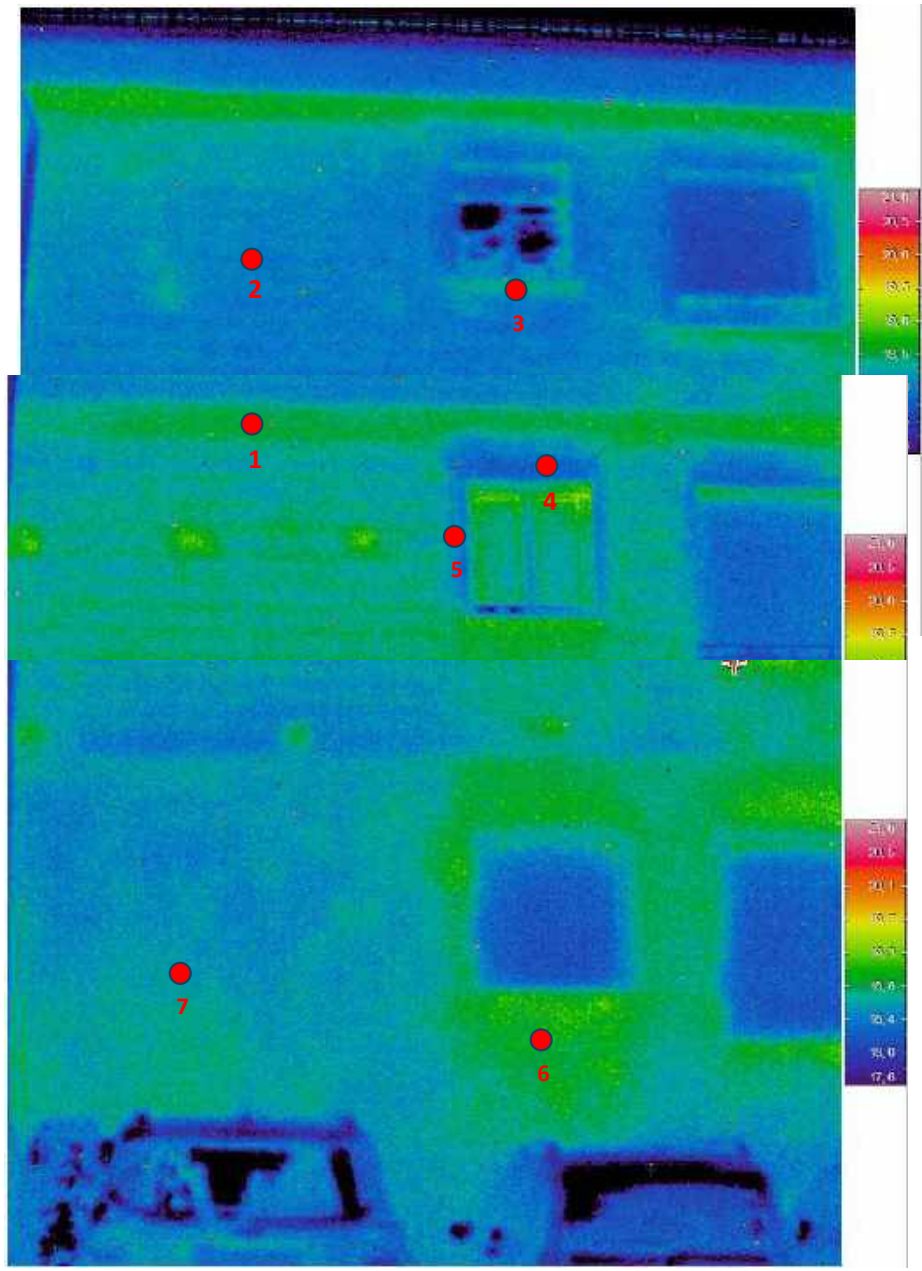
## Environmental conditions:

- 17<sup>th</sup> May 2023
- outdoor temperature: between  $17/18^\circ \text{C}$
- indoor temperature: between  $22.5/23.0^\circ \text{C}$
- surface emissivity outer layer : 0.95 (value from table for external plaster in the defioned wavelength range)
- time: 10.00-11.00 pm

**NORTH FACADE**



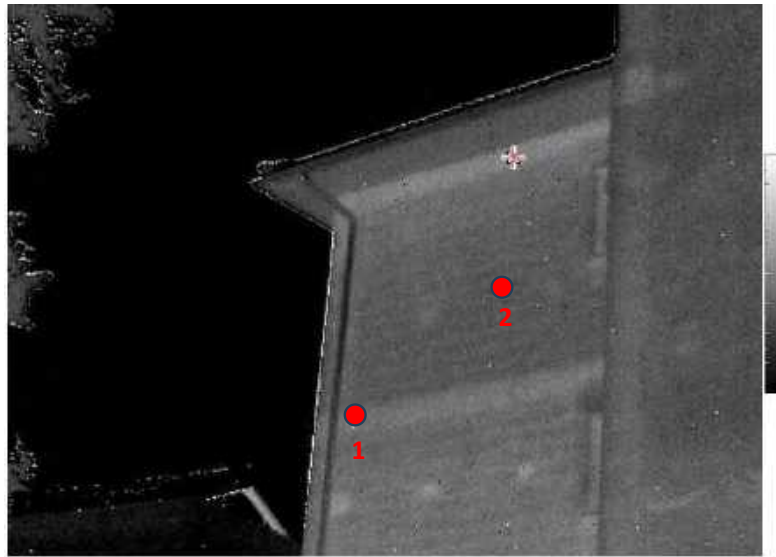
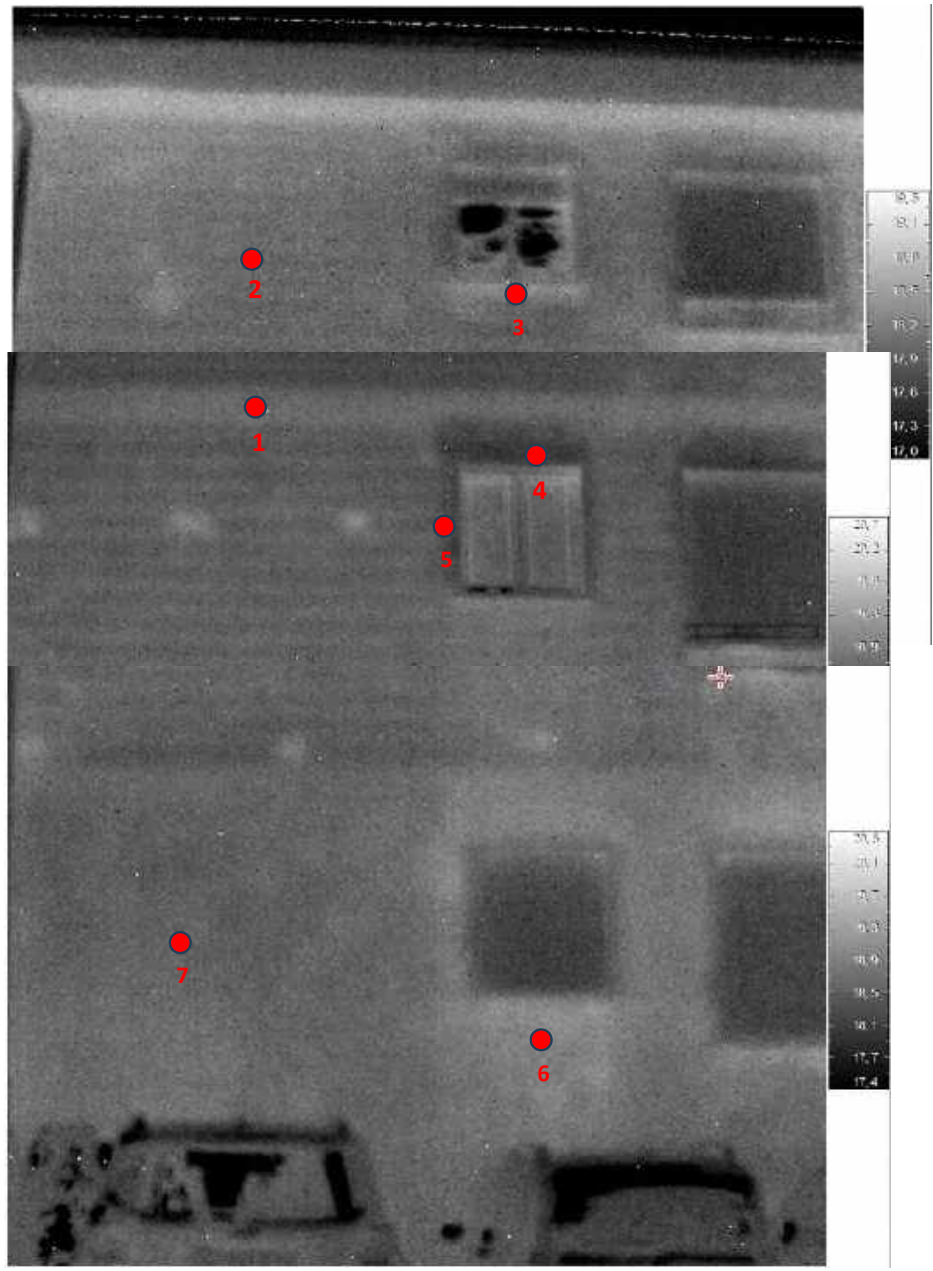
**North-East**



- 1. Thermal bridges due to concrete kerbs
- 2. Brick block masonry
- 3. Thermal bridges of the window sill
- 4. Thermal bridges of the window lintel
- 5. Thermal bridges of the window reveal
- 6. Radiators
- 7. Natural stone masonry



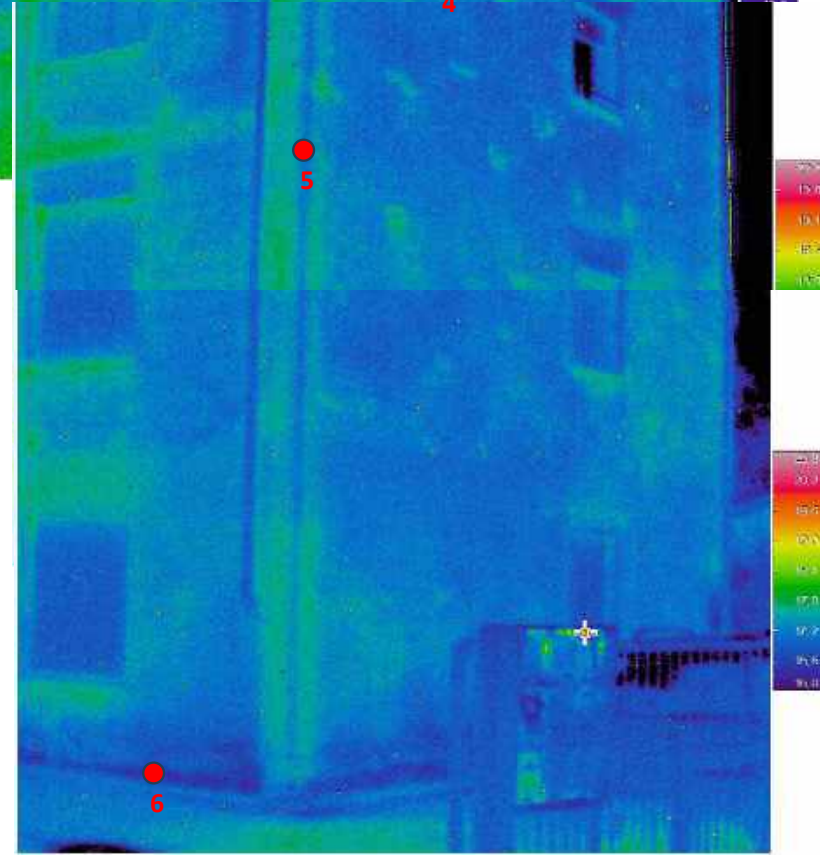
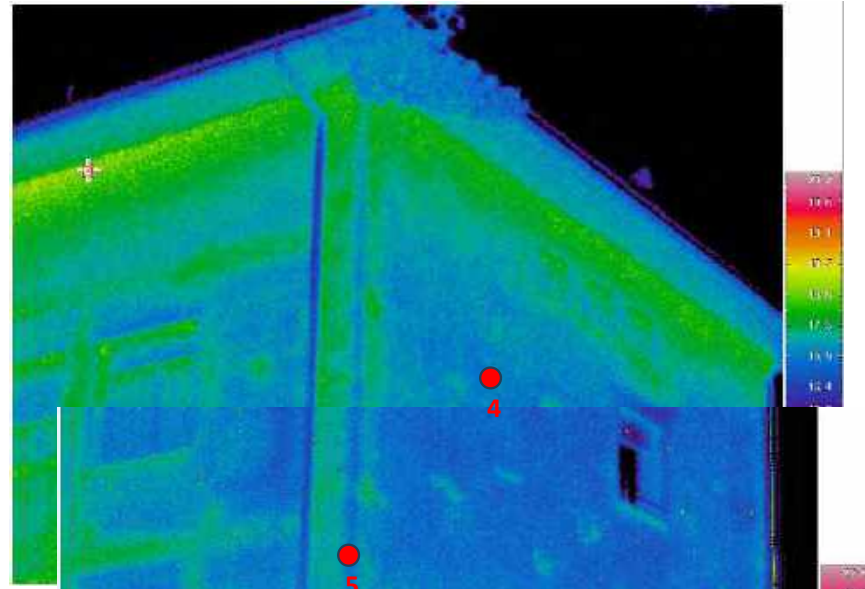
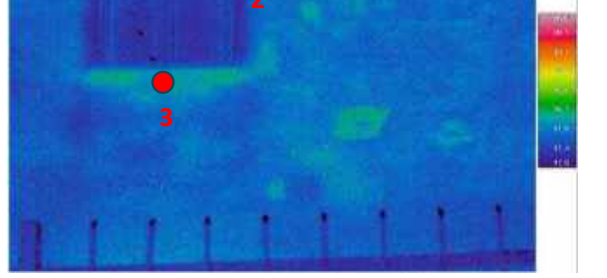
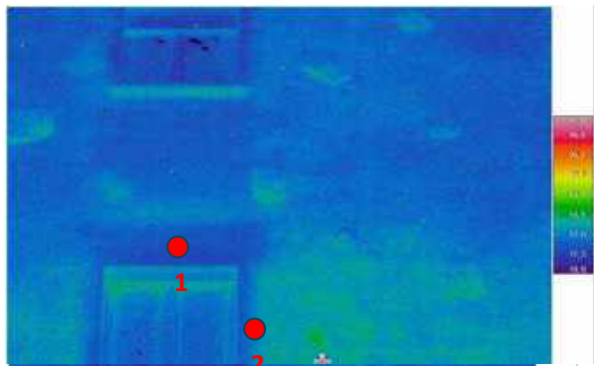
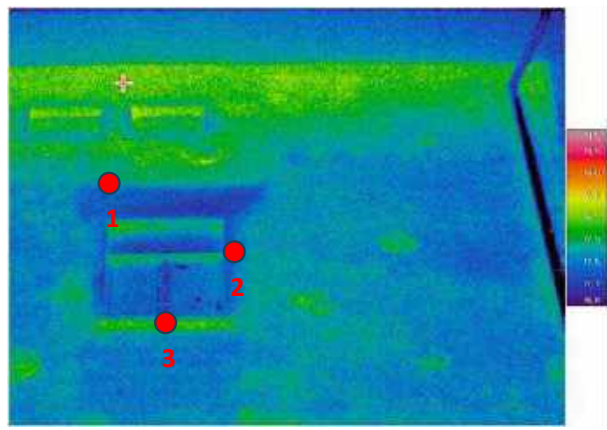
**North-East**



- 1. Thermal bridges due to concrete kerbs
- 2. Brick block masonry
- 3. Thermal bridges of the window sill
- 4. Thermal bridges of the window lintel
- 5. Thermal bridges of the window reveal
- 6. Radiators
- 7. Natural stone masonry

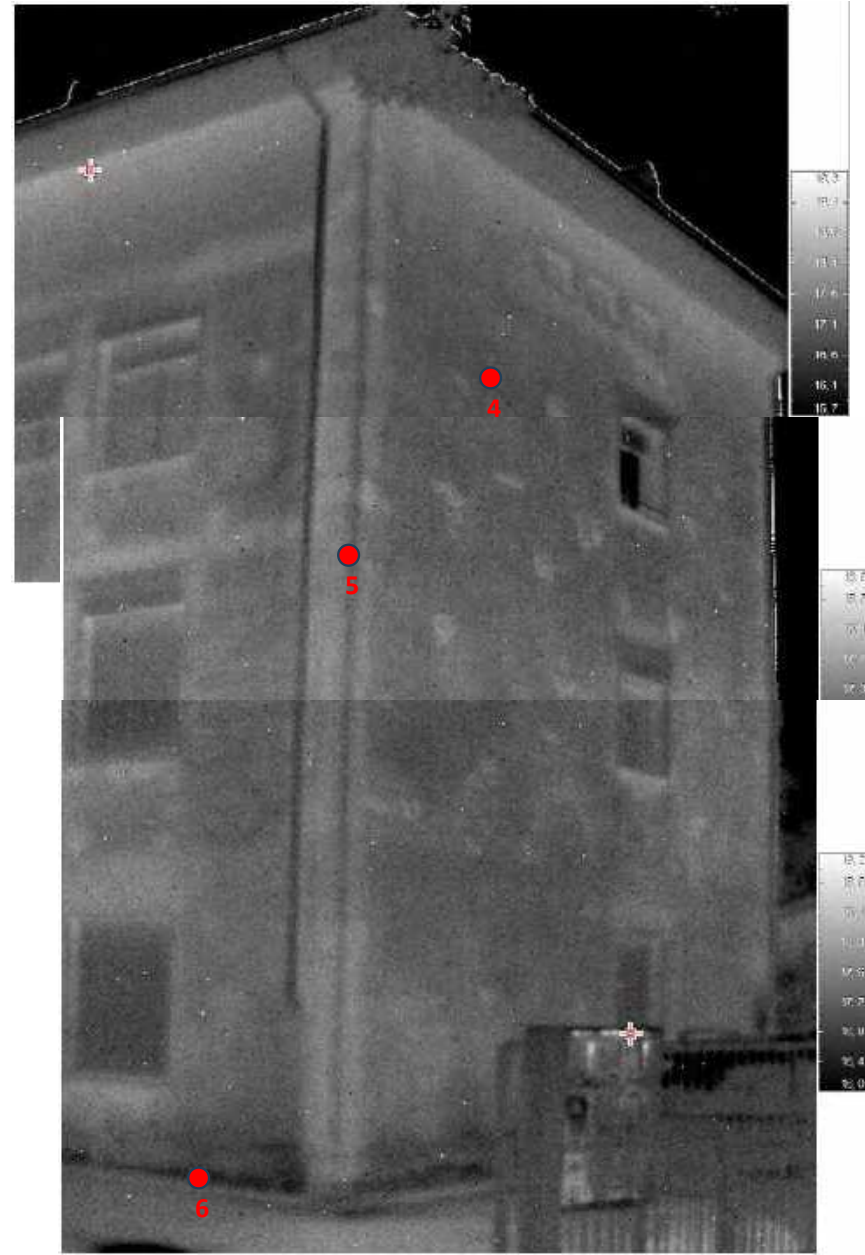
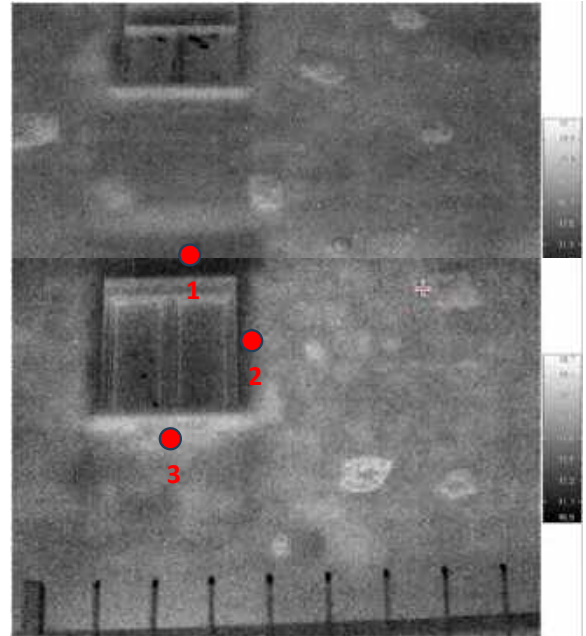
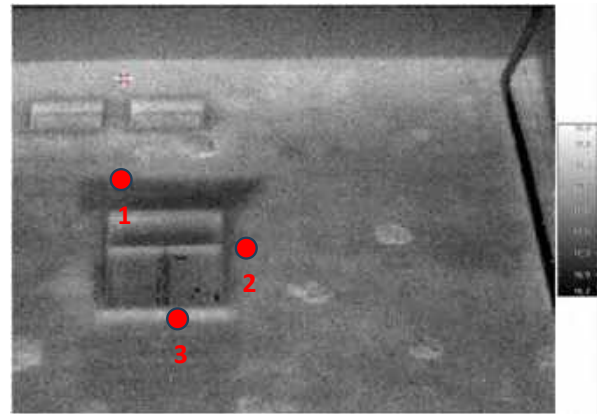


**North-West**



- 1. Thermal bridges of the window lintel
- 2. Thermal bridges of the window reveal
- 3. Thermal bridges of the window sill
- 4. Natural stone masonry
- 5. Thermal bridges due to masonry edge
- 6. Probable capillary rising damp

**North-West**



- 1. Thermal bridges of the window lintel
- 2. Thermal bridges of the window reveal
- 3. Thermal bridges of the window sill
- 4. Natural stone masonry
- 5. Thermal bridges due to masonry edge
- 6. Probable capillary rising damp



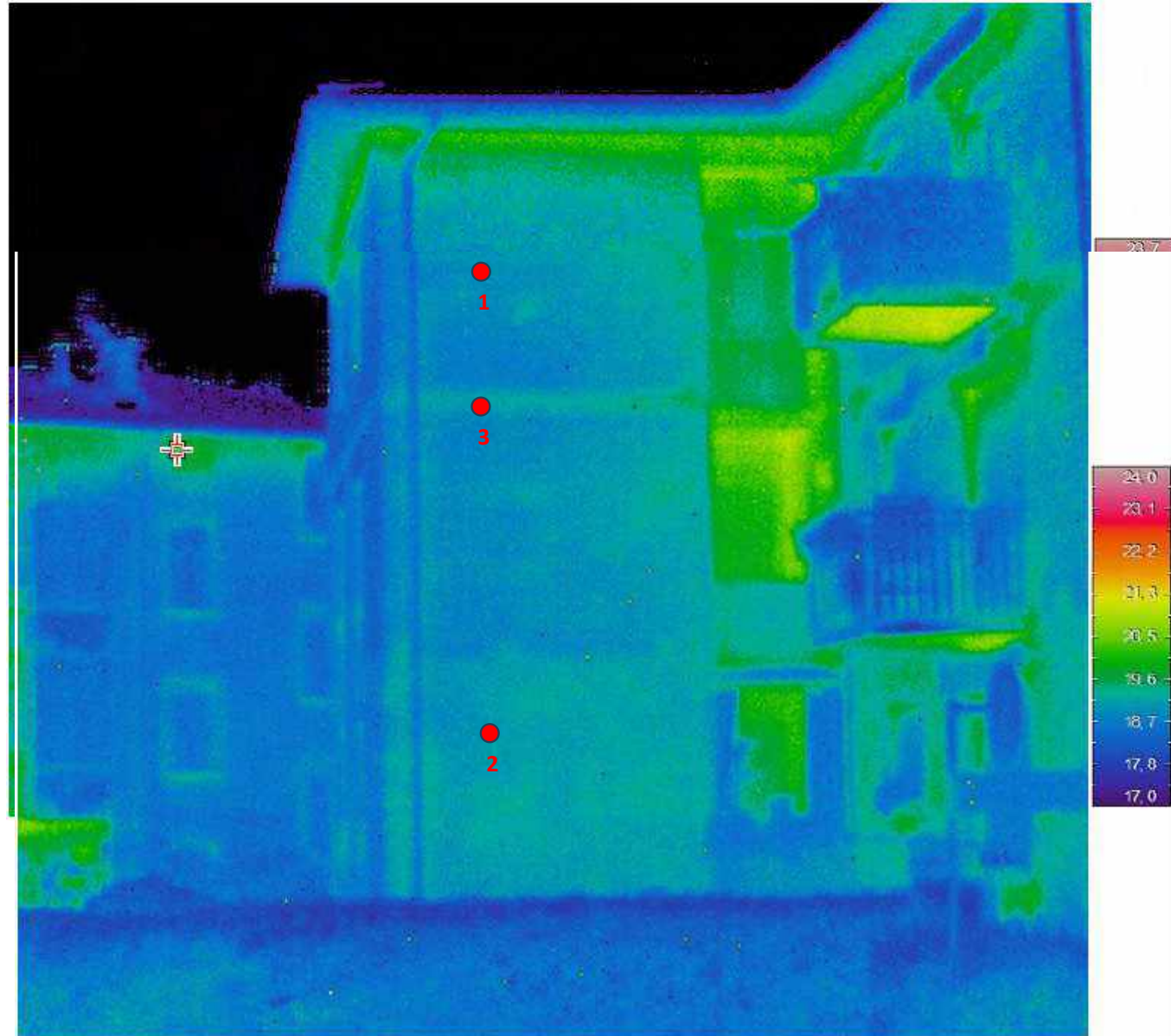
**EAST FACADE**



## East-South



1. Brick block masonry
2. Natural stone masonry
3. Thermal bridges due to masonry kerbs





## East-South



1. Brick block masonry
2. Natural stone masonry
3. Thermal bridges due to masonry kerbs

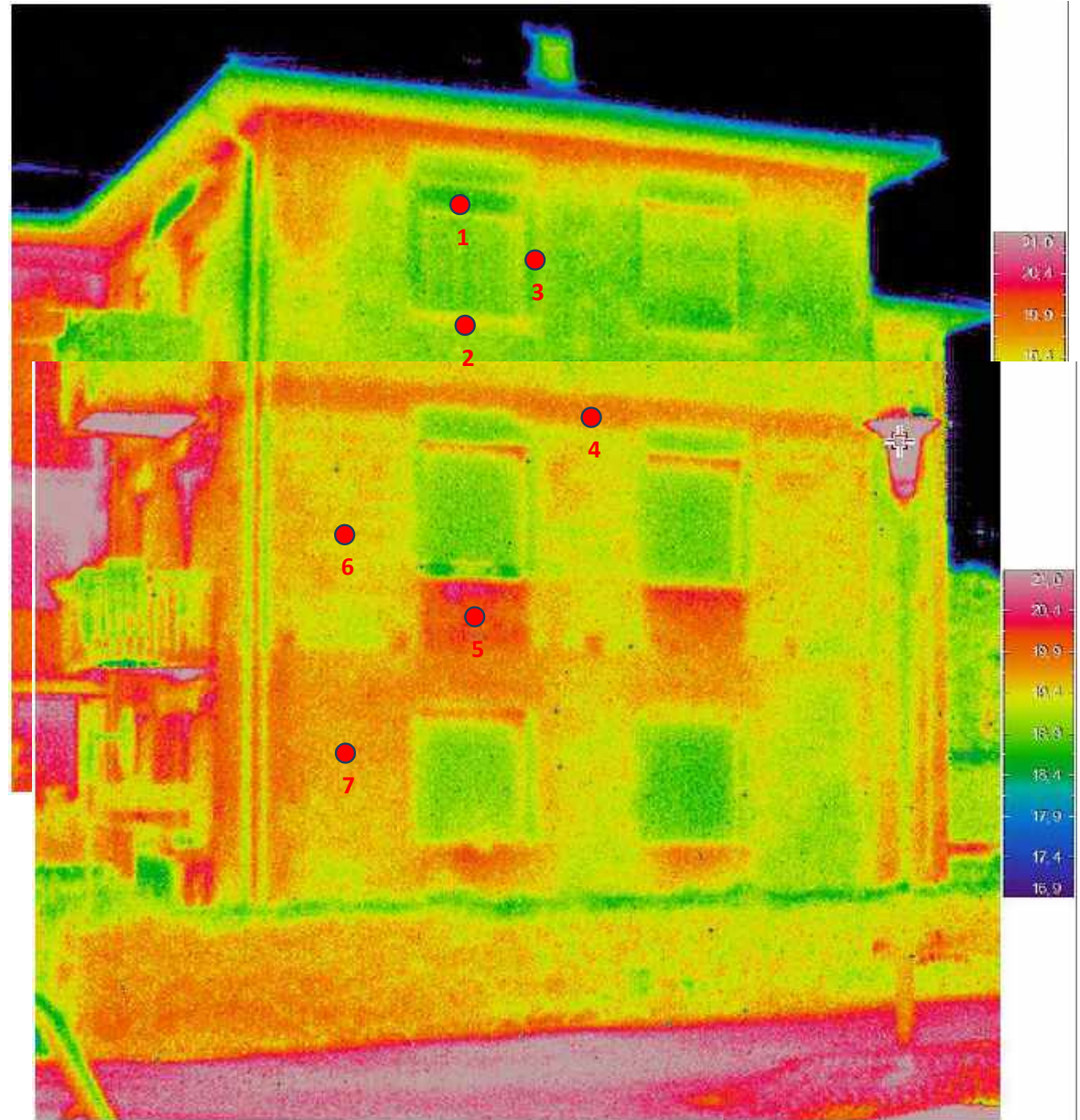




## East



1. Thermal bridges of the window lintel
2. Thermal bridges of the window reveal
3. Thermal bridges of the window sill
4. Thermal bridges due to concrete kerbs
5. Radiators
6. Brick block masonry
7. Natural stone masonry



## East

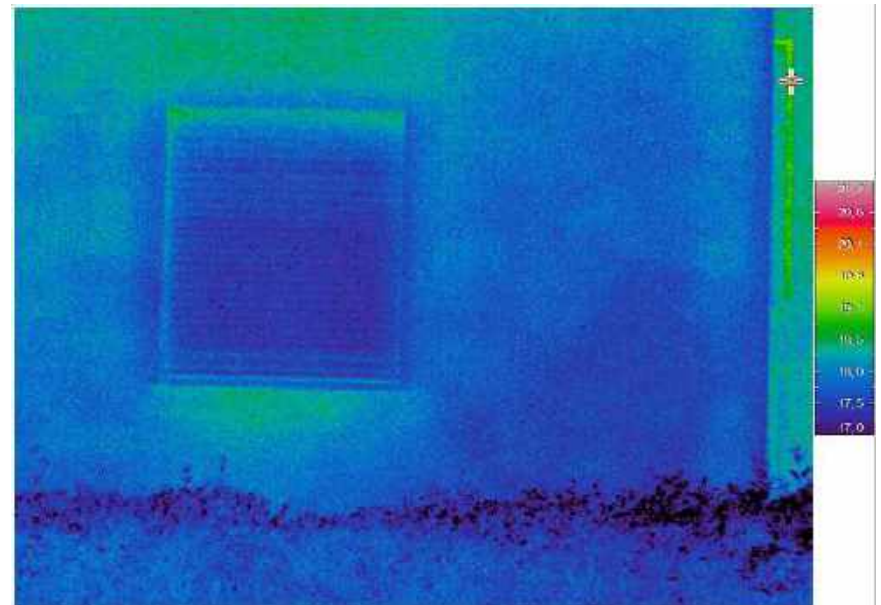
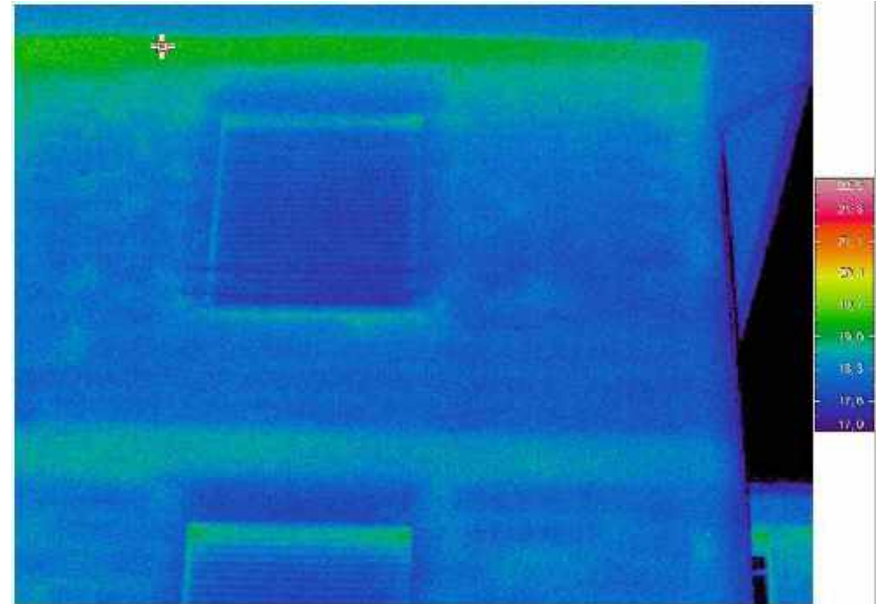
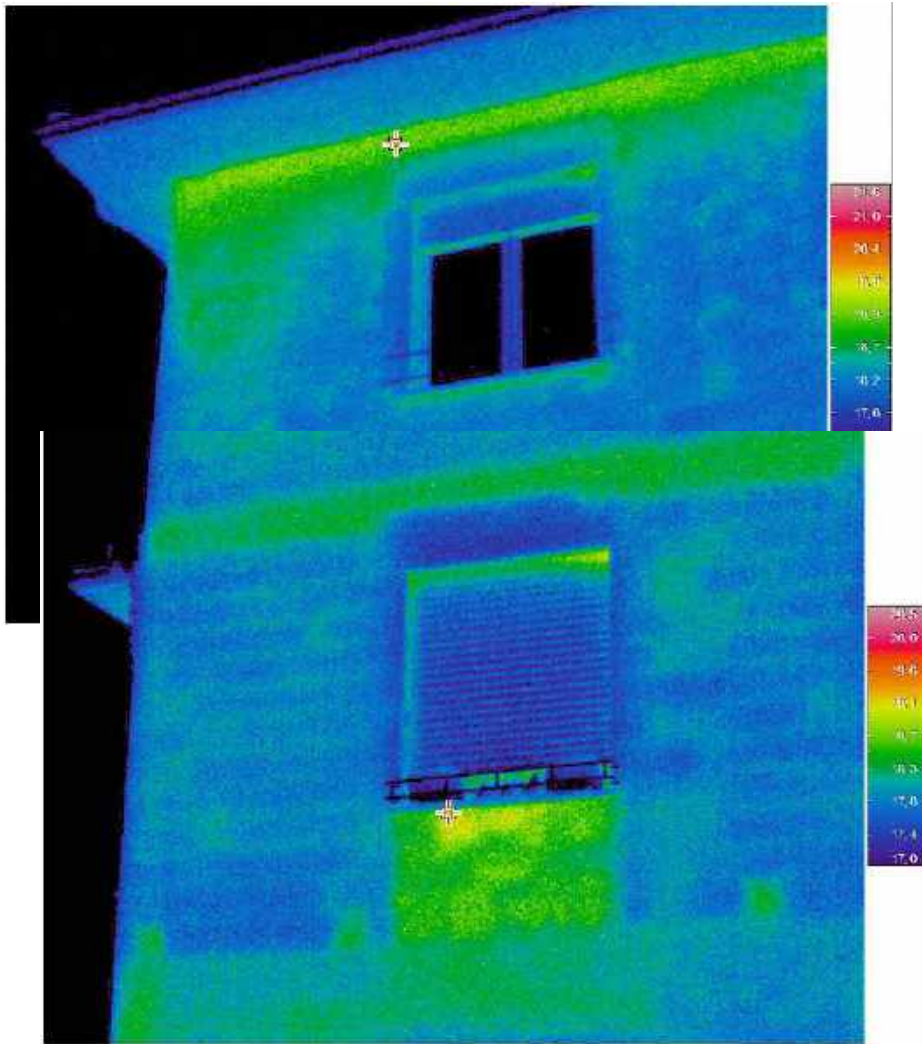


1. Thermal bridges of the window lintel
2. Thermal bridges of the window reveal
3. Thermal bridges of the window sill
4. Thermal bridges due to concrete kerbs
5. Radiators
6. Brick block masonry
7. Natural stone masonry

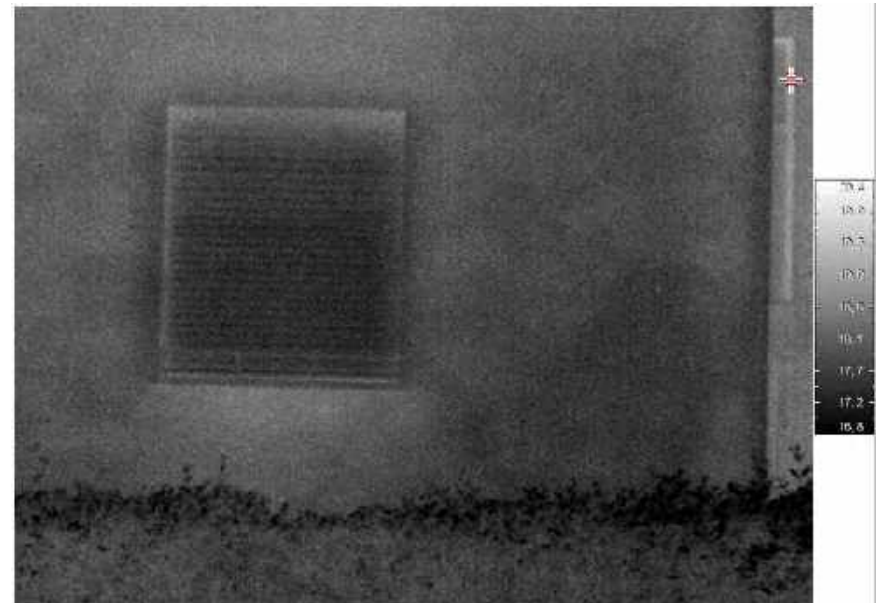
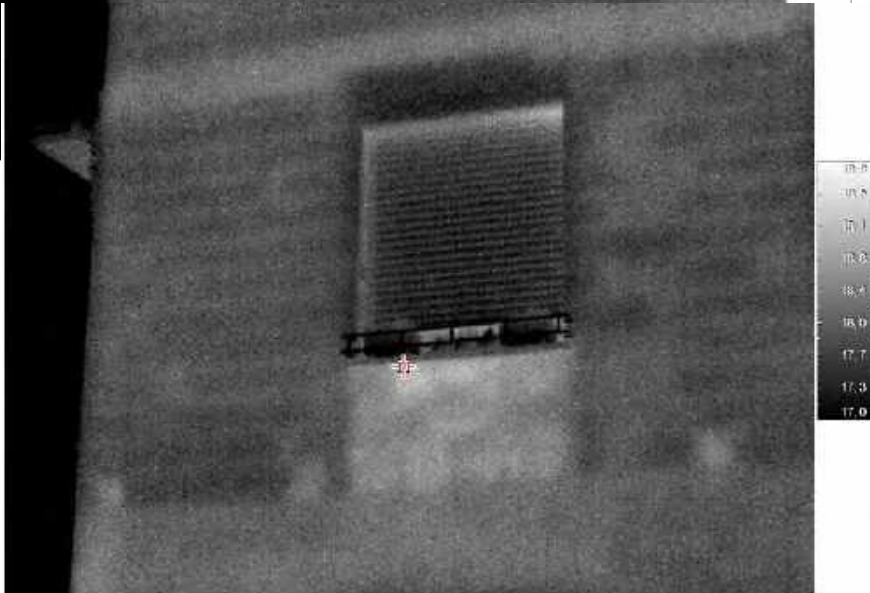
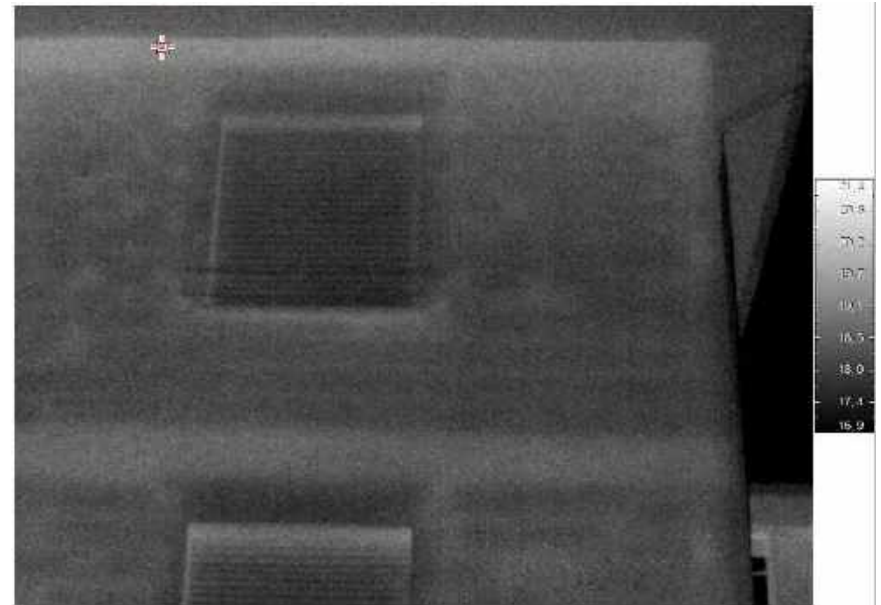
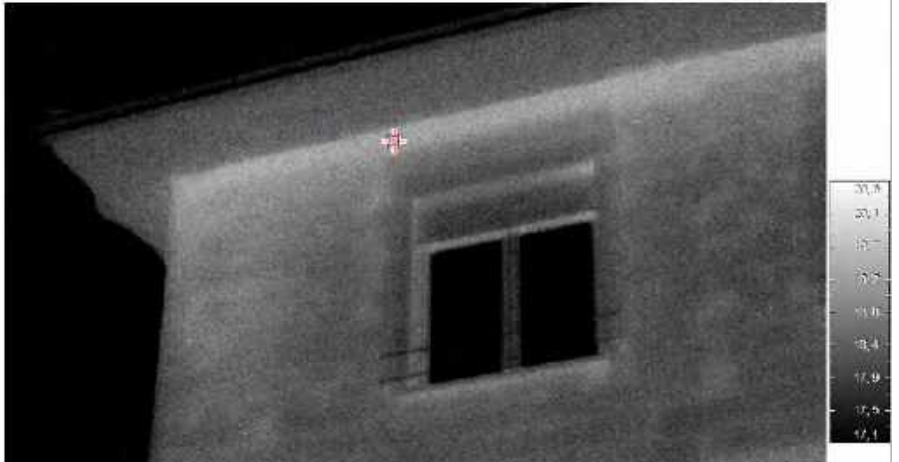




# East (details)

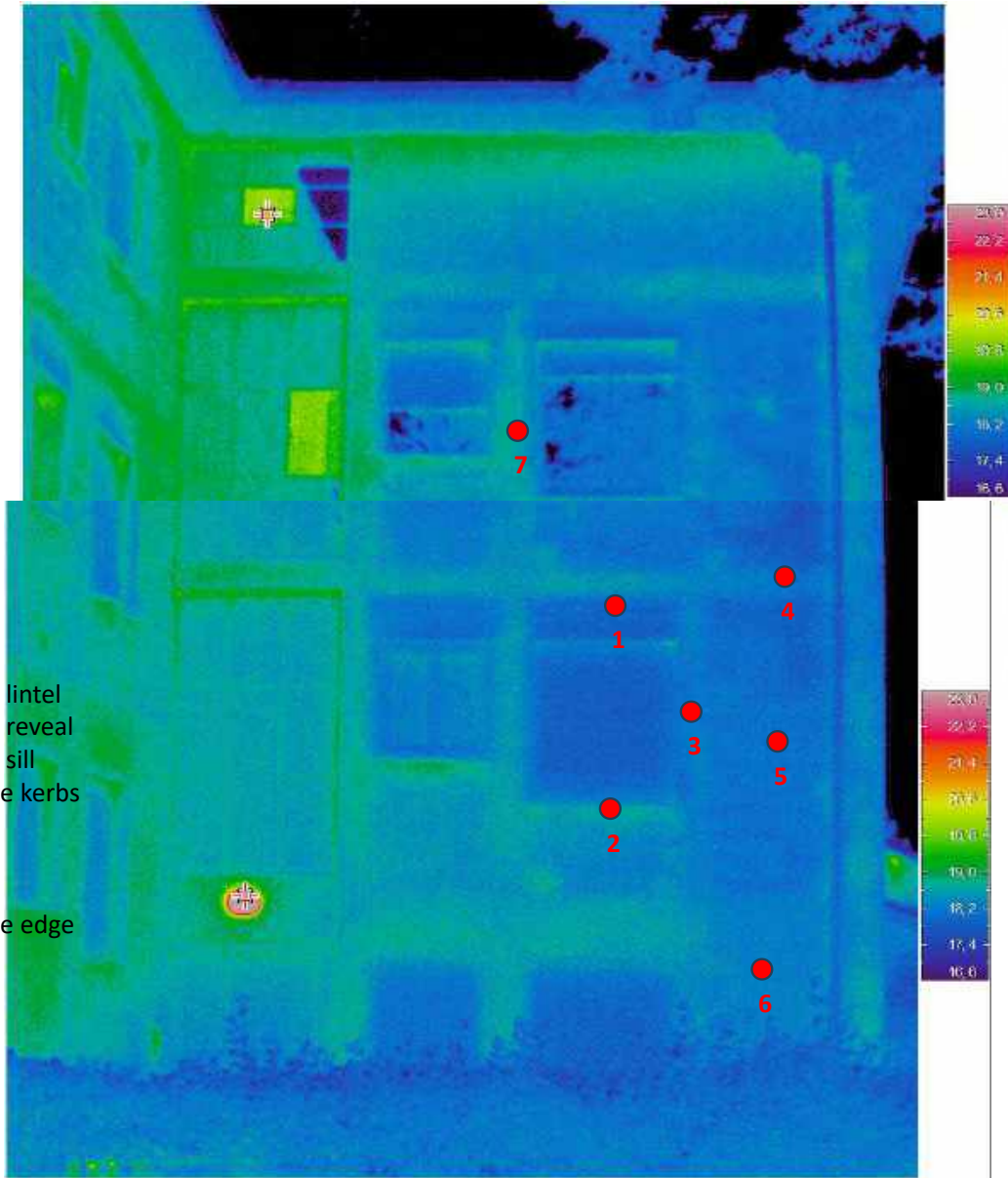


# East (details)

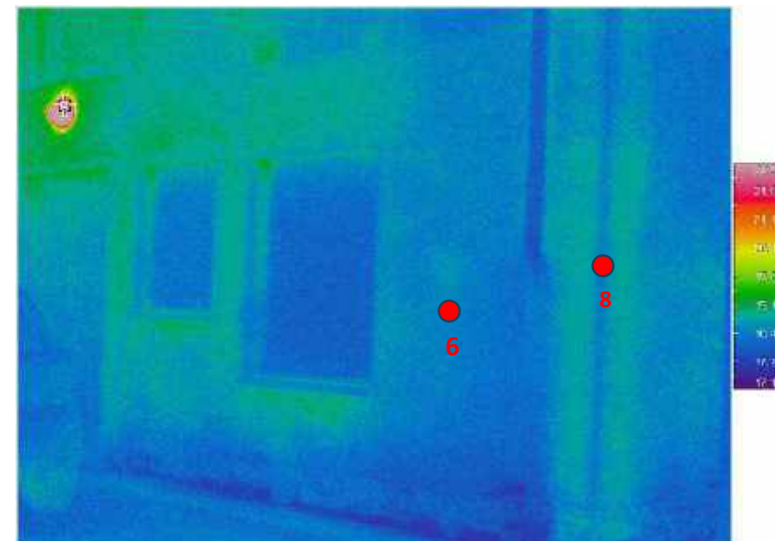




**East-North**

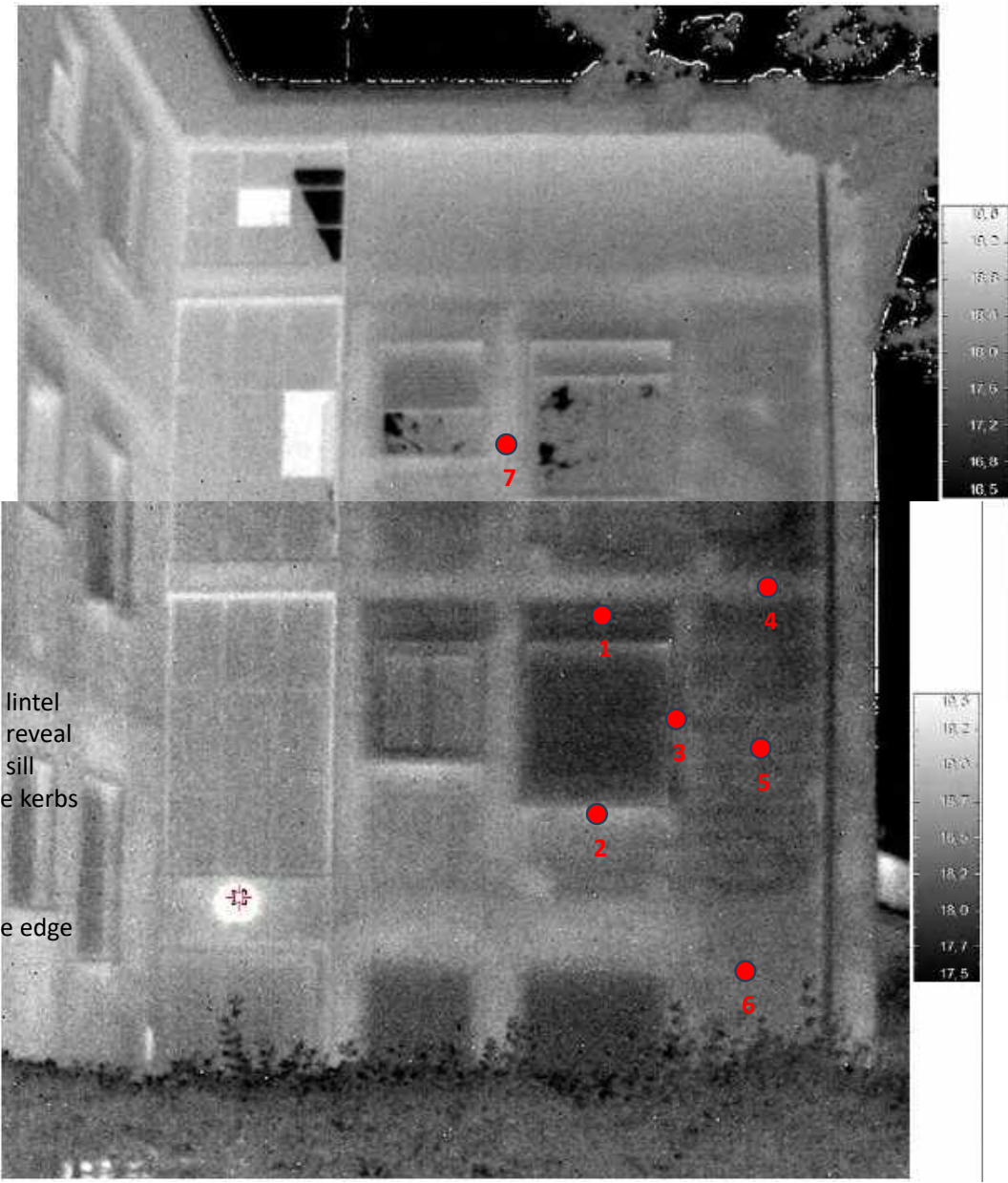


- 1. Thermal bridges of the window lintel
- 2. Thermal bridges of the window reveal
- 3. Thermal bridges of the window sill
- 4. Thermal bridges due to concrete kerbs
- 5. Brick block masonry
- 6. Natural stone masonry
- 7. Probable concrete pillar
- 8. Thermal bridges due to concrete edge

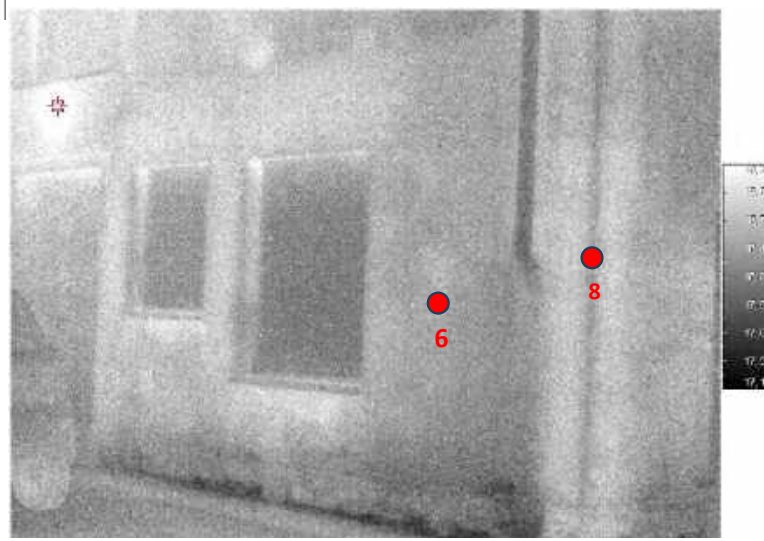




**East-North**



- 1. Thermal bridges of the window lintel
- 2. Thermal bridges of the window reveal
- 3. Thermal bridges of the window sill
- 4. Thermal bridges due to concrete kerbs
- 5. Brick block masonry
- 6. Natural stone masonry
- 7. Probable concrete pillar
- 8. Thermal bridges due to concrete edge



**SOUTH FACADE**



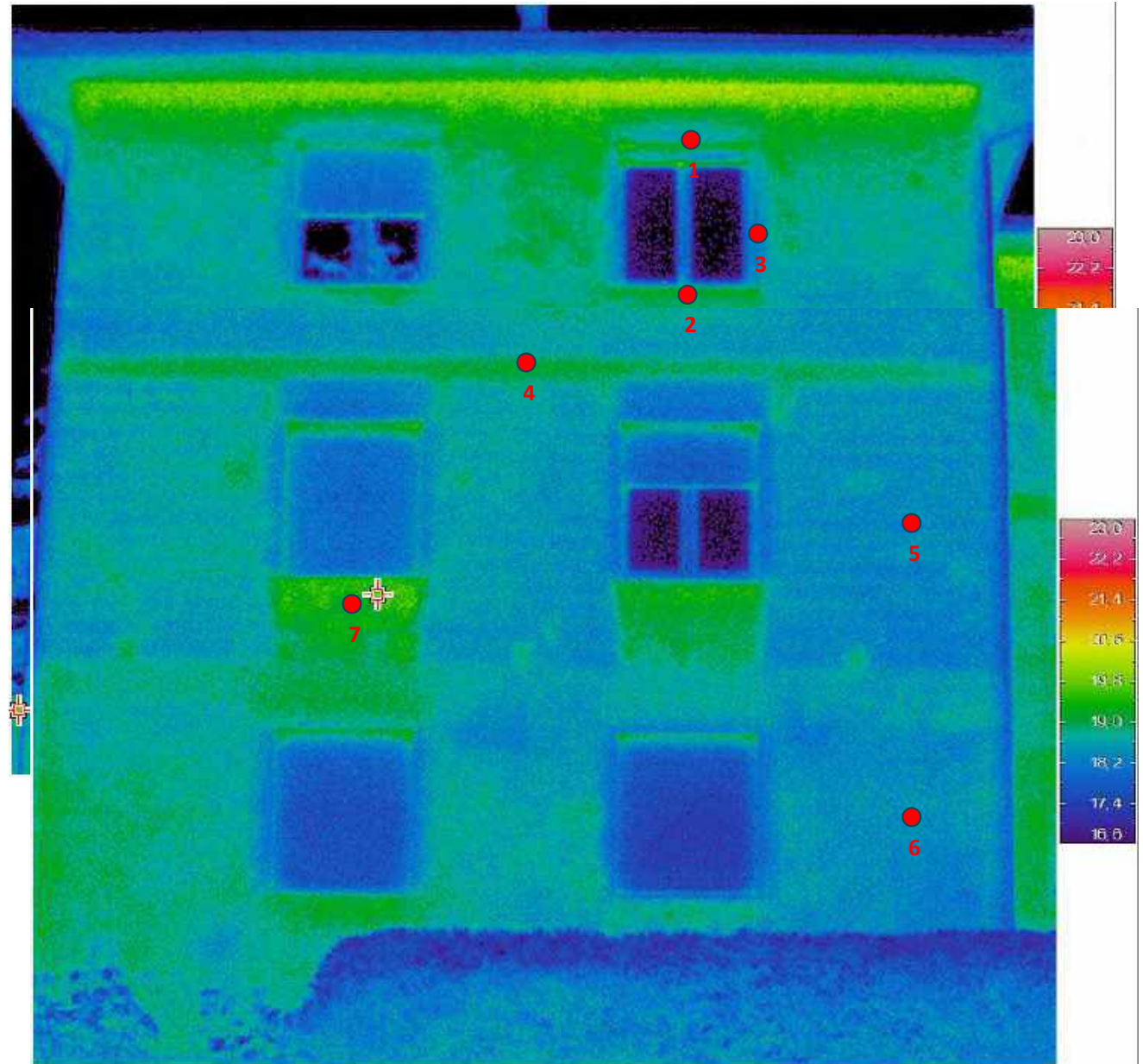
*South-West*

*South-East*





## South-West

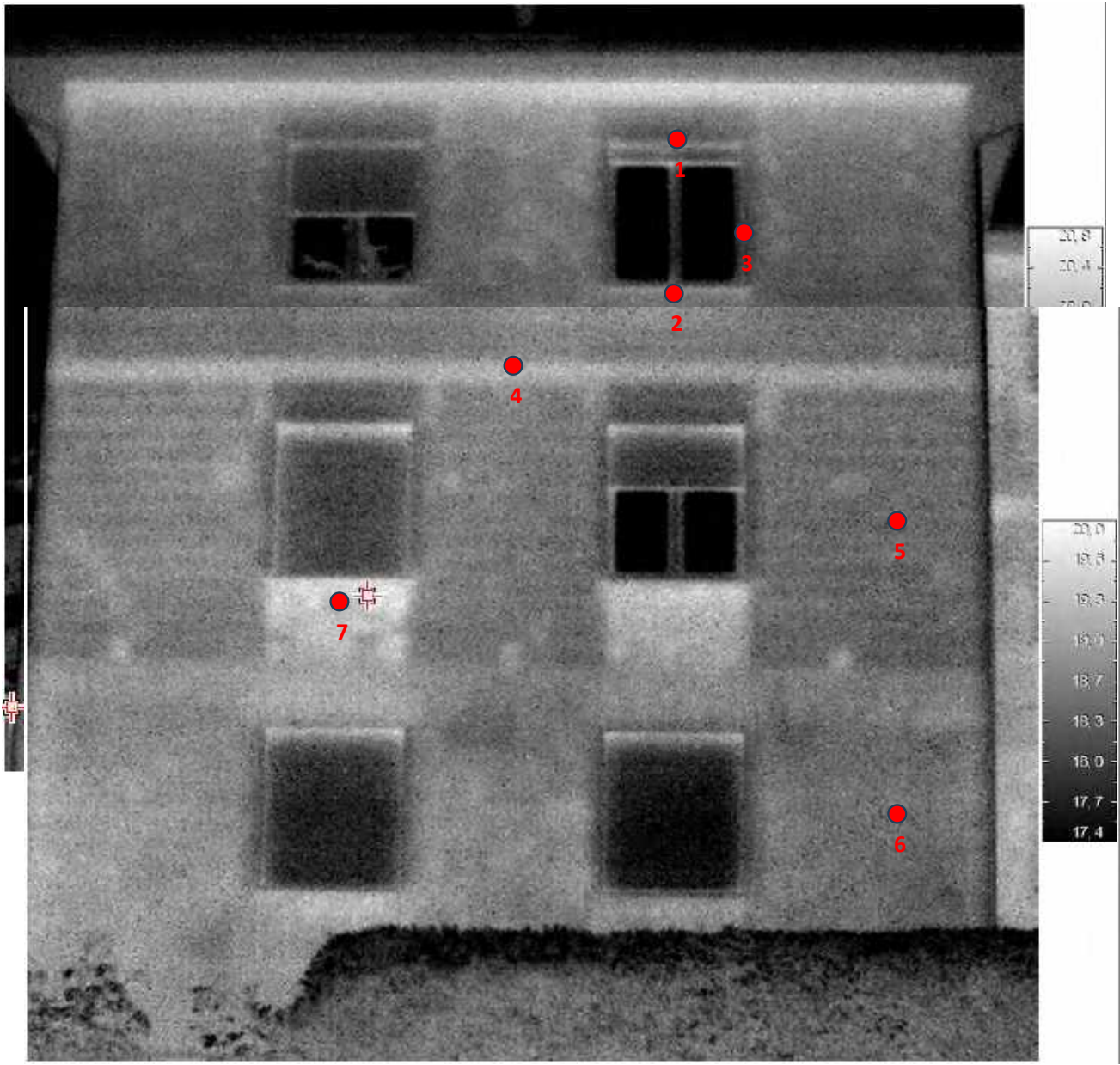


1. Thermal bridges of the window lintel
2. Thermal bridges of the window reveal
3. Thermal bridges of the window sill
4. Thermal bridges due to concrete kerbs
5. Brick block masonry
6. Natural stone masonry
7. Radiators

**South-West**

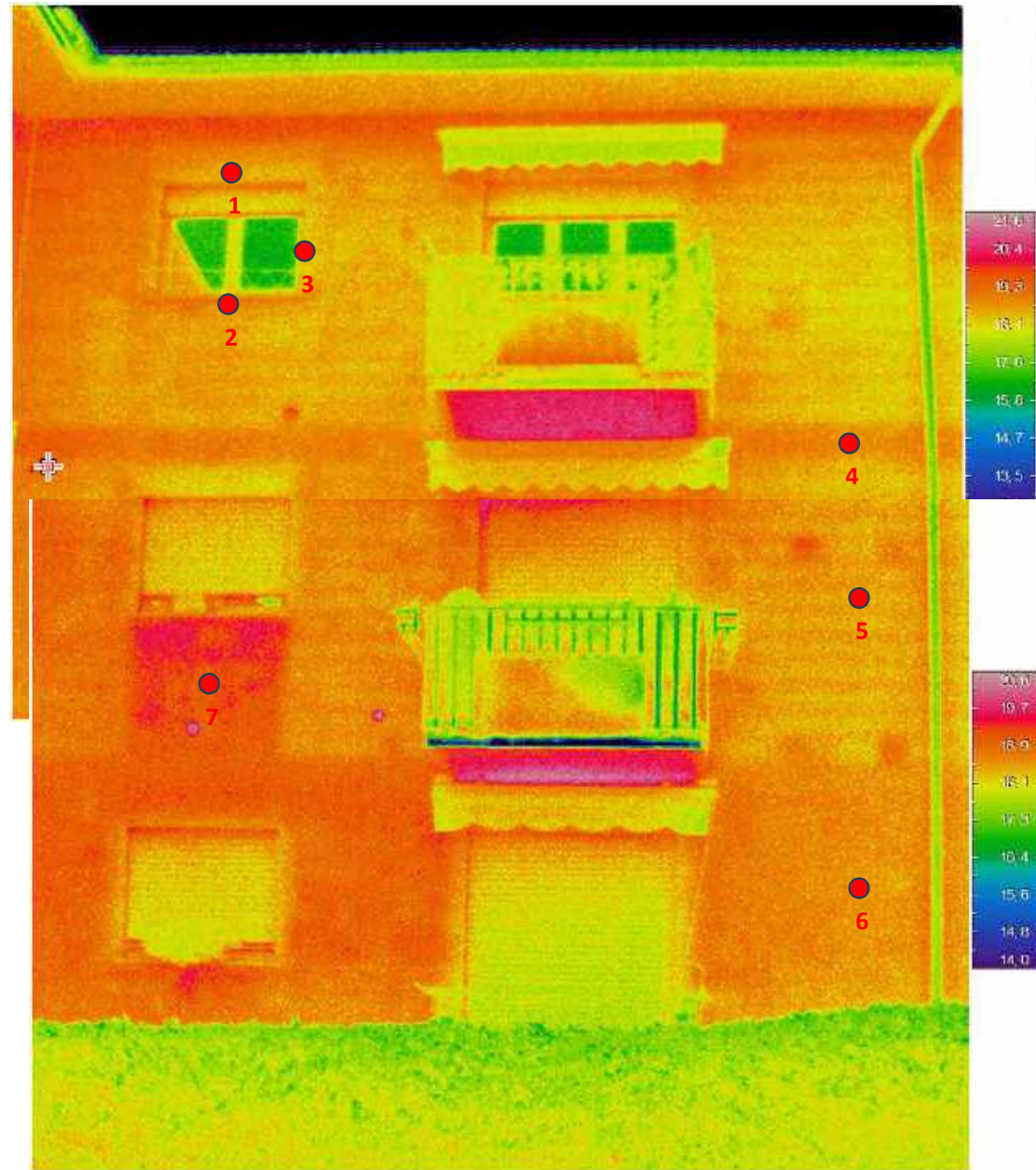


- 1. Thermal bridges of the window lintel
- 2. Thermal bridges of the window reveal
- 3. Thermal bridges of the window sill
- 4. Thermal bridges due to concrete kerbs
- 5. Brick block masonry
- 6. Natural stone masonry
- 7. Radiators





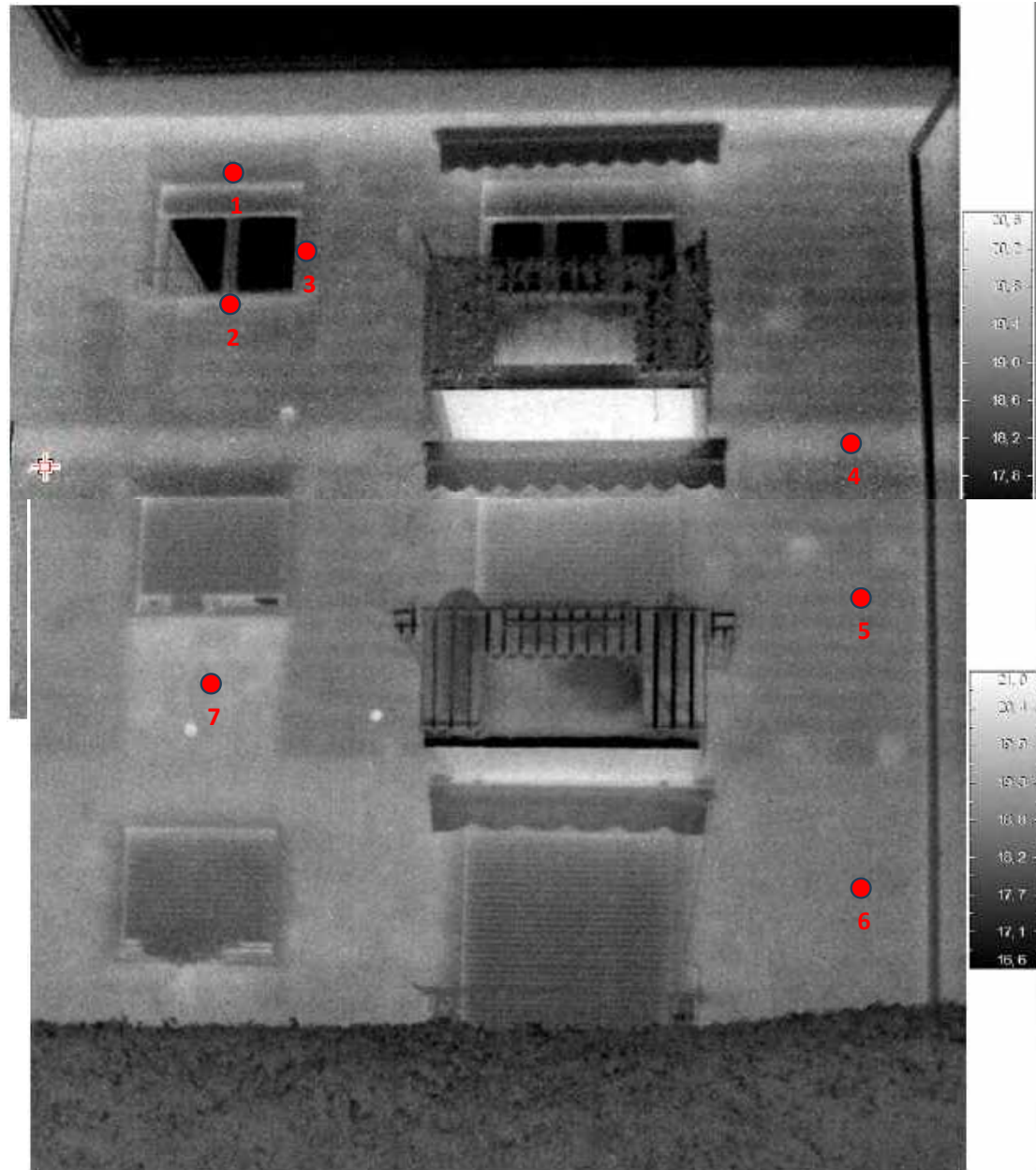
## South-East



1. Thermal bridges of the window lintel
2. Thermal bridges of the window reveal
3. Thermal bridges of the window sill
4. Thermal bridges due to concrete kerbs
5. Brick block masonry
6. Natural stone masonry
7. Radiators



## South-East



1. Thermal bridges of the window lintel
2. Thermal bridges of the window reveal
3. Thermal bridges of the window sill
4. Thermal bridges due to concrete kerbs
5. Brick block masonry
6. Natural stone masonry
7. Radiators

## WEST FACADE

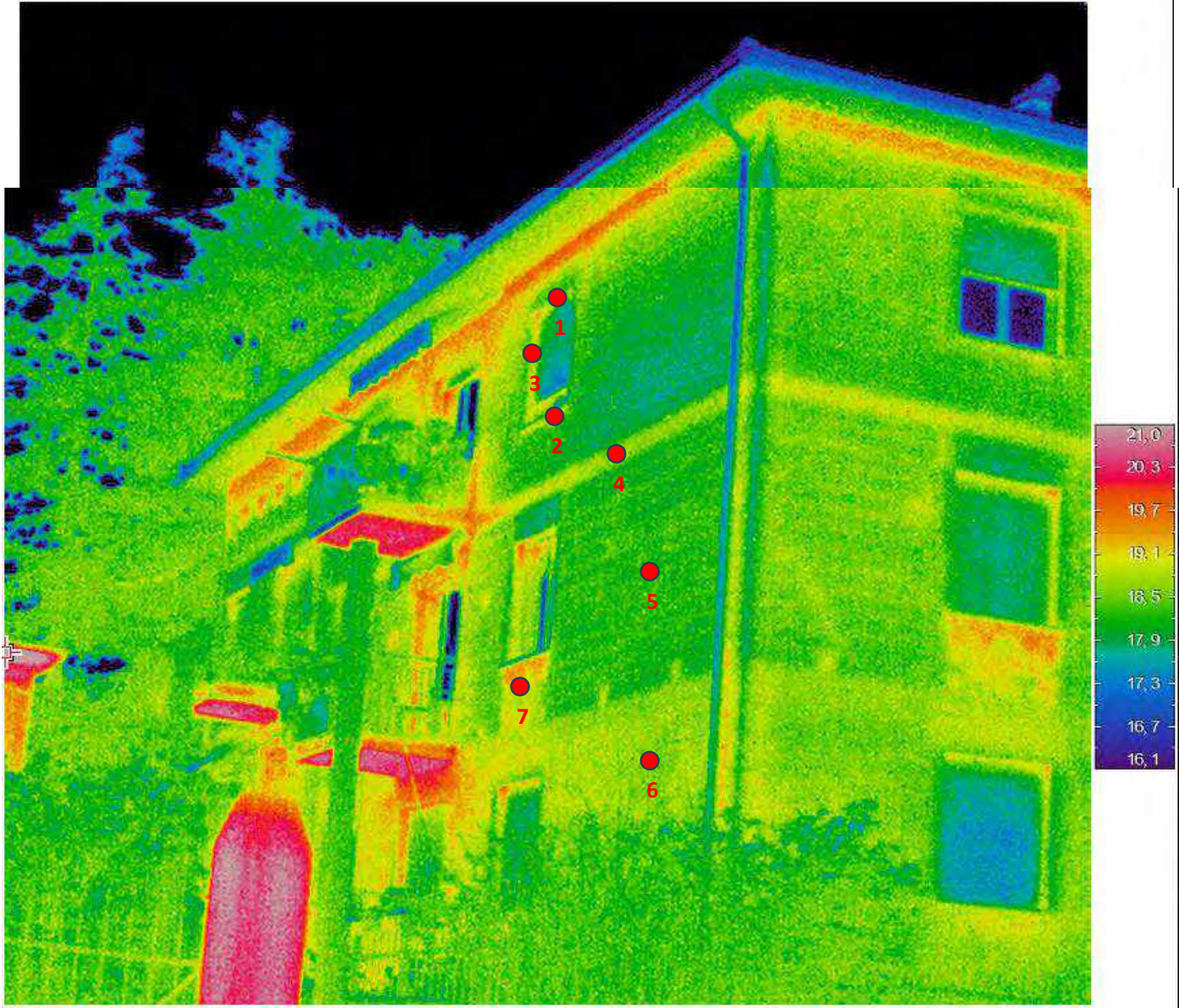




**West**



- 1. Thermal bridges of the window lintel
- 2. Thermal bridges of the window reveal
- 3. Thermal bridges of the window sill
- 4. Thermal bridges due to concrete kerbs
- 5. Brick block masonry
- 6. Natural stone masonry
- 7. Radiators





**West**



- 1. Thermal bridges of the window lintel
- 2. Thermal bridges of the window reveal
- 3. Thermal bridges of the window sill
- 4. Thermal bridges due to concrete kerbs
- 5. Brick block masonry
- 6. Natural stone masonry
- 7. Radiators





CLIMATE POSITIVE CIRCULAR COMMUNITIES

## **ANNEX**

### **9.3.13 Geometric survey**

**D4.5 DESIGN GUIDELINES OF CLIMATE POSITIVE CIRCULAR COMMUNITY IN  
TRENTO**

**WP4 SUSTAINABLE BUILDING (RE) DESIGN**





*Figure 1 – Top view of the case study, a 3-floor private apartment building located in via Pantè 2, Trento, Italy.*

The intervention on the existing building consists of the renovation of a private apartment building through a modular prefabricated system based on timber, developed as a retrofit kit to improve energy efficiency, indoor comfort and architecture aesthetics of existing buildings. The **production and installation of prefabricated panels require a detailed knowledge of the building geometry, to ensure they fit with existing walls.** To acquire **accurate geometric data in a reasonable time and at an affordable cost**, it is necessary to conduct an effective survey campaign, **using appropriate technologies for the scope and taking into account building features**, as size and context. In addition, it is necessary to **process acquired data with the aim of obtaining digital models to support designers, contractors and manufacturers.**

**Different acquisition and processing strategies have been tested on the case study**, to compare their effectiveness under environmental conditions and verify their replicability.

The case study is a 3-floor building, covering a 254 m<sup>2</sup> surface, surrounded by a private courtyard on all sides (**Figure 1**). External walls are straight, with homogeneous surfaces. Some balconies protrude from the south and west façades, while the north and east façades, used for the comparison, have windows.

The following technologies have been used for outdoor data acquisition:

1. A **total station** (Topcon GPT 1001) has been used for a traditional topographic survey to obtain **reference points, useful for processing and comparing other acquired data.** 100 points have been identified on the existing building surfaces, and their coordinates have been acquired from 4 stations (**Figure 2**).
2. **LiDAR (Light Detection and Ranging) scanning technology, incorporated into an iPad Pro.** 50 scans have been acquired using *Scaniverse*<sup>1</sup> free application from the ground level and from a lifting platform (**Figure 4**). Each scan represents a small portion of the existing building.
3. **3DEye system**<sup>2</sup>, composed of a **9 m telescopic pole**, a **mirrorless camera** (Sony Ilce 6000), a **gimbal device to control camera orientation and stabilisation**, and a **tablet to control framing and shooting from the ground level.** A set of 802 photos has been acquired from the ground level. These represent the building external walls from a distance of about 2 m and different orientations (**Figure 3**).
4. **Reflex camera** (Canon Eos 600D). A set of 142 pictures has been acquired from the ground level and from the lifting platform. Photos represent as entirely as possible building facades from different perspectives (**Figure 6**).
5. **SLAM (Simultaneous Localization And Mapping) scanning technology** through GeoSLAM Zeb Horizon<sup>3</sup>, a portable and dynamic device. A single scan has been acquired from the ground level and from the lifting platform (**Figure 5**).



**Figure 2** – On the left, the total station in use. On the right, blue points represent the 4 stations, green ones represent points acquired during the topographic survey.





Figure 4 – On the left, the iPad in use. On the right, some scans acquired with Scaniverse application.

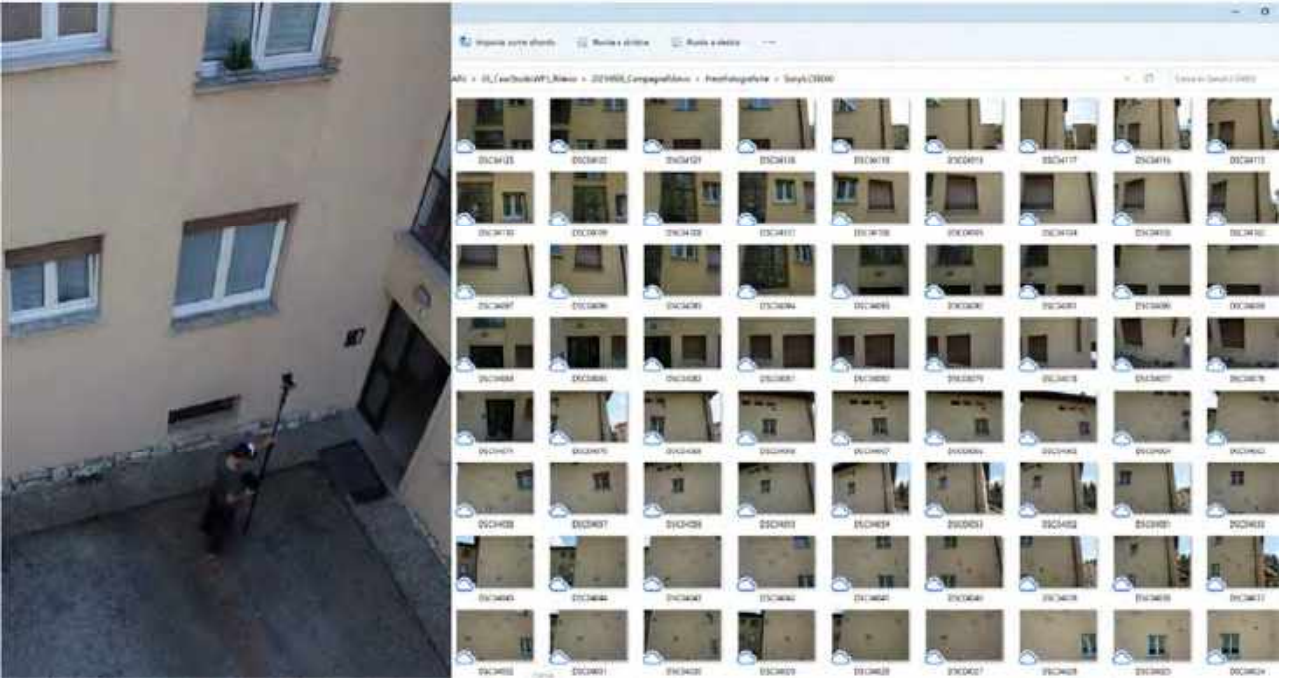
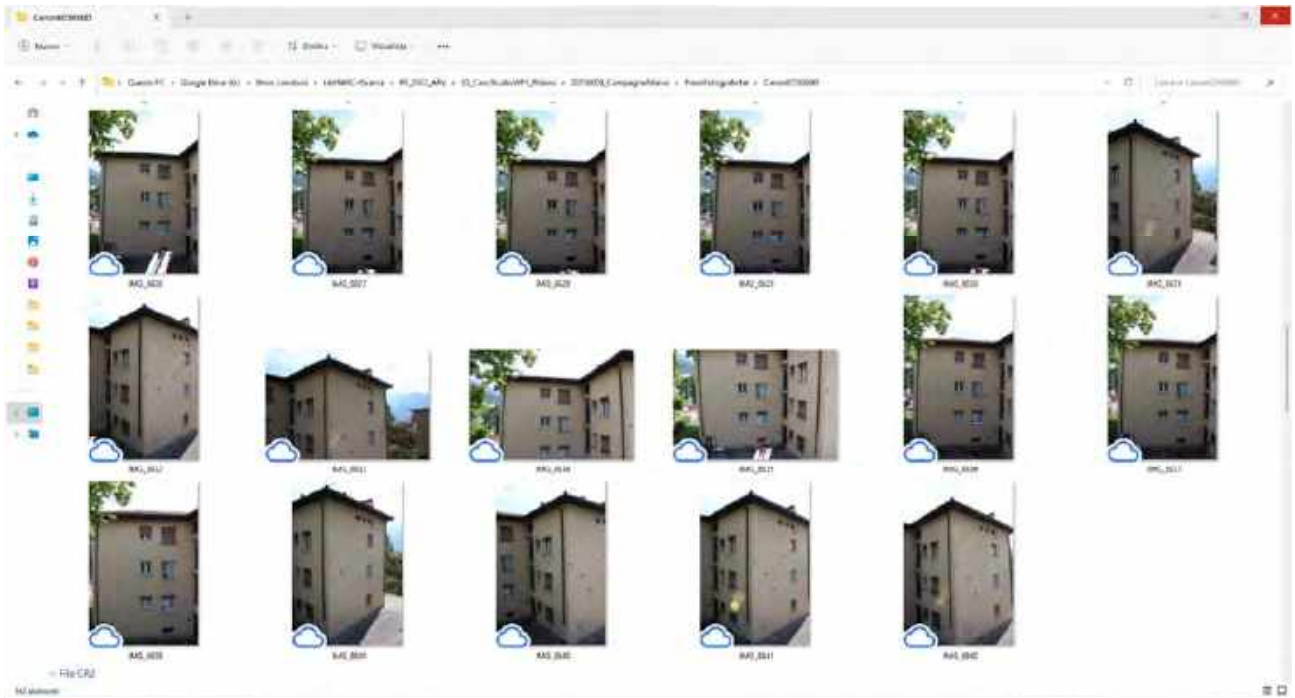


Figure 3 – On the left, the 3DEye system in use. On the right, set of photos acquired through 3DEye system.



*Figure 6 – Set of photos acquired through reflex camera from the ground level and from the lifting platform.*



*Figure 5 – GeoSLAM Zeb Horizon device in use from the ground level.*



**Acquired raw data have been used separately or combined in the processing phase** to generate three-dimensional representations of the building, as explained in the following paragraph.

Different **point clouds** and **images obtained** have been **aligned using the coordinates of the topographic points as references**.

Measured **accuracy** of generated clouds is **relative to the topographic survey**. Different clouds have been compared measuring their distance from topographic points through the *Cloud-to-cloud* function of *Cloud Compare*<sup>4</sup> free software. They have also been compared with a terrestrial laser scanner (TLS) cloud, previously acquired by the contractor.

#### A. Generation of a dense point cloud from iPad scans (Figure 7 )

- Selection of suitable scans for the construction of the overall cloud (manual).
- Scans export from *Scaniverse* app in point clouds .las format (manual).
- Point clouds (.las) import in *Cloud Compare* (manual).
- Topographic points (.dxf) import in *Cloud Compare* (manual).
- Alignment of each cloud to the topographic points through at least 3 reference points (semi-automatic).
- Clouds cleaning and union (manual).

#### Notes

- *Scaniverse* application allows objects of different sizes to be scanned. The **maximum distance is 5 m for large objects** (buildings) and **2,5 m for small objects** (window, details, etc.).
- **Scanning time depends** on the building **height** (necessity of a lifting platform for more than 5 m) and the **space available around** the building (lifting platform handling).
- **Overlapping of scans is necessary** to subsequently align several point clouds. At least 3 common reference points are required to align two clouds.
- **Density and quality** of the clouds depend on the scanning distance.
- **Reliability of clouds depends** on the presence of **reference points on the surfaces**.
- **Quality and reliability** of clouds **depend on lighting conditions**.
- Cloud alignment is a semi-automatic procedure that takes about 20 minutes per cloud. The **processing time depends on the number of scans**.

#### Limits

- As the **distance from the object increases**, the **density and quality of acquired clouds decrease**. Buildings taller than 5 m can only be scanned entirely using a lifting platform.



Figure 7 – Point cloud generated from iPad (*Scaniverse*) acquisitions.



- **Acquisition time** considerably **increases** if the **building is taller than 5 m** and **surrounded by narrow spaces** (necessity of a lifting platform).
- **Reliability of clouds** is **not ensured** in the case of **large regular and homogeneous surfaces**, such as plaster-finished façades (lack of reference points).
- **Quality and reliability** of clouds obtained are **not ensured** in case of **variable light, bright light and backlighting**.
- **Reflecting objects**, such as metal and glass, are **not acquired properly**.

### Advantages

- **Low-cost** instrument.
- **Easy to handle** from the ground level and in narrow spaces, allows to **avoid some occlusions**.
- **Fast acquisition and processing** times.
- **Good reliability and quality of scans in optimal conditions** (light, surface, distance).

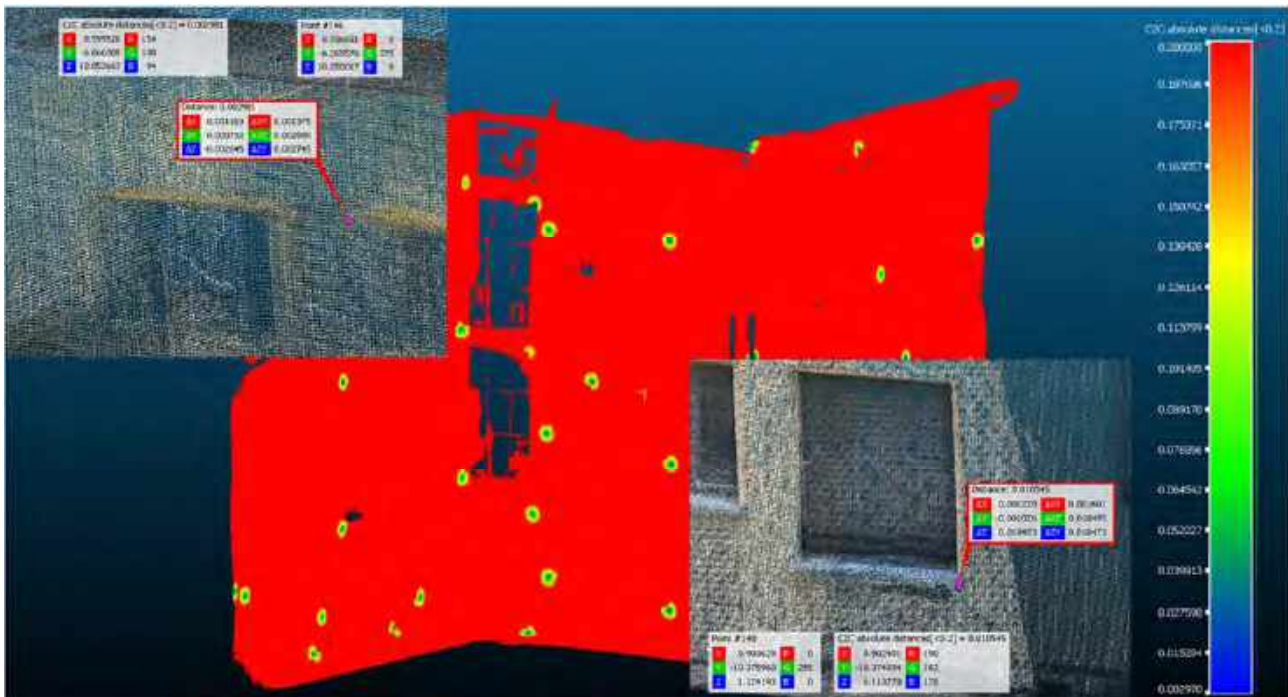
### Conclusions

The acquisition with the **LiDAR technology incorporated in iPad Pro** revealed limits and advantages.

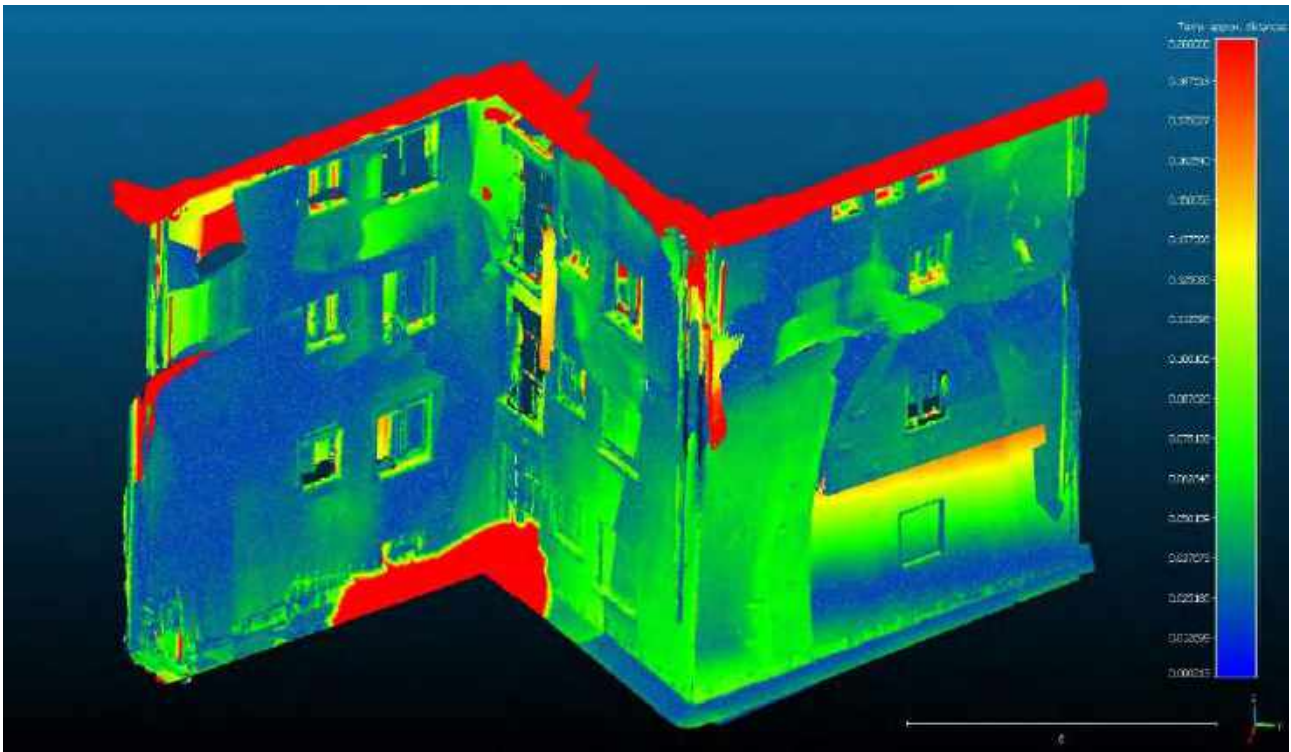
The resulting dense cloud of **6.063.099 points** fits well into the **topographic survey boundaries**, the **minimum distance** from reference points is about **3 mm**, the **maximum distance** is about **10 mm** (**Figure 8**). The acquisition of **large, homogeneous surfaces is not recommended**, especially if millimetre accuracy is required for detailed 3D reconstruction. In fact, in this case **lying planes are not always unique and perfectly straight**, as can be seen in the comparison with the TLS cloud (**Figure 9**).

This strategy can be useful for the **survey of small buildings** (not taller than 5 m), for a **detailed reconstruction of the ground attachment geometry**, and for the **integration of data acquired with other technologies**, e.g. to complete clouds acquired with TLS in case of occlusion. **Acquisition and processing times are fast** considering the overmentioned cases.

The **costs** to implement this strategy are **very low**, as they only involve the purchase of the LiDAR-equipped device.



**Figure 8** – Cloud point generated from iPad scans compared with topographic points. Closest points are highlighted in blue.



**Figure 9** – Point cloud generated from iPad scans compared with TLS cloud. Closest points are highlighted in blue.

**B. Generation of a point cloud through 3D photogrammetry from 3DEye system and reflex camera photos using 3DF Zephyr<sup>5</sup> software (Figure 10)**

- Selection of suitable photos for photogrammetric reconstruction (manual).
- Import selected photos into 3DF Zephyr software and identification of reference points on different photos, possibly coinciding with topographic points (manual).
- 3D reconstruction of the position of imported photos and scattered cloud processing (automatic).
- Cloud cleaning (manual or semi-automatic).
- Point coordinates insertion from topographic survey (semi-automatic).
- Correction of photo position and dense cloud processing (automatic).

**Notes**

- **Many pictures** acquired from different perspectives provide a **better three-dimensional reconstruction** of the object. **Context photos** acquired through reflex camera make it possible to locate a large number of reference points in three dimensions. **Detailed photos** acquired through the 3DEye system allow for greater definition in the reconstruction. The combination of both sets of photos offers the best results in terms of cloud density and accuracy.
- **Acquisition time depends** on the building **height** (necessity of a lifting platform) and the **space available around** the building (lifting platform handling).
- **Quality** of clouds obtained with photogrammetry **depends on the presence of reference points on the surfaces**.
- **Quality and reliability** of clouds obtained with photogrammetry **depend on lighting conditions**.
- **Overlapping of photos** and identification of at least **3 reference points for each photo** are necessary for the software to correctly reconstruct the position of the cameras.
- Individuating reference points is a manual procedure, **processing time depends on the number of photos**.

## Limits

- As the **distance** from the object **increases**, the **resolution of photos** and **cloud density decrease**. Buildings taller than the telescopic stick (9 m) can be photographed entirely using a lifting platform.
- **Acquisition time** considerably **increases if the building is taller than 9 m and surrounded by narrow spaces** (necessity of a lifting platform).
- **Quality** of clouds obtained through photogrammetry is **not ensured** in the case of **large regular and homogeneous surfaces**, such as plaster-finished façade (lack of reference points).
- **Quality and reliability** of clouds obtained through photogrammetry are **not ensured** in case of **variable light, bright light and backlighting**.
- **Slow processing** times for dense clouds.
- **Reflecting objects**, such as metal and glass, **are not processed properly**.

## Advantages

- **Low-cost** instrument.
- **Easy to handle** from the ground level and in narrow spaces, allows to **avoid some occlusions**.
- **Fast acquisition** times.
- **Good reliability and of clouds generated from photos acquired in optimal conditions** (light, surface, distance)

## Conclusions

The acquisition through a photographic set and the subsequent reconstruction of a point cloud through photogrammetry revealed limits and advantages.

The cloud of **1.835.233 points fits into the topographic survey boundaries**, but is **not very accurate and is not dense homogeneously**. The minimum distance from reference points is **8 mm**, the maximum distance is **90 mm (Figure 12)**.

**The acquisition of large, homogeneous surfaces is not recommended**, especially if millimetre accuracy is required for detailed 3D reconstruction. In fact, to obtain high resolution pictures cameras have to be close to the object, and in this case photogrammetry software does not correctly recognize photo position, due to lack of reference points. In addition, cloud density and resolution depend on the number of photos used for the photogrammetric reconstruction, but processing time increases with the number of photos, therefore this strategy is **not recommended to obtain clouds useful for detailed 3D reconstruction of the whole building in a short time**.

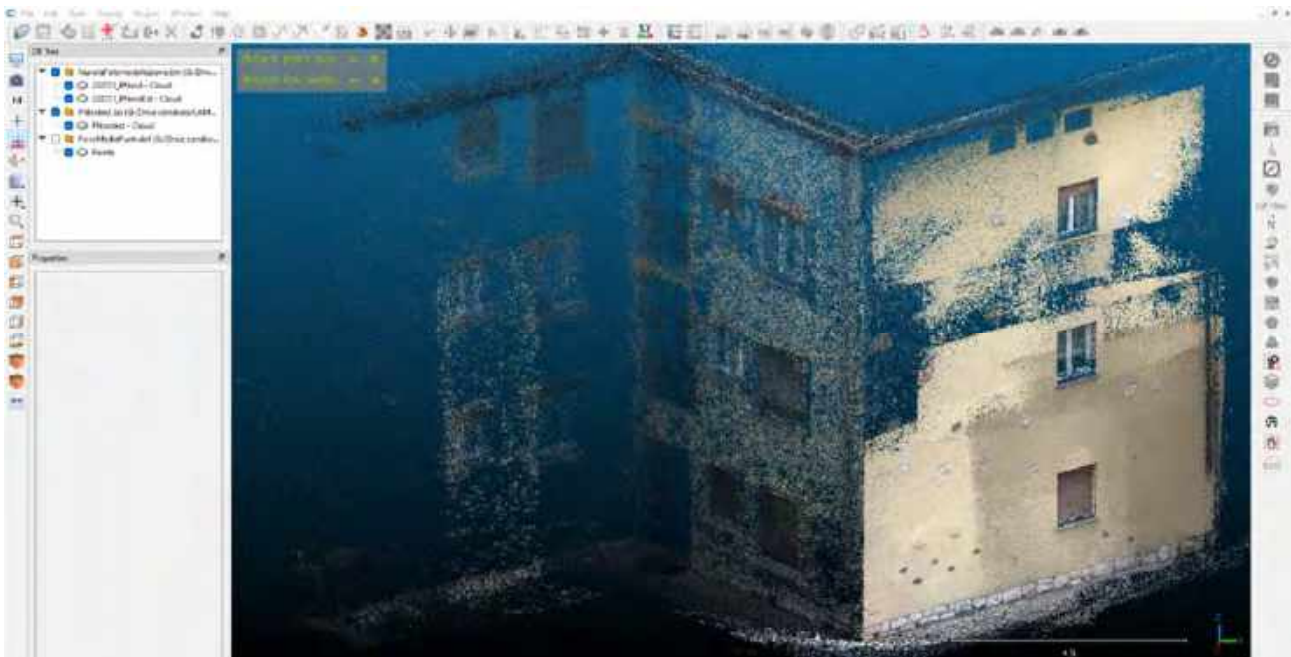
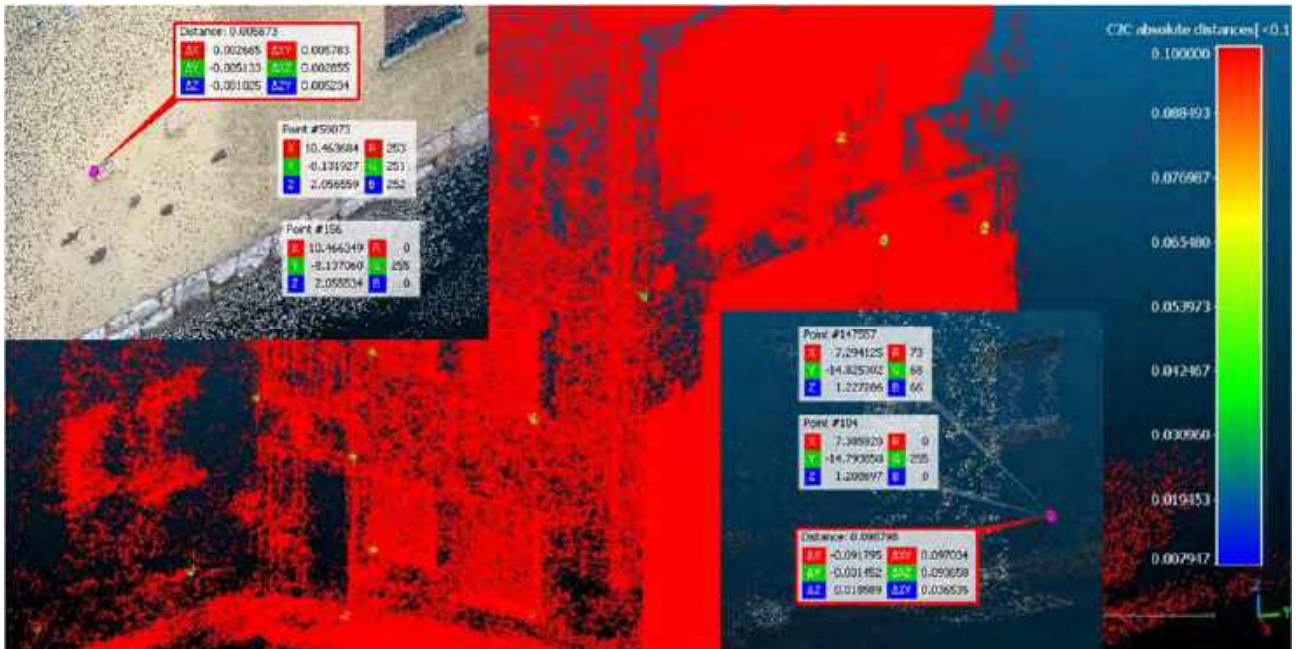


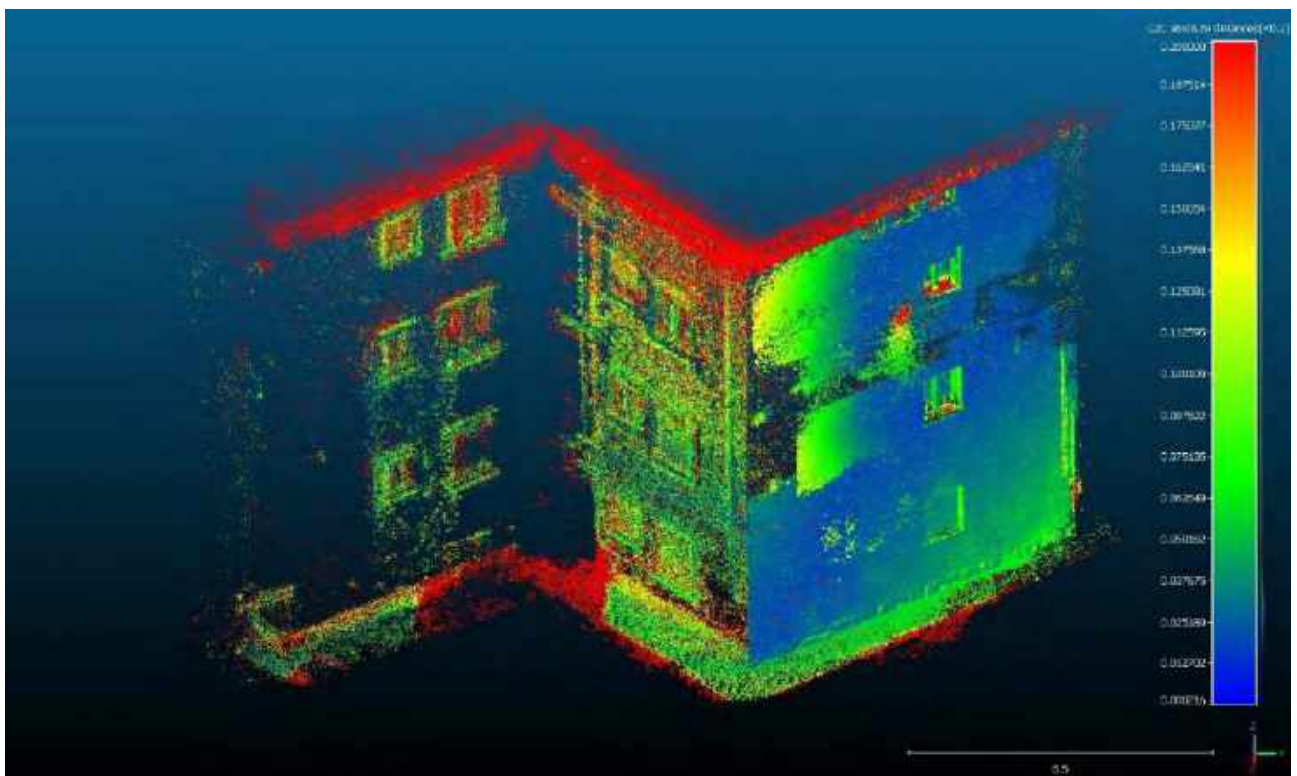
Figure 10 – Point cloud generated through photogrammetry (3DF Zephyr).



This strategy can be useful for the **survey of small buildings** (not taller than 9 m), and for the **integration of data acquired with other technologies**, e.g. to complete clouds acquired with TLS in case of occlusion. **Acquisition times are fast** considering the overmentioned cases. The **costs** to implement this strategy are **not very high**. They involve the purchase of the **equipment** and the **software** necessary to process data.



**Figure 12** – Point cloud generated with photogrammetry compared with topographic points. Closest points are highlighted in blue.



**Figure 11** – Point cloud generated with photogrammetry compared with TLS cloud. Closest points are highlighted in blue.

### C. Generation of a dense point cloud from GeoSLAM Zeb Horizon scan (Figure 13)

- Point cloud export from *GeoSLAM* software in .las format (manual).
- Point cloud (.las) import in *Cloud Compare* (manual).
- Topographic points (.dxf) import in *Cloud Compare* (manual).
- Alignment of GeoSLAM point cloud to the topographic points through at least 3 reference points (semi-automatic).
- Cloud cleaning (manual or semi-automatic).

#### Notes

- Scan is dynamic and geo-referenced, it can acquire points up to 100 m distance.
- **Acquisition time depends** on the building **height** (possibility of using a lifting platform) and the **space available around** the building (lifting platform handling).
- **Quality and reliability** of clouds **depend on distance**.
- **Quality and reliability** of clouds **do not depend on lighting conditions**.

#### Limits

- As the **distance** from the object **increases, the reliability of acquired clouds decreases**.
- **Acquisition time** considerably **increases if the building is tall** and **surrounded by narrow spaces** (use of a lifting platform).
- **Default scans** can be exported in **grey scale**, a specific licence is needed for RGB data.

#### Advantages

- **Easy to handle** from the ground level and in narrow spaces, allows to **avoid some occlusions**.
- **Fast acquisition and processing** times.
- **Quality and reliability of clouds** are ensured in normal outdoor environmental conditions.

#### Conclusions

The acquisition through SLAM device revealed limits and advantages. The dense cloud of **45.492.604 points fits well into the topographic survey boundaries**, the minimum distance from reference points is **2 mm**, the **maximum** distance is about **30 mm (Figure 15)**. The comparison with TLS cloud (**Figure 14**) shows that **reliability decrease with distance**.

The **acquisition of large, homogeneous surfaces is possible**, although it is recommended to record reference objects in three dimensions.

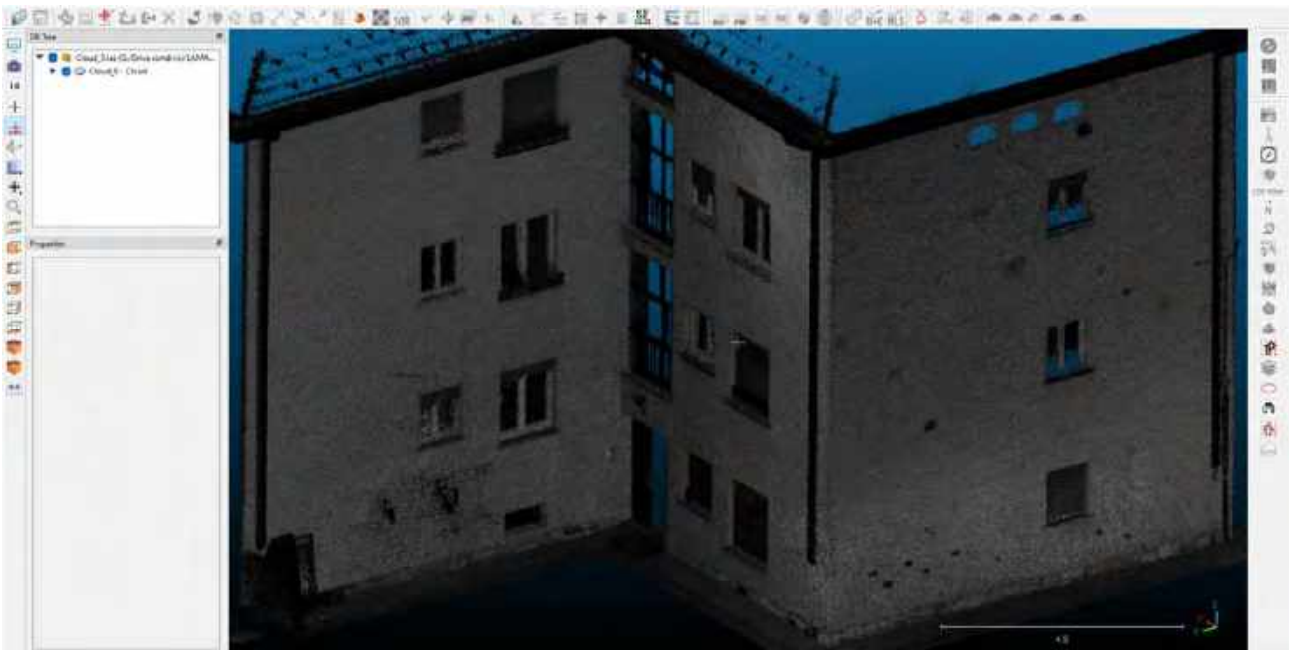
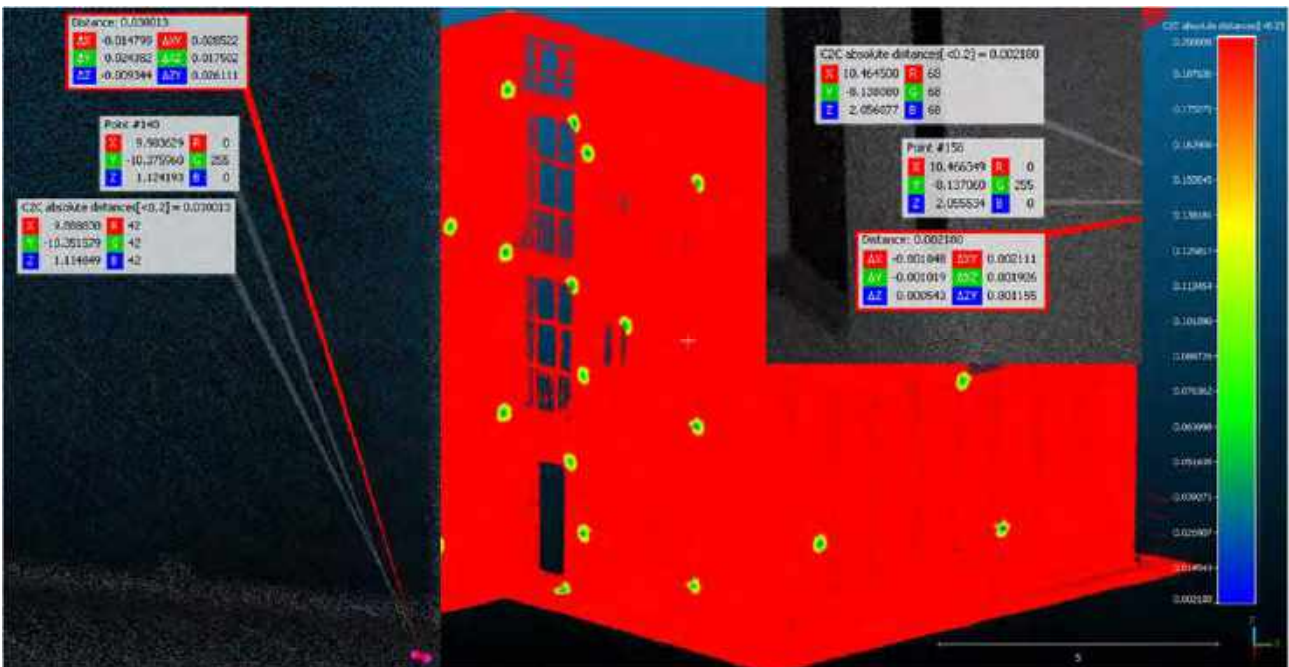


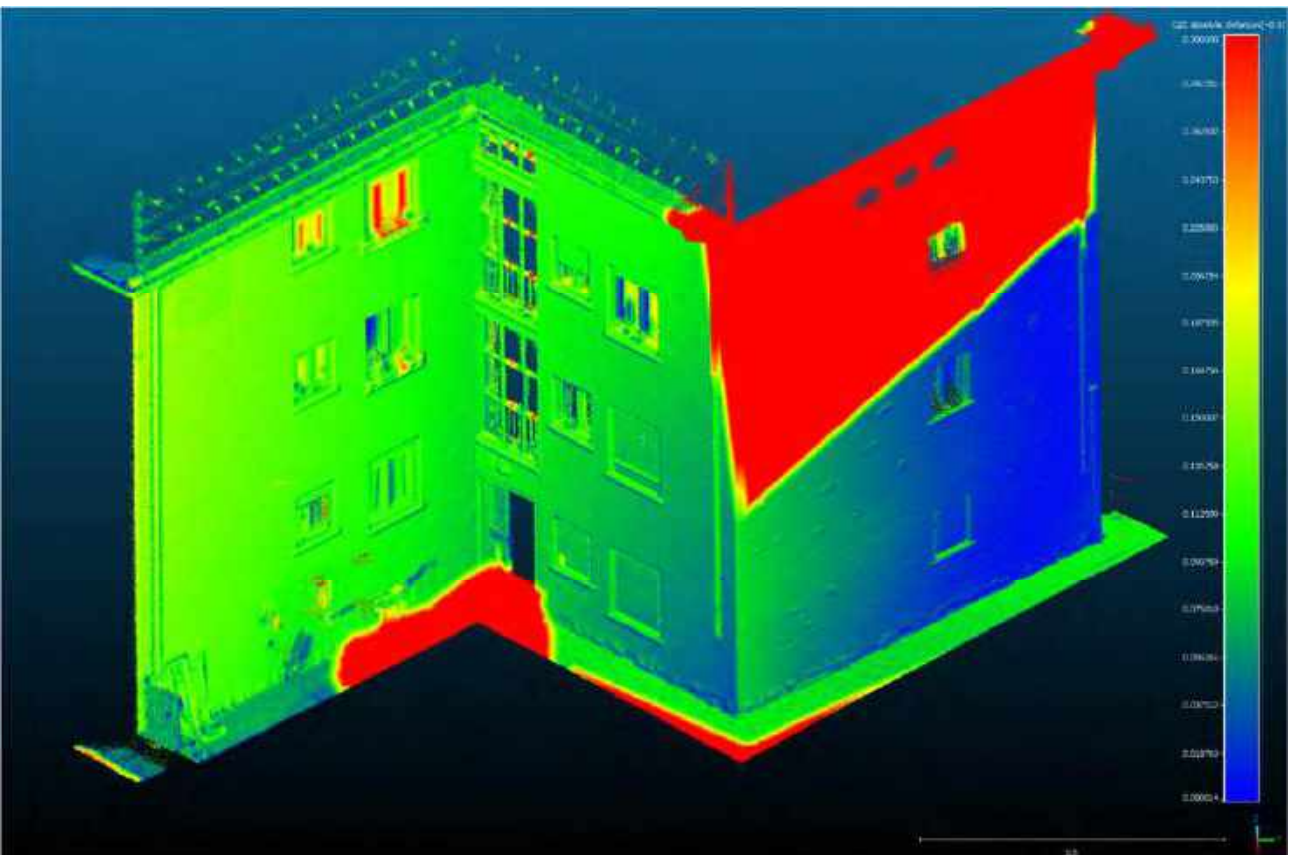
Figure 13 – Point cloud generated from GeoSLAM Zeb Horizon acquisition.



This strategy is **suitable for obtaining clouds for detailed 3D reconstruction of small and medium buildings in short times.**  
 The **costs** to implement this strategy are **high** if they involve the **purchase of the equipment** and the **software** necessary to process data.



*Figure 15 – Point cloud acquired with GeoSLAM Zeb Horizon compared with topographic points. Closest points are highlighted in blue.*



*Figure 14 – Point cloud acquired with GeoSLAM Zeb Horizon compared with terrestrial laser scanner cloud. Closest points are highlighted in blue. Red points have been scanned from a distance of about 10-15 m.*

#### D. 3D reconstruction from 2D rectified pictures (Figure 16)

- Selection of photos suitable for rectification (manual).
- Import of a single photo into *RDF* free software for their rectification (manual).
- Identification of at least 4 reference points, coinciding with topographic reference points (manual).
- Reference points coordinates import (manual).
- Analytical straightening (automatic).
- Rectified photo import and positioning into *AutoCAD* software (manual).

##### Notes

- **One single photo per façade is sufficient**, as frontal and centred as possible, but it is possible to straighten and join two or more photos.
- **Quality** of rectified pictures depends on the distance from the object.
- **Quality** of rectified pictures depends on lighting conditions.
- Individuating reference points is a manual procedure, **processing time depends on the number of photos**.

##### Limits

- **Three-dimensional features and objects** as windows and pipes are **flattened in two dimensions**.
- **Occlusions** as trees, other buildings, cars and other objects are **difficult to avoid**.
- As the **distance** from the object **increases, the resolution of the rectified picture decreases**.
- **Quality of the rectified picture** is not guaranteed in bright light and backlighting.

##### Advantages

- **Low-cost** instrument.
- **Fast acquisition and processing** times.

##### Conclusions

The acquisition using a photographic set and the subsequent reconstruction of 3D surfaces from rectified 2D images revealed limits and advantages. Pictures **fit within the boundaries** of the topographic survey, the **maximum distance from reference points** is about **28 mm**. However, the façade surfaces are approximated as perfectly straight, neglecting any protrusion, deformation or inclination.

This strategy can be useful for a **fast and low-cost reconstruction of volumes**. The **loss of three-dimensional information regarding objects laying on the façade surfaces** requires an integration of measurement for a detailed 3D modelling.



Figure 16 – 3D reconstruction from 2D rectified photos.

**Table\_ Survey strategies comparison\_ Existing Building in Povo district<sup>a</sup>**

<b>STRATEGY</b>	<b>RAW DATA / OUTPUT</b>	<b>COST<sup>b</sup></b>	<b>ACQUISITION TIME/ PROCESSING TIME</b>	<b>ACCURACY<sup>c</sup></b>	<b>LIMITS</b>	<b>ADVANTAGES</b>
Point cloud from LiDAR scans (iPad Pro)	Multiple cloud / Dense cloud 6.063.099 pt	1.000 / 1.500 €	1 h (ground level) 2,5 h (lifting platform) / Manual processing (cloud alignment) - 20 min. for cloud	d= 3,0 mm D= 27,4 mm	Distance from the object No regular and homogeneous surfaces Light conditions	Easy to handle - avoid occlusions Fast acquisition and processing Low-cost
Point cloud from photogrammetry (3DEye system and reflex camera)	Multiple photos / Low-density cloud 1.835.233 pt	4.000 € + software licence	1 h (ground level) 2,5 h (lifting platform) / Manual processing (ref. points individuation) - time depending on the number of pictures and reference points	d= 5,8 mm D= 98,3 mm	Distance from the object No regular and homogeneous surfaces Light conditions Slow processing	Easy to handle - avoid occlusions Fast acquisition Low-cost
Point cloud from SLAM scan (GeoSLAM Zeb Horizon)	Single cloud / High-density cloud 45.492.604 pt	15.000 / 60.000 €	0.5 h (ground level + lifting platform) / Automatic processing	d= 2,1 mm D = 30,0 mm	Distance from the object High costs	Georeferenced scans Easy to handle - avoid occlusions Fast acquisition and processing
3D reconstruction from 2D pictures	2D image / 3D volume	1.000 / 4.000 €	20 min. from the ground level 40 min. using the lifting platform / Manual processing (ref. points individuation) - 30 min. for picture	d= 1,7 mm D = 29,9 mm	Loss of 3D information Occlusions Distance from the object Light conditions	Fast acquisition and processing Low-cost

- a. The north and east façades have been used as references for the comparison.
- b. Reported costs are relative at the time of writing. The values are indicative and are given for the purpose of comparing tested strategies.
- c. Accuracy of the clouds is relative to the topographic survey. "d" is the minimum distance between the topographic points and respective points in the different clouds, measured using the *Cloud-to-cloud* function of *Cloud Compare* software. "D" is the maximum distance between the topographic points and respective points in the different clouds.

---

<sup>1</sup><https://scaniverse.com/>

<sup>2</sup><https://geo3d.hr/photogrammetric-systems/microgeo/microgeo-3deye>

<sup>3</sup><https://www.microgeo.it/prodotto/zeb-horizon/>

<sup>4</sup><https://www.cloudcompare.org/main.html>

<sup>5</sup><https://www.3dflow.net/it/software-di-fotogrammetria-3df-zephyr/>

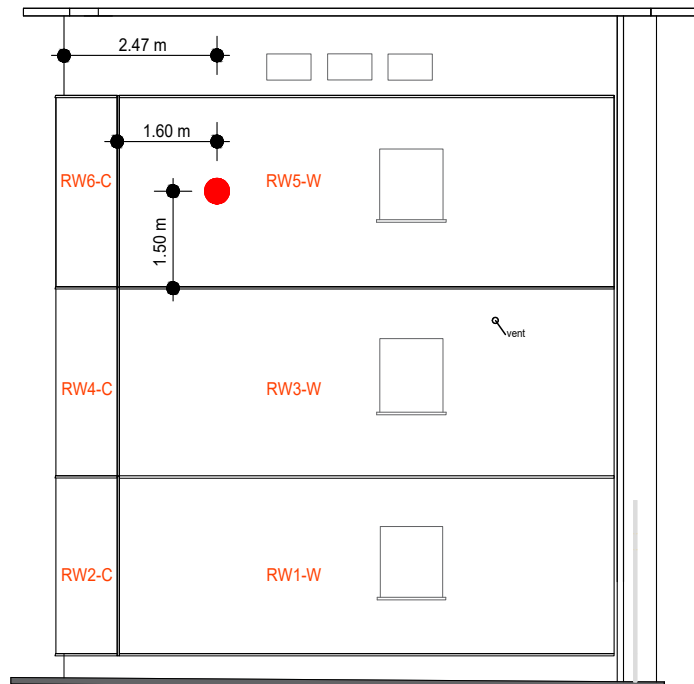
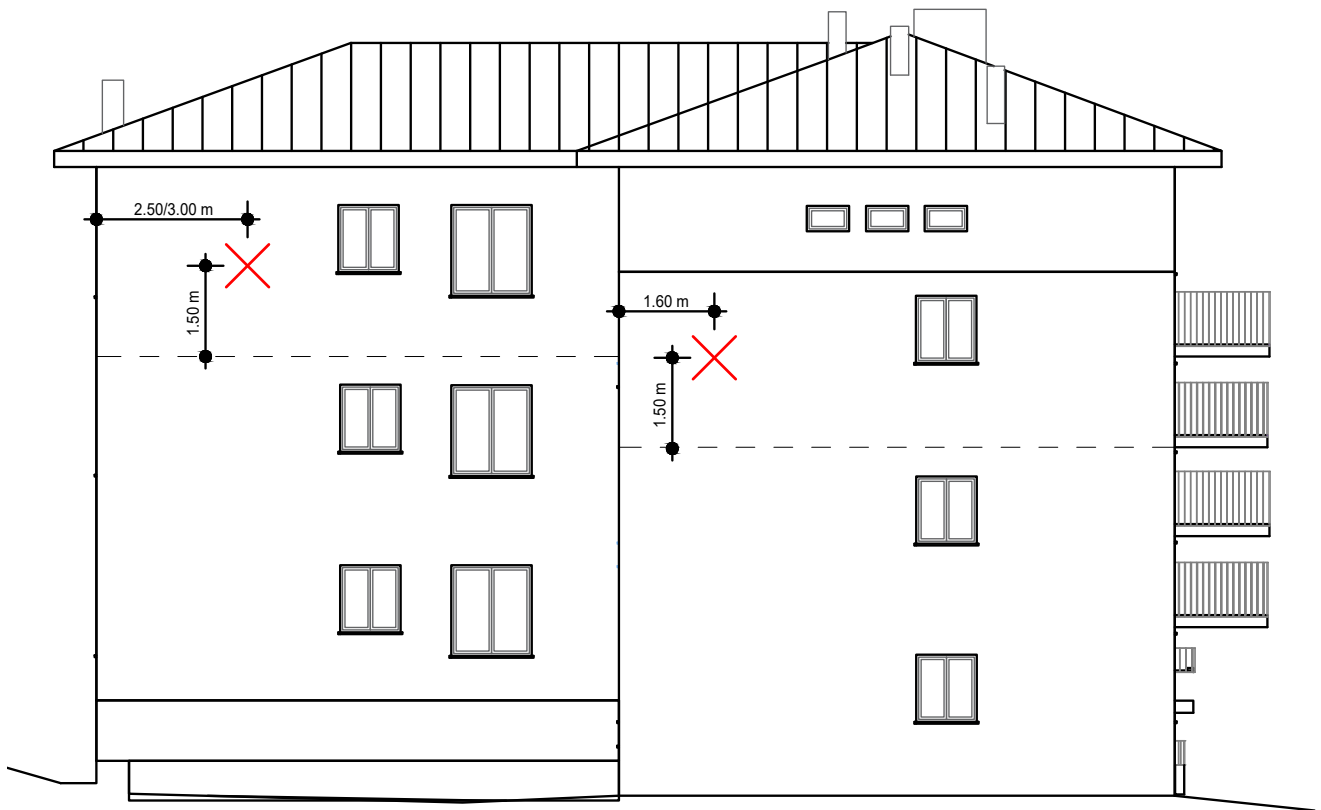


CLIMATE POSITIVE CIRCULAR COMMUNITIES

## **ANNEX**

### **9.3.14 Installation of sensors for envelope performance**

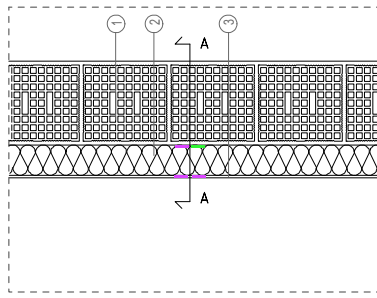




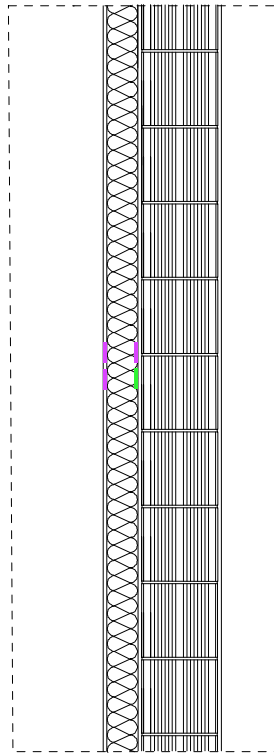
Placement of sensors - North/West elevation

- Surface temperature sensor
- Heat flow meter

HORIZONTAL SECTION



VERTICAL SECTION AA

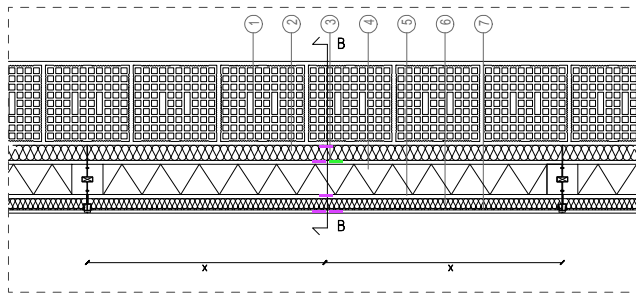


1. Existing wall
2. Thermal insulation board
3. Finishing layer

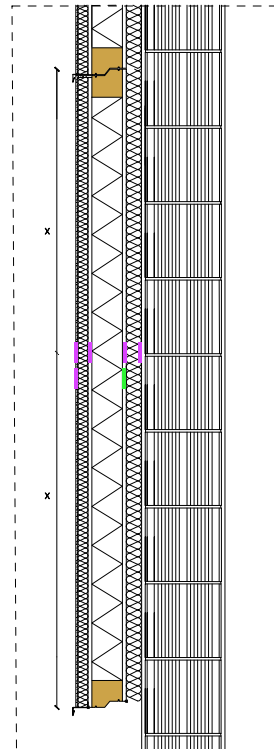
Existing wall + ETICS

- Surface temperature sensor
- Heat flow meter

HORIZONTAL SECTION



VERTICAL SECTION BB



1. Existing wall
2. Mineral wool insulation
3. OSB board
4. Load bearing wood structure + mineral wool insulation
5. Vapour-permeable DWD board
6. Thermal insulation board
7. Finishing layer

Existing wall + RW panel



Installation of sensors in ETICS for envelope monitoring





Installation of sensors in RW panel for envelope performance





Installation of sensors in RW panel for envelope performance





Installation of sensors in RW panel for envelope monitoring



CLIMATE POSITIVE CIRCULAR COMMUNITIES

## **ANNEX**

### **9.3.15 Construction site for the Refurbishment**





Construction site before the installation of the EPS insulation (ETICS) and RW panels





Installation of EPS insulation (ETICS)





Installation of RW panels





Installation of RW panels





Finishing work at the base and top of the RW panels







Installation of photovoltaic panels on the roof and storage equipments





Replacement of heating plants

## CONCLUSION AND FUTURE UPDATES

---

This document is the second version of the **DESIGN GUIDELINES OF CLIMATE POSITIVE CIRCULAR COMMUNITY (CPCC) in TRENTO**, with particular reference to the **WP4\_ SUSTAINABLE BUILDING (RE)DESIGN**.

Following feedback received in the first two years of the project and following the activities that will be carried out in the next year, **these guidelines will be supplemented and adjusted** as necessary.

In particular:

- the Existing Building will be monitored (energy performance, IEQ and envelope performance both of the traditional insulation system and of the Renew Wall one), the LCA and LCC will be updated, users' and designers' feedback will be collected with specific interviews;
- the Detailed Design of the New Building will be implemented as well as the construction and commissioning phases; the LCA analysis will be performed; the building will be monitored (energy performance, IEQ and envelope performance), designers' feedback will be collected with specific interviews.

**The document will be also revised based on the feedback given and lessons learned.** This continuous process will lead to a proven, validated, and consistent guidelines at the end of the project and one updated version of the current version of the document.

## REFERENCES

---

- [1] "EU Mission: Climate-Neutral and Smart Cities | European Commission."  
[https://ec.europa.eu/info/research-and-innovation/funding/funding-opportunities/funding-programmes-and-open-calls/horizon-europe/eu-missions-horizon-europe/climate-neutral-and-smart-cities\\_en](https://ec.europa.eu/info/research-and-innovation/funding/funding-opportunities/funding-programmes-and-open-calls/horizon-europe/eu-missions-horizon-europe/climate-neutral-and-smart-cities_en) (accessed Jul. 21, 2022).
- [2] "Delivering the European Green Deal | European Commission."  
[https://ec.europa.eu/info/strategy/priorities-2019-2024/european-green-deal/delivering-european-green-deal\\_en#documents](https://ec.europa.eu/info/strategy/priorities-2019-2024/european-green-deal/delivering-european-green-deal_en#documents) (accessed Jul. 21, 2022).
- [3] Amantino Amell, Cities key drivers of ecological transition (2020) in [www.sustainabilitycommunity.springernature.com/posts/title-here](http://www.sustainabilitycommunity.springernature.com/posts/title-here) (accessed Oct. 15, 2022).
- [4] Italian Institute for International Political Studies, The Role of Ecological Transition in Urban Development Projects, in <https://www.ispionline.it/en/pubblicazione/role-ecological-transition-urban-development-projects-29678> (accessed Jul. 21, 2022).
- [5] Demographic statistics. "Italian cities with more than 60,000 inhabitants".  
<https://www.tuttitalia.it/citta/popolazione/> (accessed Jul. 21, 2022).
- [6] "Trento-Fra tardo antico e medioevo. Gli interventi di Teoderico nel territorio di Tridentum."  
[http://alpiantiche.unitn.it/storia\\_dett.asp?id=53](http://alpiantiche.unitn.it/storia_dett.asp?id=53) (accessed Jul. 21, 2022).
- [7] TRIDENTUM - TRENTO (Trentino Alto Adige),  
<https://www.romanoimpero.com/2017/05/tridentum-trento-trentino-alto-adige.html?hl=en> (accessed Jul. 21, 2022).
- [8] Piedicastello. <https://it.wikipedia.org/wiki/Piedicastello> (accessed Jul. 21, 2022).
- [9] <https://www.piedicastello.tn.it/documenti/il-borgo/la-ex-scuola-elementare/> (accessed Jul. 21, 2022).
- [10] <https://www.piedicastello.tn.it/documenti/il-borgo/la-fabbrica-delle-brocche/> (accessed Jul. 21, 2022).
- [11] <https://www.comune.trento.it/Aree-tematiche/Ambiente-e-territorio/Parchi-e-giardini/Mappa-parchi-e-giardini/Elenco-parchi-e-giardini/Parco-naturale-del-Doss-Trento> (accessed Jul. 21, 2022).
- [12] Patrimonio del Trentino S.p.a.. Riqualificazione urbanistica Destra Adige – Piedicastello"  
<https://www.patrimoniotn.it/property/riqualificazione-urbanistica-destra-adige-piedicastello/> (accessed Jul. 21, 2022).
- [13] Municipality of Trento, Mobilità e traffico urbano, PUMS in <https://www.comune.trento.it/Aree-tematiche/Ambiente-e-territorio/Mobilita-e-traffico-urbano/Documentazione/Piano-urbano-della-mobilita-sostenibile-Pums> (accessed Jul. 21, 2022).
- [14] United Nations Environment Programme Global Alliance for Buildings and Construction. "2020 Global Status Report for Buildings and Construction: Towards a Zero-emissions, Efficient and Resilient Buildings and Construction Sector - Executive Summary". 2020.  
[https://globalabc.org/sites/default/files/inline-files/2020%20Buildings%20GSR\\_FULL%20REPORT.pdf](https://globalabc.org/sites/default/files/inline-files/2020%20Buildings%20GSR_FULL%20REPORT.pdf) (accessed Jul. 21, 2022).
- [15] Green Building Council Italia. Gruppo di lavoro Economia Circolare di GBC Italia. "Linee guida per la progettazione circolare di edifici". 2020.  
[https://www.gbccitalia.org/documents/20182/565254/GBC+Italia\\_Linee+Guida+Economia+Circolare.pdf](https://www.gbccitalia.org/documents/20182/565254/GBC+Italia_Linee+Guida+Economia+Circolare.pdf) (accessed Jul. 21, 2022).
- [16] Official website of the Forestry and Fauna Service of the Autonomous Province of Trento  
<https://forestefauna.provincia.tn.it/Foreste/Foreste-in-Trentino> (accessed Oct. 18, 2022).
- [17] Official website of the timber from Trentino. <https://www.legnotrentino.it/it/> (accessed Jul. 21, 2022).

- [18] Official website of the “Renew Wall project”. <https://www.renew-wall.com/> (accessed Jul. 21, 2022).
- [19] Official website of the “Build-in-Wood” project <https://www.build-in-wood.eu/trento> (accessed Jul. 21, 2022).
- [20] HABITECH. “Life-Cycle Assessment background Report for Renew\_Wall FANTI LEGNAMI srl.” 2020.
- [21] Casarin, T., 2021. Examining the effect of government incentives on energy efficiency retrofitting in the Italian real estate market. Ca’ Foscari University of Venice, Venice.
- [22] De Masi, R.F., Festa, V., Gigante, A., Parrotta, M., Ruggiero, S., Russo, A., 2023. Sensitivity analysis about the effectiveness of the energy efficiency measures for residential building under the Italian incentive opportunities, in: 2023 8th International Conference on Smart and Sustainable Technologies (SpliTech). Presented at the 2023 8th International Conference on Smart and Sustainable Technologies (SpliTech), IEEE, Split/Bol, Croatia, pp. 1–4. <https://doi.org/10.23919/SpliTech58164.2023.10193556>
- [23] G. Callegari, E. Merolla, P. Simeone, “Photovoltaic breakthrough in architecture: integration and innovation best practice”, in CONF.ITECH 2022. Technological imagination in the green and digital transition. Conference proceedings, Springer, Switzerland, 2022, ISBN: 978-3-031-29517-1.
- [24] Geothermskin - Energy Wall Modular System in <https://www.knowledge-share.eu/en/patent/geothermskin-energy-wall-modular-system/> (accessed Dec. 4, 2023).
- [235] Encycloenergy. A crowd-open-sourced encyclopedia of energy efficiency enablers for buildings renovation and construction for buildings renovation and construction. (accessed Dec. 4, 2023).
- [26] M. Baralis, M. Barla, “Development and testing of a novel geothermal wall system”, in International Journal of Energy and Environmental Engineering, (2021) 12:689–704, <https://doi.org/10.1007/s40095-021-00407-y> (accessed Dec. 4, 2023).



## GLOSSARY OF TERMS

*Table A.1. Abbreviations used in the report.*

Abbreviation	Description
BAPV	Building Applied Photovoltaics
BEMS	Building Energy Monitoring System
BIPV	Building-Integrated Photovoltaics
CO <sub>2</sub>	Carbon Dioxide
CMV	Controlled Mechanical Ventilation
CPC	Climate Positive Circular Communities
DD	Development Design
DeD	Detailed Design
ECD	Early Concept Design
EPBD	Energy Performance of Buildings Directive
EV	Electric Vehicle
GHG	Greenhouse Gas
H2020	Horizon 2020
HVAC	Heating, Ventilation, and Air Conditioning
IAQ	Indoor Air Quality
ICT	Information and Communication Technologies
IEQ	Indoor Environmental Quality
KPIs	Key Performance Indicators
LCA	Life Cycle Assessment
LCC	Life Cycle Cost
LowEx	Low Exergy
NZC	Net Zero Cities
nZEB	nearly Zero-Energy Building
PED	Positive Energy District
PMTF	Prefabricated Multifunctional Timber-framed Façade
PV	Photovoltaic
RES	Renewable Energy Systems
SDGs	Sustainable Development Goals

V2G	Vehicle-to-Grid
WP	Work Package
ZEN	Zero Emission Neighbourhood

## ACKNOWLEDGEMENTS AND DISCLAIMER

---

The following contributors provided inputs as DTTN Linked Third Parties: Fabio Ferrario and Daniela Casagranda (ARMALAM), Albino Angeli, Donato Fanti (XLAM Dolomiti), Marino Fanti, Gabriele Zini (Fanti Legnami Srl), Nicola Veronesi (Leva Srl).

This project has received funding from the European Union's Horizon 2020 research and innovation programme under grant agreement No 101036723.

This deliverable contains information that reflects only the authors' views, and the European Commission/CINEA is not responsible for any use that may be made of the information it contains.

## PARTNER LOGOS



